

brother®



Computerized
Embroidery and Sewing Machine
Operation Manual

Product Code: 882-W01/W02

Trademarks

FlashFX[®] is a registered trademark of Datalight, Inc.

FlashFX[®] Copyright 1998-2007 Datalight, Inc.

U.S. Patent Office 5,860,082/6,260,156

FlashFX[®] Pro[™] is a trademark of Datalight, Inc.

Datalight[®] is a registered trademark of Datalight, Inc.

Copyright 1989-2007 Datalight, Inc., All Rights Reserved

Video powered by Mobiclip[™] encoding and playback technology. 

“Adobe” and “Adobe Reader” are either registered trademarks or trademarks of Adobe Systems Incorporated in the United States and/or other countries.

IMPORTANT:

READ BEFORE DOWNLOADING, COPYING, INSTALLING OR USING.

By downloading, copying, installing or using the software you agree to this license. If you do not agree to this license, do not download, install, copy or use the software.

Intel License Agreement For Open Source Computer Vision Library

Copyright © 2000, Intel Corporation, all rights reserved. Third party copyrights are property of their respective owners.

Redistribution and use in source and binary forms, with or without modification, are permitted provided that the following conditions are met:

- Redistribution's of source code must retain the above copyright notice, this list of conditions and the following disclaimer.
- Redistribution's in binary form must reproduce the above copyright notice, this list of conditions and the following disclaimer in the documentation and/or other materials provided with the distribution.
- The name of Intel Corporation may not be used to endorse or promote products derived from this software without specific prior written permission.

This software is provided by the copyright holders and contributors “as is” and any express or implied warranties, including, but not limited to, the implied warranties of merchantability and fitness for a particular purpose are disclaimed. In no event shall Intel or contributors be liable for any direct, indirect, incidental, special, exemplary, or consequential damages (including, but not limited to, procurement of substitute goods or services; loss of use, data, or profits; or business interruption) however caused and on any theory of liability, whether in contract, strict liability, or tort (including negligence or otherwise) arising in any way out of the use of this software, even if advised of the possibility of such damage.

All information provided related to future Intel products and plans is preliminary and subject to change at any time, without notice.

INTRODUCTION

Thank you for purchasing this embroidery and sewing machine. Before using this machine, carefully read the “Important Safety Instructions”, and then study this manual for the correct operation of the various functions.

In addition, after you have finished reading this manual, store it where it can quickly be accessed for future reference.

IMPORTANT SAFETY INSTRUCTIONS

**Please read these safety instructions before attempting to use the machine.
This machine is intended for household use.**

DANGER - To reduce the risk of electric shock

- 1** **Always** unplug the machine from the electrical outlet immediately after using, when cleaning, when making any user servicing adjustments mentioned in this manual, or if you are leaving the machine unattended.

WARNING - To reduce the risk of burns, fire, electric shock, or injury to persons.

- 2** **Always** unplug the machine from the electrical outlet when removing covers, lubricating, or when making any adjustments mentioned in the instruction manual.

- To unplug the machine, switch the machine to the symbol “O” position to turn it off, then grasp the plug and pull it out of the electrical outlet. **Do not** pull on the cord.
- Plug the machine directly into the electrical outlet. Do not use an extension cord.
- **Always** unplug your machine if the power is cut.

- 3** **Never** operate this machine if it has a damaged cord or plug, if it is not working properly, if it has been dropped or damaged, or water is spilled on the unit. Return the machine to the nearest authorized dealer or service center for examination, repair, electrical or mechanical adjustment.

- While the machine is stored or in use if you notice anything unusual, such as an odor, heat, discoloration or deformation, stop using the machine immediately and unplug the power cord.
- When transporting the sewing machine, be sure to carry it by its handle. Lifting the sewing machine by any other part may damage the machine or result in the machine falling, which could cause injuries.
- When lifting the sewing machine, be careful not to make any sudden or careless movements, otherwise you may injure your back or knees.

- 4** **Always** keep your work area clear:

- **Never** operate the machine with any air openings blocked. Keep ventilation openings of the sewing machine and foot control free from the build up of lint, dust, and loose cloth.
- **Do not** store objects on the foot controller.
- **Do not** use extension cords. Plug the machine directly into the electrical outlet.
- **Never** drop or insert **any** object into **any** opening.
- **Do not** operate where aerosol (spray) products are being used or where oxygen is being administered.
- **Do not** use the machine near a heat source, such as a stove or iron; otherwise, the machine, power cord or garment being sewn may ignite, resulting in fire or an electric shock.
- **Do not** place this sewing machine on an unstable surface, such as an unsteady or slanted table, otherwise the sewing machine may fall, resulting in injuries.

5 Special care is required when sewing:

- **Always** pay close attention to the needle. Do not use bent or damaged needles.
- Keep fingers away from **all** moving parts. Special care is required around the machine needle.
- Switch the sewing machine to the symbol "O" position to turn it off when making any adjustments in the needle area.
- **Do not** use a damaged or incorrect needle plate, as it could cause the needle to break.
- **Do not** push or pull the fabric when sewing, and follow careful instruction when free motion stitching so that you do not deflect the needle and cause it to break.

6 This machine is **not** a toy:

- Your close attention is necessary when the machine is used by or near children.
- The plastic bag that this sewing machine was supplied in should be kept out of the reach of children or disposed of. Never allow children to play with the bag due to the danger of suffocation.
- Do not use outdoors.

7 For a longer service life:

- When storing this machine, avoid direct sunlight and high humidity locations. Do not use or store the machine near a space heater, iron, halogen lamp, or other hot objects.
- Use only neutral soaps or detergents to clean the case. Benzene, thinner, and scouring powders can damage the case and machine, and should never be used.
- Always consult the operation manual when replacing or installing any assemblies, the presser feet, needle, or other parts to assure correct installation.

8 For repair or adjustment:

- If the light unit is damaged, it must be replaced by an authorized dealer.
- In the event a malfunction occurs or adjustment is required, first follow the troubleshooting table in the back of the operation manual to inspect and adjust the machine yourself. If the problem persists, please consult your local authorized Brother dealer.

Use this machine only for its intended use as described in the manual.

Use accessories recommended by the manufacturer as contained in this manual.

Use only the interface cable (USB cable) included with this machine.

Use only the USB mouse included with this machine.

The contents of this manual and specifications of this product are subject to change without notice.

For additional product information and updates, visit our website at www.brother.com

SAVE THESE INSTRUCTIONS

FOR USERS IN THE UK, EIRE, MALTA AND CYPRUS ONLY

IMPORTANT

- In the event of replacing the plug fuse, use a fuse approved by ASTA to BS 1362, i.e. carrying the  mark, rating as marked on plug.
- Always replace the fuse cover. Never use plugs with the fuse cover omitted.
- If the available electrical outlet is not suitable for the plug supplied with this equipment, you should contact your authorized dealer to obtain the correct lead.

FOR USERS IN AC INPUT 220-240V COUNTRIES

This appliance is not intended for use by persons (including children) with reduced physical, sensory or mental capabilities, or lack of experience and knowledge, unless they have been given supervision or instruction concerning use of the appliance by a person responsible for their safety. Children should be supervised to ensure that they do not play with the appliance.

Federal Communications Commission (FCC) Declaration of Conformity (For USA Only)

Responsible Party: Brother International Corporation
100 Somerset Corporate Boulevard
Bridgewater, NJ 08807-0911 USA
TEL : (908) 704-1700

declares that the product

Product Name: Brother Sewing Machine
Model Number: NV6000D

This device complies with Part 15 of the FCC Rules. Operation is subject to the following two conditions: (1) this device may not cause harmful interference, and (2) this device must accept any interference received, including interference that may cause undesired operation.

This equipment has been tested and found to comply with the limits for a Class B digital device, pursuant to Part 15 of the FCC Rules. These limits are designed to provide reasonable protection against harmful interference in a residential installation. This equipment generates, uses, and can radiate radio frequency energy and, if not installed and used in accordance with the instructions, may cause harmful interference to radio communications. However, there is no guarantee that interference will not occur in a particular installation. If this equipment does cause harmful interference to radio or television reception, which can be determined by turning the equipment off and on, the user is encouraged to try to correct the interference by one or more of the following measures:

- Reorient or relocate the receiving antenna.
- Increase the separation between the equipment and receiver.
- Connect the equipment into an outlet on a circuit different from that to which the receiver is connected.
- Consult the dealer or an experienced radio/TV technician for help.
- The included interface cable should be used in order to ensure compliance with the limits for a Class B digital device.
- Changes or modifications not expressly approved by Brother Industries, Ltd. could void the user's authority to operate the equipment.

WARNING LABEL

The following warning label is on the included side cutter. Be sure to observe the precaution.



⚠ CAUTION

- When using the side cutter, sew between low and mid-speed and do not touch the knives or operation lever of the side cutter while sewing to avoid equipment damage or injury.

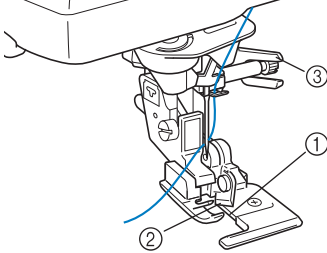

① Guide plate (lower knife)

② Upper knife

③ Operation lever

Label location

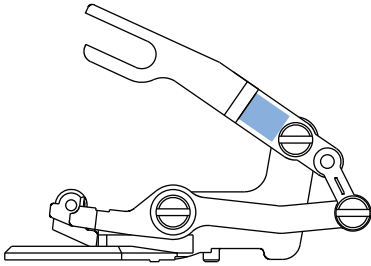

OUTSTANDING FEATURES

Checking the Needle Location in the Screen

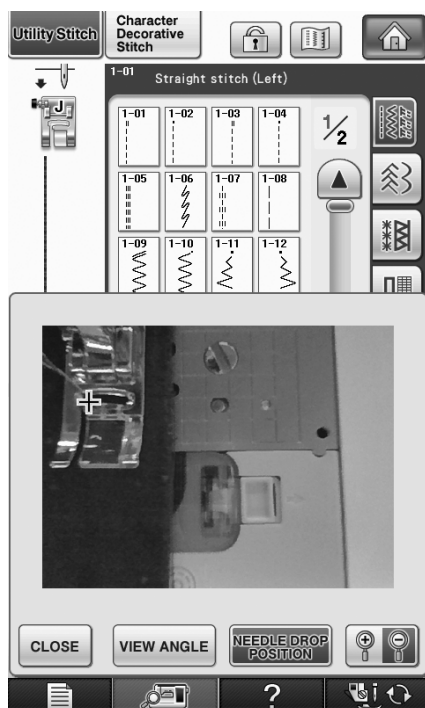

You can check the needle drop position on the screen of your machine, even if the needle has not actually been lowered. Also, you can view the location of the needle within the sewing area in the screen.

See “Checking the Needle Location in the Screen” on page 75.

Edge Sewing

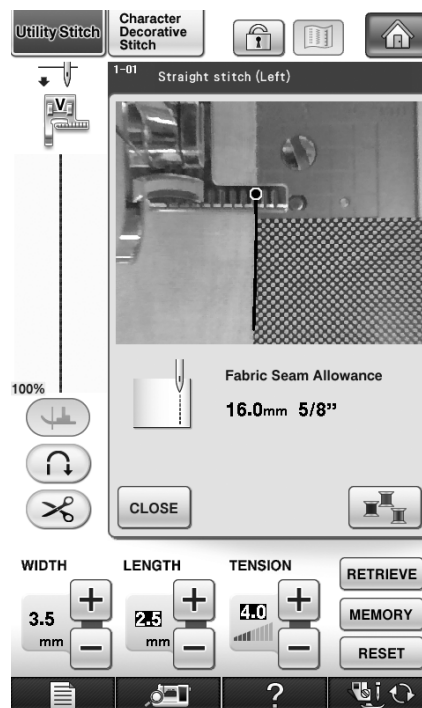

Using the built-in camera, the width of the area from the edge of the fabric to the stitching line can be measured and set for edge sewing. See “Edge Sewing” on page 138.

Using the Built-In Camera to Align the Embroidering Position

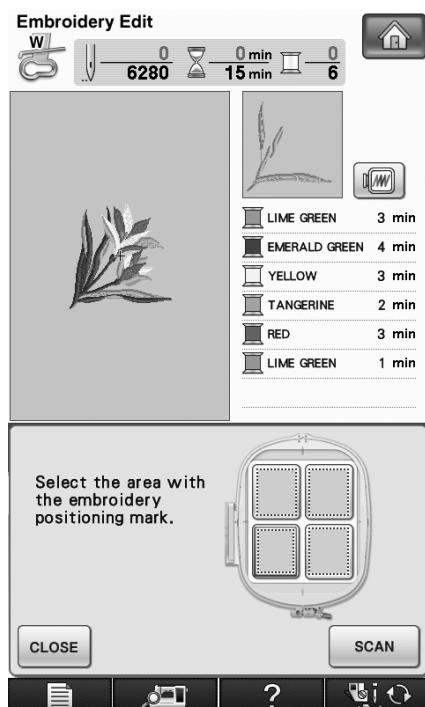

The embroidering position can easily be aligned by using the machine's built-in camera and the enclosed embroidery positioning sticker. See "Using the Built-In Camera to Align the Embroidering Position" on page 206 and 302.

Uninterrupted Embroidering (Using a Single Color)

You can embroider a multi-color pattern with a single color without stopping the machine while embroidering.

See "Uninterrupted Embroidering (Using a Single Color)" on page 295.

Duplicating a Pattern

You can duplicate a desired pattern with one touch. See "Duplicating a Pattern" on page 290.

Print and Stitch (Combining the Embroidery and Printing)

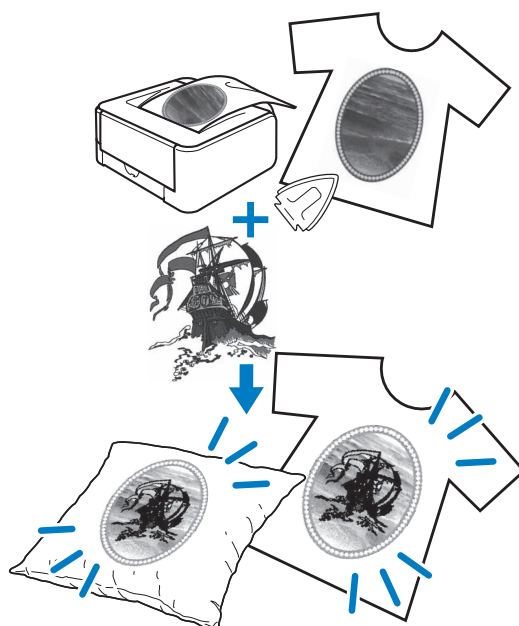

Completed embroidery patterns can be combined with printed backgrounds that are built into this machine.

Beautiful three-dimensional embroidered designs can be created by ironing a background onto fabric or printing it onto printable fabric, and then embroider a design to compliment the background.

See "PRINT AND STITCH (COMBINING EMBROIDERY PATTERNS AND PRINTED DESIGNS)" on page 217 and 306.



Note

- Print the background and embroidery position sheet in their original dimensions. If an image is printed in a different size, the sizes of the embroidery pattern and background may not match. In addition, the built-in camera cannot detect the embroidery position mark. Make sure that the print settings are correctly specified.

WHAT YOU CAN DO WITH THIS MACHINE

Getting Ready

To learn the operation of the principal parts and the screens

Chapter 1
Page 11

Sewing Basics

To learn how to prepare for sewing and basic sewing operations

Chapter 2
Page 59

Utility Stitches

Pre-programmed with more than 100 frequently used stitches

Chapter 3
Page 77

Character/Decorative Stitches

The variety of stitches widen your creativity

Chapter 4
Page 145

Embroidery

Maximum 30 cm x 20 cm (approx. 12 x 8 inches) for large embroidery designs

Chapter 5
Page 181

Embroidery Edit

Designs can be combined, rotated or enlarged

Chapter 6
Page 261

My Custom Stitch

Create original decorative stitches

Chapter 7
Page 313

Appendix

Caring for your machine and dealing with errors and malfunctions

Chapter 8
Page 325

HOW TO USE THIS MANUAL

Chapter 1 and Chapter 2 explain your sewing machine's basic operation procedures for someone who is using the sewing machine for the first time. If you want to sew utility stitches or character/ decorative stitches, read Chapter 1 and Chapter 2, then go on to Chapter 3 (Utility Stitches) or Chapter 4 (Character/ Decorative Stitches).

When you are ready to begin using the embroidery function after reading Chapter 1 and Chapter 2, proceed to Chapter 5 (Embroidery). Once you understand the steps explained in Chapter 5, go on to Chapter 6 (Embroidery Edit) for an explanation about the embroidery edit functions.

In the screens appearing in the step-by-step instructions, the parts referred to in the operations are marked with . Compare the screen in the directions with the actual screen, and carry out the operation.

If, while using the machine, you experience something you do not understand, or there is a function you would like to know more about, refer to the index at the back of the operation manual in conjunction with the table of contents to find the section of the manual you should refer to.

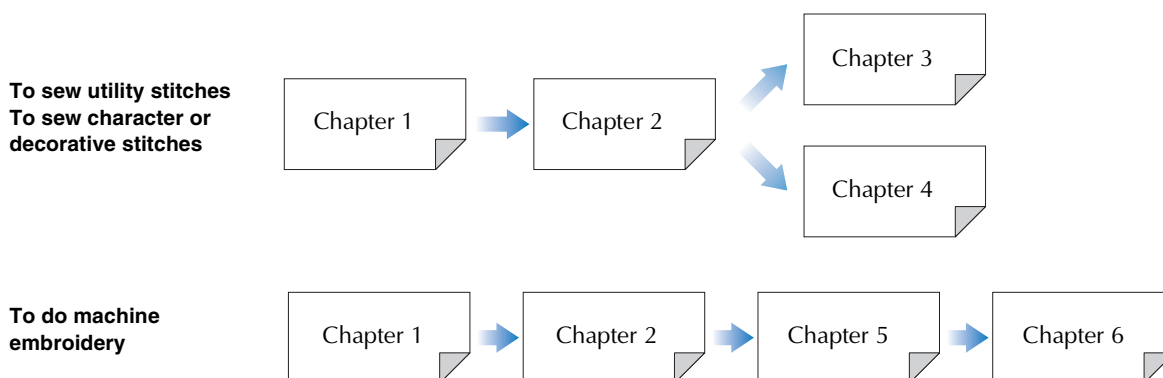

CONTENTS

INTRODUCTION	i
IMPORTANT SAFETY INSTRUCTIONS	i
OUTSTANDING FEATURES	vi
WHAT YOU CAN DO WITH THIS MACHINE	viii
HOW TO USE THIS MANUAL	ix
NAMES OF MACHINE PARTS AND THEIR FUNCTIONS	1
Machine	1
Needle and Presser Foot Section	2
Embroidery Unit	3
Operation Buttons	3
Using the Flat Bed Attachment	4
Using the Accessory Case	4
Storing Bobbin Clips	5
Using the Embroidery Unit Carrying Case	5
Included Accessories	5
Options	8
Using the Spool Stand	9
Chapter 1 Getting Ready	11
TURNING THE MACHINE ON/OFF	12
LCD SCREEN	14
USB Connectivity	18
Using the Machine Setting Mode Key	22
Using the Sewing Machine Help Key	32
Using the Operation Guide Function	33
Using the Sewing Guide Function	34
Using the Pattern Explanation Function	35
LOWER THREADING	37
Winding the Bobbin	37
Setting the Bobbin	43
Pulling Up the Bobbin Thread	45
UPPER THREADING	46
Upper Threading	46
Using the Twin Needle Mode	49
Using the Spool Stand	52
Using Threads that Unwind Quickly	53
CHANGING THE PRESSER FOOT	54
Removing the Presser Foot	54
Attaching the Presser Foot	54
Attaching the Walking Foot	55
CHANGING THE NEEDLE	56
About the Needle	58
Fabric/Thread/Needle Combinations	58
Chapter 2 Sewing Basics	59
SEWING	60
Sewing a Stitch	60
Sewing Reinforcement Stitches	62
Sewing Curves	62
Changing Sewing Direction	63
Sewing Heavyweight Fabrics	63
Sewing Hook-and-Loop Fastener	64
Sewing Lightweight Fabrics	64
Sewing Stretch Fabrics	65
STITCH SETTINGS	66
Setting the Stitch Width	66
Setting the Stitch Length	67
Setting the Thread Tension	67
USEFUL FUNCTIONS	69
Automatic Reinforcement Stitching	69
Automatic Thread Cutting	70
Using the Knee Lifter	71
Pivoting	72
Automatic Fabric Sensor System (Automatic Presser Foot Pressure)	73
Needle Position – Stitch Placement	74
Locking the Screen	74
Checking the Needle Location in the Screen	75
Chapter 3 Utility Stitches	77
SELECTING UTILITY STITCHES	78
Selecting a Stitch	79
Saving Your Stitch Settings	81
SEWING THE STITCHES	83
Straight Stitches	83
Dart Seam	88
Gathering	88
Flat Fell Seam	89
Pintuck	90
Zigzag Stitches	91
Elastic Zigzag Stitches	93
Overcasting	94
Quilting	99
Blind Hem Stitches	111
Appliqué	113
Shelltuck Stitches	114
Scallop Stitches	115
Crazy Quilting	116
Smocking Stitches	116
Fagoting	117
Tape or Elastic Attaching	117
Heirloom	119
One-step Buttonholes	121
Four-step Buttonholes	125
Bar Tacks	129
Button Sewing	131
Eyelet	133
Multi-directional Sewing (Straight Stitch and Zigzag Stitch)	134
Zipper Insertion	135
Edge Sewing	138
Chapter 4 Character/Decorative Stitches	145
SELECTING STITCH PATTERNS	146
Selecting Decorative Stitch Patterns/7mm Decorative Stitch Patterns/Satin Stitch Patterns/7mm Satin Stitch Patterns/Cross Stitch/Utility Decorative Stitch Patterns	148
Alphabet Characters	148
SEWING STITCH PATTERNS	152
Sewing Attractive Finishes	152
Basic Sewing	152
Making Adjustments	153
EDITING STITCH PATTERNS	155
Changing the Size	157
Changing the Length (for 7mm Satin Stitch Patterns Only)	157
Creating a Vertical Mirror Image	157
Creating a Horizontal Mirror Image	158
Sewing a Pattern Continuously	158
Changing Thread Density (for Satin Stitch Patterns Only)	158
Returning to the Beginning of the Pattern	159
Checking the Image	160
COMBINING STITCH PATTERNS	162
Before Combining	162
Combining Various Stitch Patterns	162
Combining Large and Small Stitch Patterns	164
Combining Horizontal Mirror Image Stitch Patterns	165
Combining Stitch Patterns of Different Length	165
Making Step Stitch Patterns (for 7mm Satin Stitch Patterns Only)	166
USING THE MEMORY FUNCTION	169
Stitch Data Precautions	169
Saving Stitch Patterns in the Machine's Memory	171
Saving Stitch Patterns to USB Media	174
Saving Stitch Patterns in the Computer	175
Retrieving Stitch Patterns from the Machine's Memory	176

Recalling from USB Media	177	EMBROIDERY APPLICATIONS	256
Recalling from the Computer	179	Using a Frame Pattern to Make an Appliqué (1).....	256
Chapter 5 Embroidery	181	Using a Frame Pattern to Make an Appliqué (2).....	257
BEFORE EMBROIDERING	182	Sewing Split Embroidery Patterns	259
Embroidery Step by Step	182	Chapter 6 Embroidery Edit	261
Attaching Embroidery Foot “W”	183	EXPLANATION OF FUNCTIONS.....	262
Attaching the Embroidery Unit.....	184	SELECTING PATTERNS TO EDIT	263
SELECTING PATTERNS.....	186	Selecting Embroidery Patterns/Brother “Exclusives”/Greek	
Selecting Embroidery Patterns/Brother “Exclusives”/Greek		Alphabet Patterns/Floral Alphabet Patterns/Utility Embroidery	
Alphabet Patterns/Floral Alphabet Patterns/Utility Embroidery		Patterns/Frame Patterns	264
Patterns	189	Selecting Alphabet Character Patterns	264
Selecting Alphabet Character Patterns	190	EDITING PATTERNS.....	267
Selecting Frame Patterns	192	Moving the Pattern	269
Selecting Patterns from Embroidery Cards	194	Rotating the Pattern	269
Selecting Patterns from USB Media/Computer.....	195	Changing the Size of the Pattern.....	270
VIEWING THE SEWING SCREEN.....	196	Deleting the Pattern.....	271
PREPARING THE FABRIC	198	Changing the Configuration of Alphabet Character Patterns	271
Attaching Iron-on Stabilizers (Backing) to the Fabric	198	Changing Alphabet Character Spacing	272
Hooping the Fabric in the Embroidery Frame.....	200	Reducing Character Spacing.....	273
Embroidering Small Fabrics or Fabric Edges	203	Separating Combined Character Patterns.....	274
ATTACHING THE EMBROIDERY FRAME.....	204	Changing the Color of Each Alphabet Character in a Pattern	275
CONFIRMING THE PATTERN POSITION.....	206	Embroidering Linked Characters.....	276
Using the Built-In Camera to Align the Embroidering Position.....	206	Changing the Thread Color	278
Checking the Pattern Position	209	Creating a Custom Thread Table	279
Previewing the Completed Pattern	210	Choosing a Color from the Custom Thread Table	283
SEWING AN EMBROIDERY PATTERN	212	Designing Repeated Patterns	284
Sewing Attractive Finishes.....	212	Duplicating a Pattern.....	290
Sewing Embroidery Patterns	213	After Editing	290
Sewing Embroidery Patterns Which Use Appliqué	215	COMBINING PATTERNS.....	291
PRINT AND STITCH (COMBINING EMBROIDERY		Editing Combined Patterns	291
PATTERNS AND PRINTED DESIGNS)	217	Sewing Combined Patterns.....	294
Selecting a Pattern	218	VARIOUS EMBROIDERING FUNCTIONS.....	295
Outputting the Background Image and Positioning Image.....	219	Uninterrupted Embroidering (Using a Single Color)	295
Printing the Background and Embroidery Position Sheet	221	Basting Embroidery	295
Sewing Embroidery Patterns	222	Creating an Appliqué Piece	296
ADJUSTMENTS DURING THE EMBROIDERY		Using the Built-In Camera to Align the Embroidering Position	302
PROCESS	223	USING THE MEMORY FUNCTION	305
If the Bobbin Runs Out of Thread.....	223	PRINT AND STITCH (COMBINING EMBROIDERY	
If the Thread Breaks During Sewing	224	PATTERNS AND PRINTED DESIGNS)	306
Restarting from the Beginning	225	Selecting a Pattern.....	307
Resuming Embroidery After Turning Off the Power	225	Outputting the Background Image and Positioning Image	308
MAKING EMBROIDERY ADJUSTMENTS	227	Printing the Background and Embroidery Position Sheet.....	310
Adjusting Thread Tension	227	Sewing Embroidery Patterns	310
Adjusting the Alternate Bobbin Case		Chapter 7 MY CUSTOM STITCH	313
(with No Color on the Screw).....	228	DESIGNING A STITCH	314
Using the Automatic Thread Cutting Function		ENTERING STITCH DATA	316
(END COLOR TRIM)	229	USING STORED CUSTOM STITCHES.....	322
Using the Thread Trimming Function (JUMP STITCH TRIM).....	230	Storing Custom Stitches in Your List	322
Adjusting the Embroidery Speed	231	Retrieving Stored Stitches	323
Changing the Thread Color Display	231	Chapter 8 Appendix	325
Changing the Embroidery Frame Display	232	CARE AND MAINTENANCE	326
REVISING THE PATTERN	234	Cleaning the LCD Screen	326
Changing the Pattern Position	234	Cleaning the Machine Casing.....	326
Aligning the Pattern and the Needle.....	235	Cleaning the Race	326
Changing the Size	236	Cleaning the Cutter in the Bobbin Case Area.....	327
Rotating the Pattern.....	237	About the Maintenance Message.....	328
Creating a Horizontal Mirror Image	238	ADJUSTING THE SCREEN	329
Changing the Density		Touch Panel is Malfunctioning	329
(Alphabet Character and Frame Patterns Only).....	239	TROUBLESHOOTING	330
Changing the Colors of Alphabet Character Patterns	240	ERROR MESSAGES.....	335
Embroidering Linked Characters	241	SPECIFICATIONS.....	343
Uninterrupted Embroidering (Using a Single Color).....	243	UPGRADING YOUR MACHINE’S SOFTWARE.....	344
USING THE MEMORY FUNCTION.....	244	Upgrade Procedure Using USB Media.....	344
Embroidery Data Precautions	244	Upgrade Procedure Using Computer	345
Saving Embroidery Patterns in the Machine’s Memory	246	STITCH SETTING CHART	347
Saving Embroidery Patterns to USB Media	249	INDEX.....	356
Saving Embroidery Patterns in the Computer.....	250		
Retrieving Patterns from the Machine’s Memory	251		
Recalling from USB Media.....	252		
Recalling from the Computer	254		

1

2

3

4

5

6

7

8

NAMES OF MACHINE PARTS AND THEIR FUNCTIONS

The names of the various parts of the sewing machine and their functions are described below. Before using the sewing machine, carefully read these descriptions to learn the names of the machine parts.

Machine

■ Front View

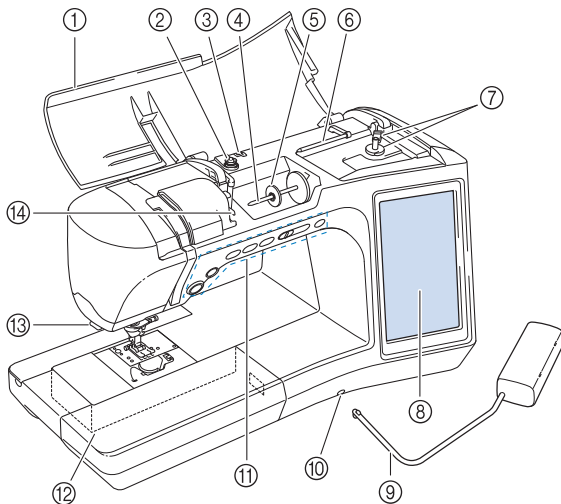

- ① **Top cover**
Open the top cover to thread the machine and wind the bobbin.
- ② **Pre-tension disk**
Pass the thread around the pre-tension disk when winding the bobbin thread. (page 37)
- ③ **Thread guide for bobbin winding**
Pass the thread through this thread guide when winding the bobbin thread. (page 37)
- ④ **Spool pin**
Place a spool of thread on the spool pin. (page 46)
- ⑤ **Spool cap**
Use the spool cap to hold the spool of thread in place. (page 46)
- ⑥ **Supplemental spool pin**
Use this spool pin to wind the bobbin thread, or to sew with the twin needle. (page 37, 49)
- ⑦ **Bobbin winder**
Use the bobbin winder when winding the bobbin. (page 37)
- ⑧ **LCD (liquid crystal display)**
Settings for the selected stitch and error messages appear in the LCD. (page 14)
- ⑨ **Knee lifter**
Use the knee lifter to raise and lower the presser foot. (page 71)
- ⑩ **Knee lifter slot**
Insert the knee lifter into the slot. (page 71)
- ⑪ **Operation buttons (6 buttons) and sewing speed controller**
Use these buttons and the slide to operate the sewing machine. (page 3)
- ⑫ **Flat bed attachment with accessory compartment**
Store presser feet and bobbins in the accessory compartment of the flat bed attachment. When sewing cylindrical pieces, remove the flat bed attachment. (page 4)
- ⑬ **Thread cutter**
Pass the threads through the thread cutter to cut them. (page 48)
- ⑭ **Thread guide plate**
Pass the thread around the thread guide plate when threading upper thread. (page 46)

■ Right-side/Rear View

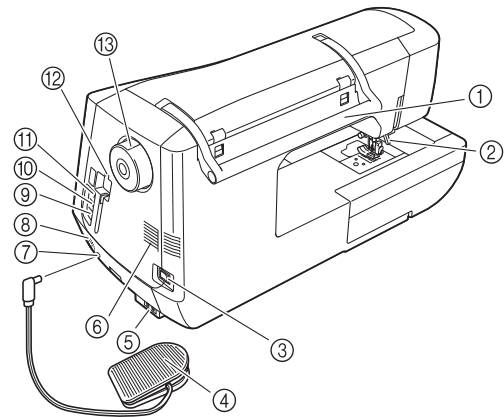

- ① **Handle**
Carry the sewing machine by its handle when transporting the machine.
- ② **Presser foot lever**
Raise and lower the presser foot lever to raise and lower the presser foot. (page 54)
- ③ **Main power switch**
Use the main power switch to turn the sewing machine ON and OFF. (page 12)
- ④ **Foot controller with retractable cord**
Depress the foot controller to control the speed of the machine. (page 61)
- ⑤ **Power cord receptacle**
Insert the power cord into the machine receptacle. (page 12)
- ⑥ **Air vent**
The air vent allows the air surrounding the motor to circulate. Do not cover the air vent while the sewing machine is being used.
- ⑦ **Foot controller jack**
Insert the foot controller plug into its jack on the machine. (page 61)
- ⑧ **Speaker**
- ⑨ **USB port for computer**
In order to import/export patterns between a computer and the machine, plug the USB cable into the USB port. (page 18, 175, 250)
- ⑩ **USB port for mouse (page 18)**
- ⑪ **Primary (top) USB port for media**
In order to send patterns from/to USB media, plug the USB media directly into the USB port. (page 18, 174, 249)
- ⑫ **Touch pen holder**
Use the touch pen holder to hold the touch pen when not in use.
- ⑬ **Handwheel**
Rotate the handwheel toward you (counterclockwise) to raise and lower the needle. The wheel should be turned toward the front of the machine.

Needle and Presser Foot Section

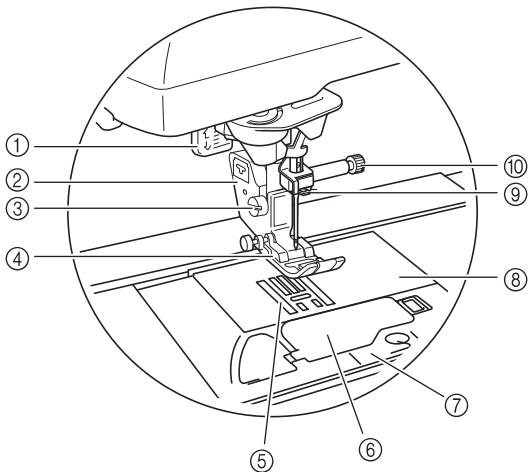

- ① **Buttonhole lever**
The buttonhole lever is used with the one-step buttonhole foot to create buttonholes. (page 121)
- ② **Presser foot holder**
The presser foot is attached to the presser foot holder. (page 54)
- ③ **Presser foot holder screw**
Use the presser foot holder screw to hold the presser foot in place. (page 55)
- ④ **Presser foot**
The presser foot consistently applies pressure to the fabric as sewing takes place. Attach the appropriate presser foot for the selected stitch. (page 54)
- ⑤ **Feed dogs**
The feed dogs feed the fabric in the sewing direction.
- ⑥ **Bobbin cover**
Open the bobbin holder to set the bobbin. (page 43, 92)
- ⑦ **Needle plate cover**
Remove the needle plate cover to clean the race. (page 86, 213)
- ⑧ **Needle plate**
The needle plate is marked with guides to help sew straight seams. (page 85)
- ⑨ **Needle bar thread guide**
Pass the upper thread through the needle bar thread guide. (page 46)
- ⑩ **Needle clamp screw**
Use the needle clamp screw to hold the needle in place. (page 55)

Measurements on the needle plate, bobbin cover (with mark) and needle plate cover

The measurements on the bobbin cover are references for patterns with a middle (center) needle position. The measurements on the needle plate and the needle plate cover are references for stitches with a left needle position.

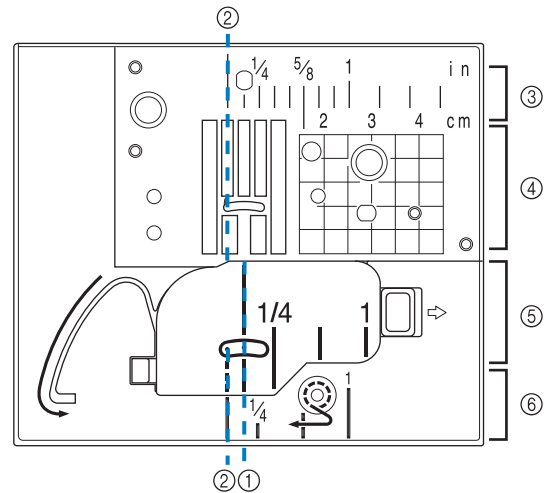

- ① **For stitches with a middle (center) needle position**
- ② **For stitches with a left needle position**
- ③ **Left needle position on the needle plate <inch>**
- ④ **Left needle position on the needle plate <cm>**
- ⑤ **Middle (center) needle position on the bobbin cover (with mark) <inch>**
- ⑥ **Left needle position on the needle plate cover <inch>**

Embroidery Unit

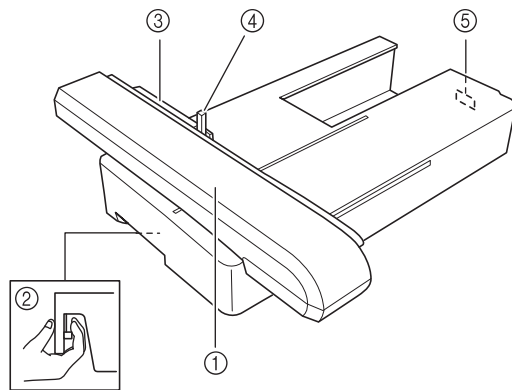

- ① **Carriage**
The carriage moves the embroidery frame automatically when embroidering. (page 184)
- ② **Release button (located under the embroidery unit)**
Press the release button to remove the embroidery unit. (page 185)
- ③ **Embroidery frame holder**
Insert the embroidery frame into the embroidery frame holder to hold the frame in place. (page 204)
- ④ **Frame-securing lever**
Press the frame-securing lever down to secure the embroidery frame. (page 204)
- ⑤ **Embroidery unit connection**
Insert the embroidery unit connection into the connection port when attaching the embroidery unit. (page 184)

⚠ CAUTION

- After the embroidery frame is set in the frame holder, be sure the frame-securing lever is correctly lowered.

Operation Buttons

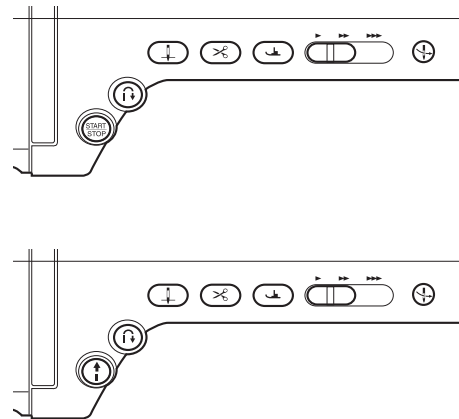

- ① **“Start/Stop” button**
Press this button and the machine will sew a few stitches at a slow speed and then begin sewing at the speed set by the sewing speed controller. Press the button again to stop the machine. Hold the button in to sew at the machine's slowest speed. The button changes color according to the machine's operation mode.

Green: The machine is ready to sew or is sewing.
Red: The machine cannot sew.
- ② **“Reverse/Reinforcement Stitch” button**
Use this button to sew reinforcement stitches at the beginning and end of sewing. Press this button, and the machine sews 3 stitches in the same spot and stops automatically. For straight and zigzag stitch patterns that take reverse stitches, the machine will sew reverse stitches at low speed only while holding down the “Reverse/Reinforcement Stitch” button (the stitches are sewn in the opposite direction).
- ③ **“Needle Position” button**
Use this button when changing sewing direction or for detailed sewing in small areas. Press this button to raise or lower the needle position. With this button, you can lower and raise the needle to sew a single stitch.
- ④ **“Thread Cutter” button**
Press this button after sewing to automatically trim the excess thread.
- ⑤ **“Presser Foot Lifter” button**
Press this button to lower the presser foot and apply pressure to the fabric. Press this button again to raise the presser foot.
- ⑥ **Sewing Speed controller**
Use this controller to adjust the sewing speed. Move the slide to the left to sew at slower speeds. Move the slide to the right to sew at higher speeds. Beginners should sew at a slow speed.
- ⑦ **“Automatic Threading” button**
Use this button to automatically thread the needle.

⚠ CAUTION

- Do not press the thread cutter button after the threads have been cut. The needle may break and threads may become tangled, or damage to the machine may occur.

Using the Flat Bed Attachment

Pull the top of the flat bed attachment to open the accessory compartment.

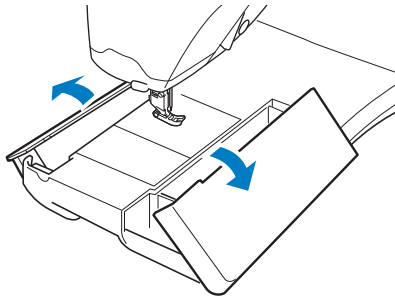

Using the Accessory Case

Opening the Accessory Case

Fully slide the bar on each side of the accessory case, and then lift off the lid to open the case. The case can only be opened or locked correctly if both bars are slid in the same direction.

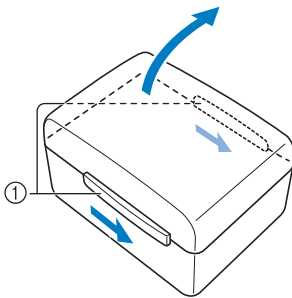

① Bars

Closing the Accessory Case

1 Fully slide the bar on each side of the accessory case lid to align the notches in the lid with the notches in the bars.

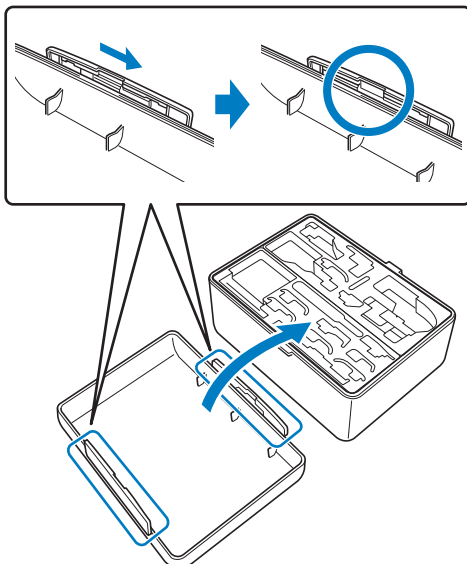

2 Place the lid on top of the case so that the notches in the lid align with the tabs on the case, and then slide the bar on each side back to the center of the accessory case.

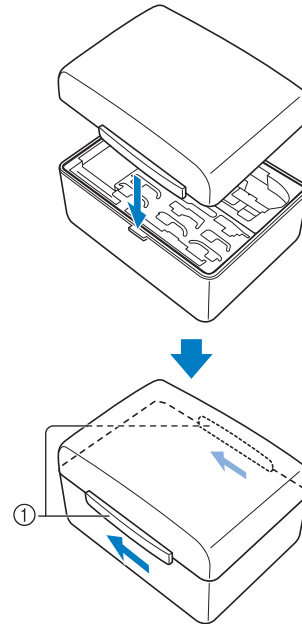

① Bars

Using the Accessory Trays

Two presser foot storage trays are stored in the included accessory case. One is for presser feet for utility sewing, and the other is for presser feet for embroidery and machine quilting.

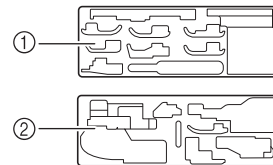

① For presser feet for utility sewing

② For presser feet for embroidery and machine quilting

For your convenience, a presser foot storage tray can be stored in the accessory compartment of the flat bed attachment.

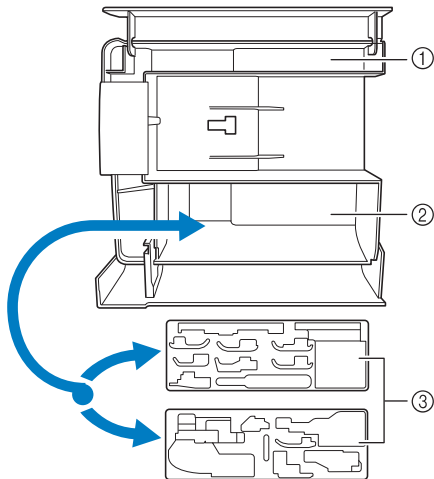

- ① Storage space of the flat bed attachment
- ② Presser foot storage space of the flat bed attachment
- ③ Presser foot storage trays

Storing Bobbin Clips

Bobbin clips can be stored inside of the accessory case cover.

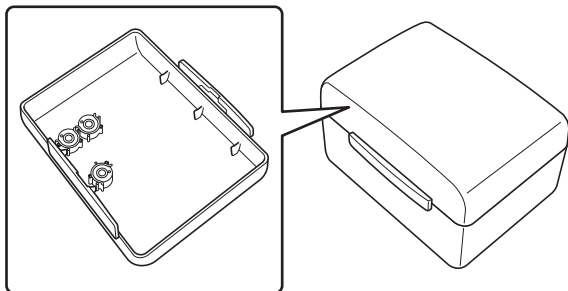

Memo

- Placing bobbin clips on bobbins helps prevent the thread from unwinding from the bobbin. In addition, snapping bobbin clips together allows the bobbins to be conveniently stored and prevents them from rolling around if they are dropped.

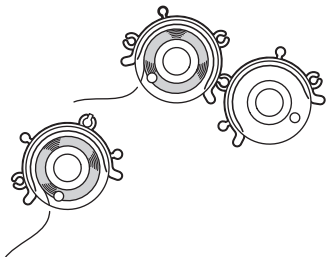

Using the Embroidery Unit Carrying Case

Included accessories 43-46 are contained in the embroidery unit carrying case. To open the embroidery unit carrying case, raise each lock and move the latches out of position. To re-hook the latches and securely close the case, position the latch on the catch of the unit lid and lower the lock till it snaps.

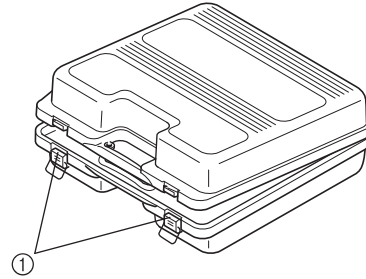

- ① Latches

Included Accessories

See table on the next page about included accessories.

1	2	3	4	5	6	7	
8	9	10	11	12	13	14	
16	17	18	19	20	21	22	
<p>75/11 2 needles 90/14 2 needles 90/14 2 needles: Ball point needle (gold colored)</p>	<p>2.0/11 needle</p>	<p>75/11 2 needles</p>					
23	24	25	26	27	28	29	
30	31	32	33	34	35	36	
37	38	39	40	41	42	43*	44*
45*	46*	47	48	49	50	51	52

*Included Accessories 43-46 are contained in the embroidery unit carrying case.

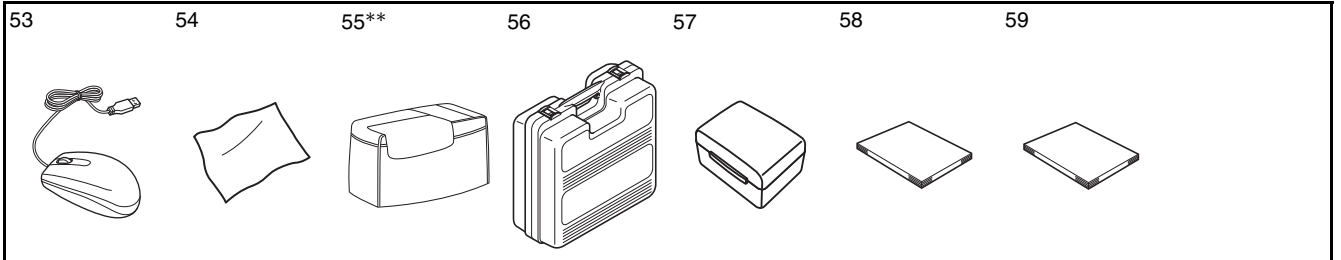

**In some countries or regions, this is not included in the enclosed accessories; however, it is available as an option.

No.	Part Name	Part Code	
		U.S.A./ Canada	Others
1	Zigzag foot "J" (on machine)		XC3021-051
2	Monogramming foot "N"		X53840-351
3	Overcasting foot "G"		XC3098-051
4	Zipper foot "I"		X59370-051
5	Buttonhole foot "A"		X57789-151
6	Blind stitch foot "R"		X56409-051
7	Button fitting foot "M"		130489-001
8	Walking foot	SA140	F033N: XC2214-002
9	Side cutter foot	SA177	F054: XC3879-002
10	Straight stitch foot	SA167	F042N: XC1973-052
11	Free motion quilting foot "C"		XE0765-101
12	Free motion echo quilting foot "E"		XE0766-001
13	Free motion open toe quilting foot "O"	SA187	F061: XE1097-001
14	Embroidery foot "W"		XC8156-651
15	Vertical stitch alignment foot "V"	SA189	F063: XE5224-001
16	Needle set		XE4962-001
17	Twin needle		XE4963-001
18	Ball point needle set		XD0705-051
19	Bobbin x 10 (One is on machine.)	SA156	SFB: XA5539-151
20	Seam ripper		X54243-051
21	Scissors		XC1807-121
22	Cleaning brush		X59476-051
23	Eyelet punch		135793-001
24	Screwdriver (small)		X55468-051
25	Screwdriver (large)		XC4237-021
26	Disc-shaped screwdriver		XC1074-051
27	Spool cap (small)		130013-154
28	Spool cap (medium) x 2 (One is on machine.)		X55260-153
29	Spool cap (large)		130012-054
30	Spool stand		See page 9
31	Bobbin clip x 10		XE3060-001
32	Spool felt		X57045-051
33	Spool net x 2		XA5523-050
34	Embroidery needle plate cover		XE4708-001
35	Touch pen (stylus)		XA9940-051
36	Knee lifter	SA599	KL1: XE5902-001
37	USB cable		XD0745-051
38	Alternate bobbin case (no color)		XC8167-451
39	Straight stitch needle plate	SA550	SNP01: XD0606-152
40	Cord guide bobbin cover (with single hole)		XC8449-051
41	Bobbin cover (with mark)		XE0756-001
42	Foot controller		XD0500-051 (EU area) XC8028-051 (other area)

No.	Part Name	Part Code	
		U.S.A./ Canada	Others
43	Embroidery frame set (small) H 2 cm x W 6 cm (H 1 inch x W 2-1/2 inches)	SA437	EF73: XC8479-052
44	Embroidery frame set (medium) H 10 cm x W 10 cm (H 4 inches x W 4 inches)	SA438	EF74: XC8480-052
45	Embroidery frame set (quilt) H 20 cm x W 20 cm (H 8 inches x W 8 inches)	SA446	EF91: XE5068-001
46	Embroidery frame set (extra large) H 30 cm x W 20 cm (H 12 inches x W 8 inches)	SA477	EF92: XE5071-001
47	Embroidery bobbin thread	SA-EBT	XC6283-001
48	Embroidery positioning stickers x 3		XE4912-101
49	Edge sewing sheet x 6		XE5500-001
50	Stabilizer material	SA519	BM3: XE0806-001
51	Grid sheet set	SA507	GS3: X81277-151
52	Chalk pencil		184944-001
53	USB mouse		XE5334-001
54	LCD cleaning cloth		XE4913-001
55	Soft cover		XE5111-001 (882-W01) XE5163-001 (882-W02)
56	Embroidery unit carrying case		XE3791-001
57	Accessory case		XE4909-001
58	Operation manual		This manual
59	Quick reference guide		XE4917-001

Memo

- Foot controller: Model S
This foot controller can be used on the machine with product code 882-W01/W02. The product code is mentioned on the machine rating plate.

Memo

- Always use accessories recommended for this machine.
- The screw for the presser foot holder is available through your authorized dealer (Part code XA4813-051).
- Included accessories 37, 42, 58 and 59 can be stored in the machine's soft cover case. (In some countries or regions, the soft cover case is not included in the enclosed accessories; however, it is available as an option.)

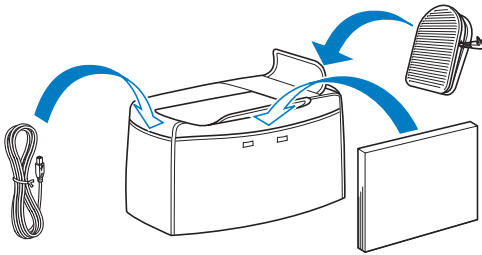

Options

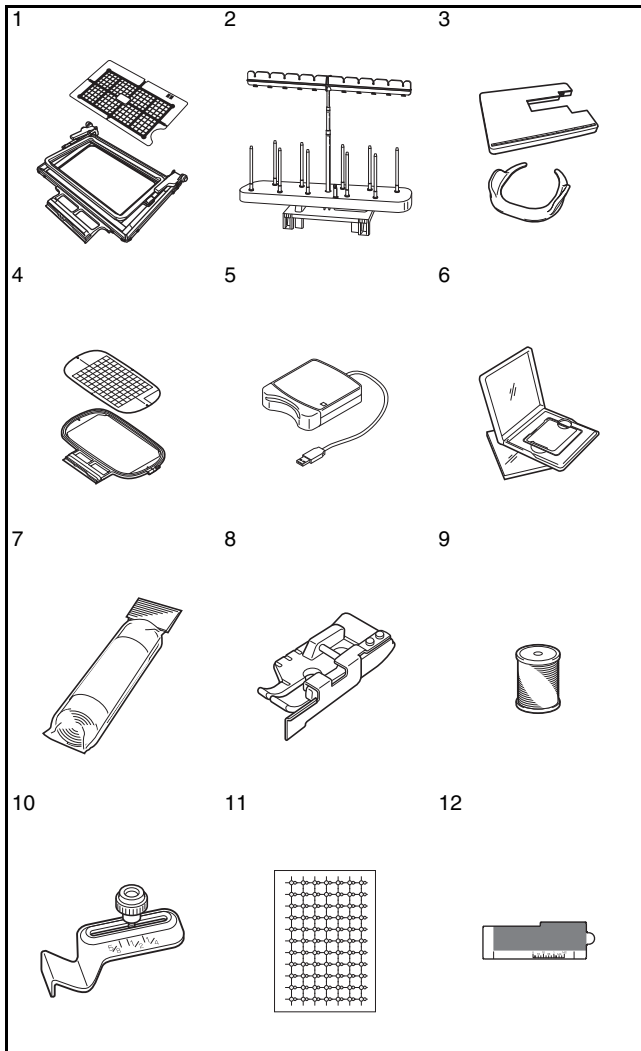

No.	Part Name	Part Code	
		U.S.A./Canada	Others
1	Border embroidery frame set H 18 cm x W 10 cm (H 7 inches x W 4 inches)	SABF6000D	BF2: XE5059-001
2	10 spool stand	SA560	TS4: XE5065-001
3	Wide table and free motion grip	SATFM6000D	TFM-3: XE5062-001
4	Embroidery frame set (large) H 18 cm x W 13 cm (H 7 inches x W 5 inches)	SA439	EF75: XC8481-052
5	Embroidery card Reader	SAECRI	
6	Embroidery card	-	
7	Stabilizer material	SA519	BM3: XE0806-001
	Water soluble stabilizer	SA520	BM5: XE0615-001
8	1/4 quilting foot with guide	SA185	F057: XC7416-252
9	Embroidery bobbin thread (white)	SAEBT	EBT-CEN: X81164-001
	Embroidery bobbin thread (black)	SAEBT999	EBT-CEBN: XC5520-001
10	Seam guide	SA538	SG1: XC8483-052
11	Embroidery positioning sticker x 6 (Snowman™ Embroidery Positioning Marker)	SAEPS1	EPS1: XE5096-001
12	Edge sewing sheet x 5	SAESS1	ESS1: XE5094-001

Memo

- All specifications are correct at the time of printing. Please be aware that some specifications may change without notice.

Note

- Embroidery cards purchased in foreign countries may not work with your machine.
- Visit your nearest authorized dealer for a complete listing of optional accessories and embroidery cards available for your machine.

Using the Spool Stand

The included spool stand is useful when using thread spools with a large diameter (cross-wound thread). The spool stand can hold two spools of thread.

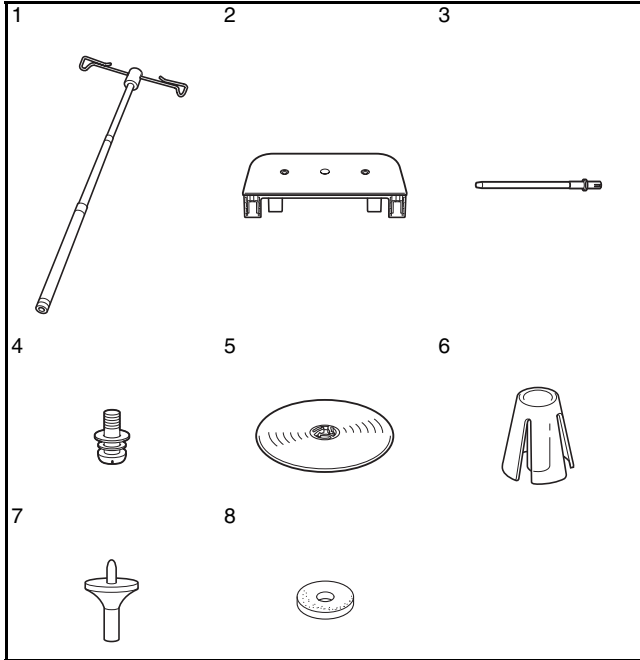

No.	Part Name	Part Code
1	Telescopic thread guide	XE0776-001
2	Spool support	XE4637-001
3	Spool pin × 2	XA6313-051
4	Screw and washer	XC7568-051
5	Spool cap (XL) × 2	XE0779-001
6	Spool holders × 2	XA0679-050
7	Spool cap base × 2	XE0780-001
8	Spool felt × 2	XC7134-051

⚠ CAUTION

- Do not lift the handle of the machine while the spool stand is installed.
- Do not push or pull the telescopic thread guide or spool pins with extreme force, otherwise damage may result.
- Do not place any object other than spools of thread on the spool support.
- Do not try to wind thread on the bobbin while sewing using the spool stand.

How to Assemble the Spool Stand

- 1 Fully extend the telescopic thread guide shaft, and then rotate the shaft until the two internal stoppers click into place.

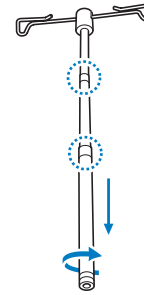

- 2 Insert the telescopic thread guide into the round hole at the center of the spool support, and then use a screwdriver to securely tighten the screw (①) from the reverse side.

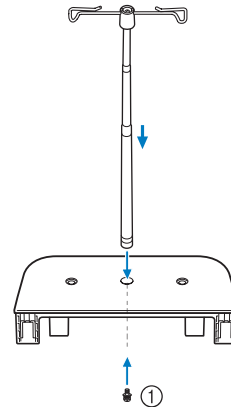

① Screw

💡 Note

- Make sure that the stoppers on the telescopic thread guide shaft are firmly in place and that the top of the thread guide is directly above the spool pins. In addition, check that the shaft is securely tightened in the spool support.

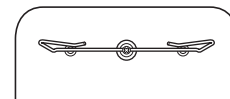

- 3** Firmly insert the two spool pins into the two holes in the spool support.

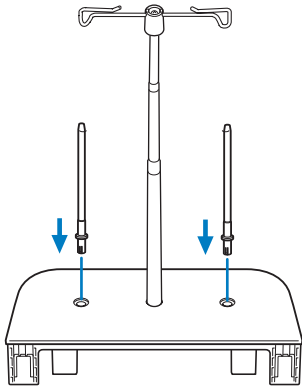

- 4** Open the upper cover of the machine. From the back of the machine, press in the upper cover latches (one on each side), and then pull the upper cover up to remove it from the machine.

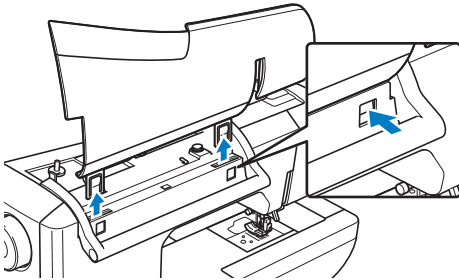

- 5** Insert the spool stand onto the notches of the machine.

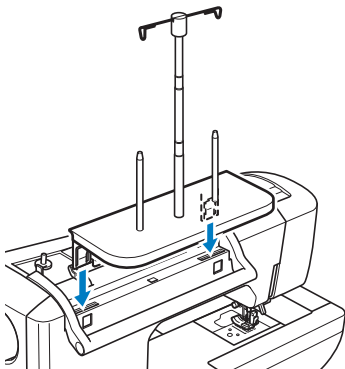

How to Remove

- 1** From the back of the machine, press in the spool stand latches (one on each side), and then pull the spool stand up to remove it from the machine.

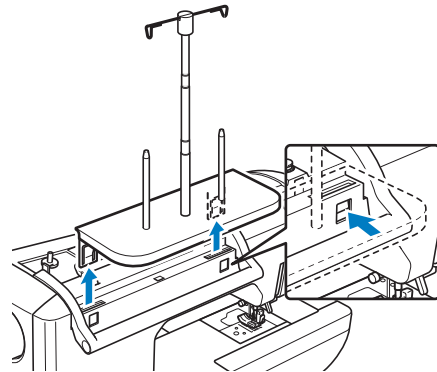

- 2** Attach the upper cover to the machine.

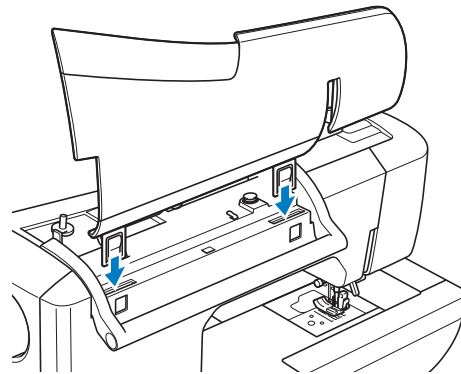

Memo

- See page 41 about the bobbin winding using the spool stand.
- See page 52 about the upper threading using the spool stand.



Chapter 1

Getting Ready

TURNING THE MACHINE ON/OFF 12

LCD SCREEN 14

- Home Page Screen 14
- Utility Stitch LCD Screen 15
- Key Functions 16

USB Connectivity 18

- Using USB Media or Embroidery Card Reader/
USB Card Writer Module* 18
- Connecting the Machine to the Computer 19
- Using a USB Mouse 19
- Clicking a Key 20
- Changing Pages 20

Using the Machine Setting Mode Key 22

- Changing the Pointer Shape When a USB Mouse Is Used 25
- Changing the Screen Saver Image 25
- Selecting the Initial Screen Display 28
- Choosing the Display Language 29
- Changing the Background Colors
of the Embroidery Patterns 30

Using the Sewing Machine Help Key 32

Using the Operation Guide Function 33

Using the Sewing Guide Function 34

Using the Pattern Explanation Function 35

LOWER THREADING 37

Winding the Bobbin 37

- Using the Supplemental Spool Pin 37
- Using the Spool Pin 40
- Using the Spool Stand 41
- Untangling Thread from Beneath the Bobbin Winder Seat 42

Setting the Bobbin 43

Pulling Up the Bobbin Thread 45

UPPER THREADING 46

Upper Threading 46

Using the Twin Needle Mode 49

Using the Spool Stand 52

- Using the Spool Stand 52

Using Threads that Unwind Quickly 53

- Using the Spool Net 53

CHANGING THE PRESSER FOOT 54

Removing the Presser Foot 54

Attaching the Presser Foot 54

Attaching the Walking Foot 55

CHANGING THE NEEDLE 56

About the Needle 58

Fabric/Thread/Needle Combinations 58

TURNING THE MACHINE ON/OFF

WARNING

- Use only regular household electricity for the power source. Using other power sources may result in fire, electric shock, or damage to the machine.
- Make sure that the plugs on the power cord are firmly inserted into the electrical outlet and the power cord receptacle on the machine.
- Do not insert the plug on the power cord into an electrical outlet that is in poor condition.
- Turn the main power to OFF and remove the plug in the following circumstances:
 - When you are away from the machine
 - After using the machine
 - When the power fails during use
 - When the machine does not operate correctly due to a bad connection or a disconnection
 - During electrical storms

CAUTION

- Use only the power cord included with this machine.
- Do not use extension cords or multi-plug adapters with many other appliances plugged in to them. Fire or electric shock may result.
- Do not touch the plug with wet hands. Electric shock may result.
- When unplugging the machine, always turn the main power to OFF first. Always grasp the plug to remove it from the outlet. Pulling on the cord may damage the cord, or lead to fire or electric shock.
- Do not allow the power cord to be cut, damaged, modified, forcefully bent, pulled, twisted, or bundled. Do not place heavy objects on the cord. Do not subject the cord to heat. These things may damage the cord, or cause fire or electric shock. If the cord or plug is damaged, take the machine to your authorized dealer for repairs before continuing use.
- Unplug the power cord if the machine is not to be used for a long period of time. Otherwise, a fire may result.
- When leaving the machine unattended, either the main switch of the machine should be turned to OFF or the plug must be removed from the socket-outlet.
- When servicing the machine or when removing covers, the machine must be unplugged.
- For U.S.A only
This appliance has a polarized plug (one blade wider than the other). To reduce the risk of electrical shock, this plug is intended to fit in a polarized outlet only one way.
If the plug does not fit fully in the outlet, reverse the plug. If it still does not fit, contact a qualified electrician to install the proper outlet. Do not modify the plug in any way.

- 1** Insert the power supply cord into the power cord receptacle, then insert the plug into a wall outlet.

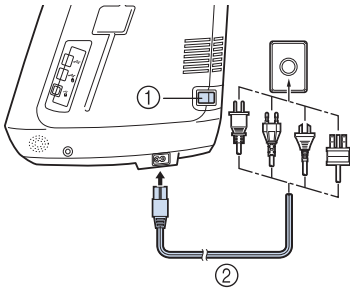

- ① Main power switch
② Power supply cord

- 2** Turn the main power switch to “I” to turn on the machine.

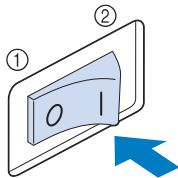

- ① OFF
② ON



Memo

- When the machine is turned on, the needle and the feed dogs will make sound when they move; this is not a malfunction.

- 3** Turn the main power switch to “O” to turn off the machine.

LCD SCREEN

When the machine is turned on, the opening movie is played. Touch anywhere on the screen for the home page screen to be displayed. Touch the LCD screen or a key with your finger or the included touch pen to select a machine function.



Note

- When the straight stitch needle plate is on the machine, the needle will automatically move to the middle position.



Memo

- Only touch the screen with your finger or the included touch pen. Do not use a sharp pencil, screwdriver, or other hard or sharp object. It is not necessary to press hard on the screen. Pressing too hard or using a sharp object may damage the screen.

■ Home Page Screen

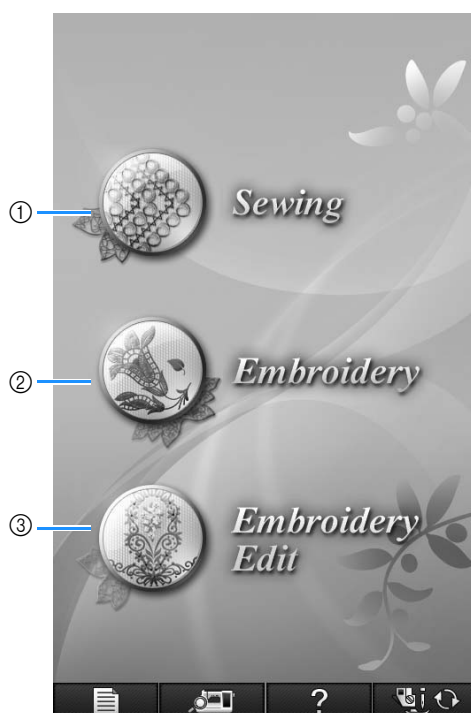

No.	Display	Key Name	Explanation	Page
①		Sewing key	Press this key to sew utility stitches or character or decorative stitch patterns.	See the "Key Functions" table. 16
②		Embroidery key	Attach the embroidery unit and press this key to embroider patterns.	182
③		Embroidery Edit key	Press this key to combine embroidery patterns. With the embroidery edit functions, you can also create original embroidery patterns or frame patterns.	262

Utility Stitch LCD Screen

Press a key with your finger to select the stitch pattern, to select a machine function, or to select an operation indicated on the key.

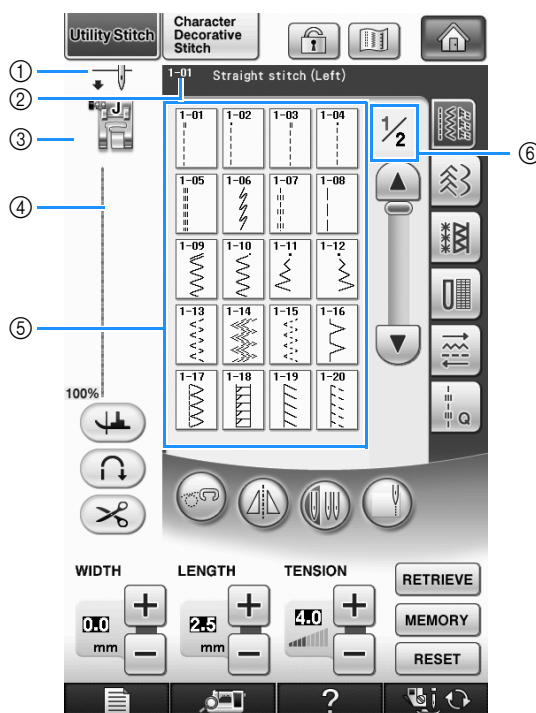

- ① Shows single or twin needle mode setting, and the needle stop position.

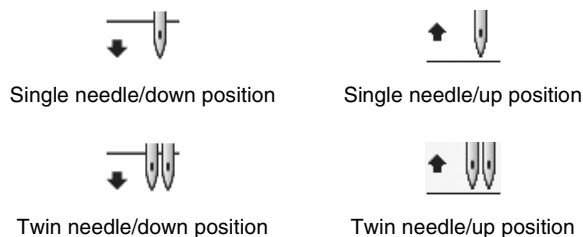





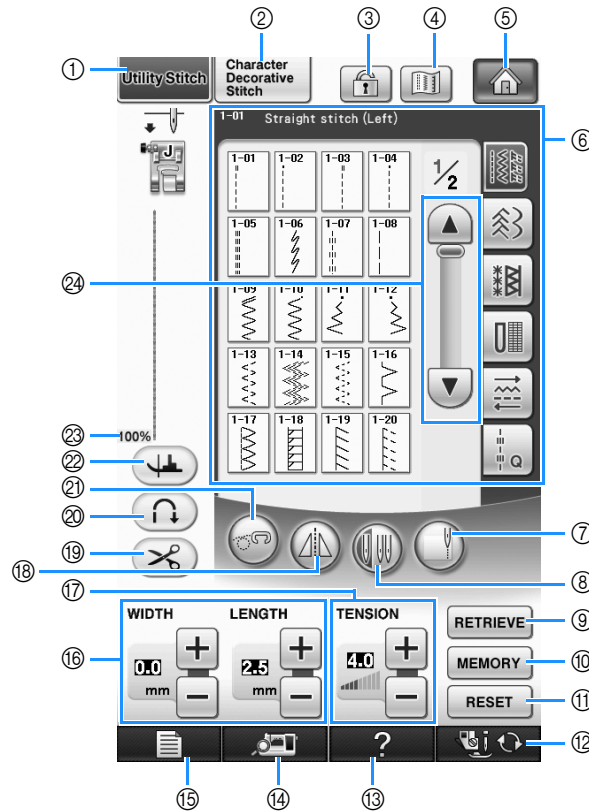







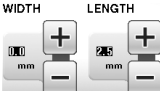

- ② Shows the name and code number of the selected stitch.
 ③ Shows the presser foot code. Attach the presser foot indicated in this display before sewing.
 ④ Shows a preview of the selected stitch.
 When shown at 100%, the stitch appears in the screen at nearly its actual size.
 ⑤ Shows the stitch patterns.
 ⑥ Shows additional pages that can be displayed (Illustration shows page 1 of 2.).
 * All key functions of the LCD are explained in the "Key Functions" table on the following page.

■ Key Functions



No.	Display	Key Name	Explanation	Page
①		Utility stitch key	Press this key to select a straight stitch, zigzag stitch, buttonhole, blind hem stitch, or other stitches commonly used in garment construction.	79
②		Character/Decorative stitch key	Press this key to select character or decorative stitch patterns.	146
③		Screen lock key	Press this key to lock the screen. When the screen is locked, the various settings, such as the stitch width and stitch length, are locked and cannot be changed. Press this key again to unlock the settings.	74
④		Image key	Press this key to display an enlarged image of the selected stitch pattern.	80
⑤		Home page screen key	Press this key anytime it is displayed to return to the home page screen and select a different category - "Sewing", "Embroidery" or "Embroidery edit".	14
⑥		Stitch selection display	Press the key for the pattern you want to sew. Use to change to different stitch groups.	79
⑦		Edge sewing key	Using the built-in camera, press this key to measure the width of the area from the edge of the fabric to the stitch and set the camera for edge sewing.	138
⑧		Needle mode selection key (single/double)	Press this key to select twin needle sewing mode. The sewing mode changes between single needle mode and twin needle mode each time you press the key. If the key display is light gray, the selected stitch pattern cannot be sewn in the twin needle mode.	49
⑨		Retrieve key	Press this key to retrieve a saved pattern.	82
⑩		Manual memory key	Change the stitch pattern settings (zigzag width and stitch length, thread tension, automatic thread cutting or automatic reinforcement stitching, etc.), then save them by pressing this key. Five sets of settings can be saved for a single stitch pattern.	81
⑪		Reset key	Press this key to return the selected stitch pattern saved settings to the default settings.	66-67

No.	Display	Key Name	Explanation	Page
12		Presser foot/Needle exchange key	Press this key before changing the needle, the presser foot, etc. This key locks all key and button functions to prevent operation of the machine.	54-57
13		Sewing machine help key	Press this key to see explanations on how to use the machine.	32
14		Camera view key	Touch this key to check the needle location as it is shown on the screen through the built in camera.	75
15		Machine setting mode key	Press this key to change the needle stop position, change the volume of operation beep, adjust the pattern or screen, and change other machine settings.	22
16		Stitch width and stitch length key	Shows the zigzag width and stitch length settings of the currently selected stitch pattern. You can use the plus and minus keys to adjust the zigzag width and stitch length settings.	66
17		Thread tension key	Shows the automatic thread tension setting of the currently selected stitch pattern. You can use the plus and minus keys to change the thread tension settings.	67
18		Mirror image key	Press this key to create a mirror image of the selected stitch pattern. If the key display is light gray, a mirror image of the selected stitch pattern cannot be sewn.	79
19		Automatic thread cutting key	Press this key to set the automatic thread cutting function. Set the automatic thread cutting function before sewing to have the machine automatically sew reinforcement stitches at the beginning and end of sewing (depending on the pattern, the machine may sew reverse stitches) and trim the threads after sewing.	69
20		Automatic reinforcement stitch key	Press this key to use the automatic reinforcement stitching (reverse stitching) setting. If you select this setting before sewing, the machine will automatically sew reinforcement stitches at the beginning and end of sewing (depending on the pattern, the machine may sew reverse stitches).	69
21		Free motion mode key	Press this key to enter free motion sewing mode. The presser foot is raised to an appropriate height and the feed dog is lowered for free motion quilting.	105
22		Pivot key	Press this key to select the pivot setting. When the pivot setting is selected, stopping the machine lowers the needle and slightly raises the presser foot automatically. In addition, when sewing is restarted, the presser foot is automatically lowered. <ul style="list-style-type: none">• If this key appears as  , the pivot function cannot be used.• Be sure the needle position on page 23 of Machine Settings is set to the down position.	72
23	100%	Pattern display size	Shows the approximate size of the pattern selected. 100% : Nearly the same size as the sewn pattern 50% : 1/2 the size of the sewn pattern 25% : 1/4 the size of the sewn pattern * The actual size of the sewn pattern may differ depending on the type of fabric and thread that is used.	79
24		Scroll key	Press  or  , to move one page at a time, or touch anywhere on the bar to jump ahead for additional pages of stitches.	

USB Connectivity

You can perform many functions using the USB ports on the machine. Connect the appropriate devices according to the feature of each ports.

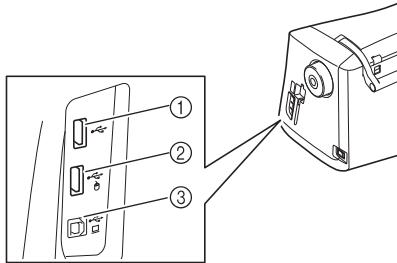

- ① Primary (top) USB port for media or card Reader/USB card writer module* (USB2.0)
- * If you have purchased the PE-DESIGN Ver5 or later, PE-DESIGN Lite or PED-BASIC, you can plug the included USB card writer module into the machine as an embroidery card reader, and recall patterns.
- ② USB port for mouse (USB1.1)
- ③ USB port for computer



Note

- The processing speed may vary by port selection and quantity of data.
- Do not insert anything other than USB media into the USB media port. Otherwise, the USB media drive may be damaged.

■ Using USB Media or Embroidery Card Reader/USB Card Writer Module*

When sending or reading patterns using the USB media or the embroidery card Reader/USB card writer module*, connect the device to the primary (top) USB port.

The primary (top) USB port processes the data faster than the other ports.

- * If you have purchased the PE-DESIGN Ver5 or later, PE-DESIGN Lite or PED-BASIC, you can plug the included USB card writer module into the machine as an embroidery card reader, and recall patterns.

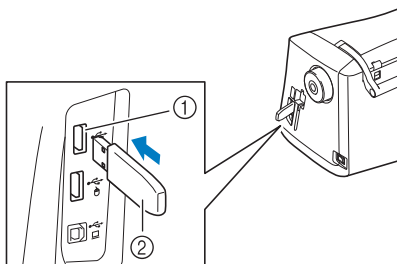

- ① Primary (top) USB port
- ② USB media

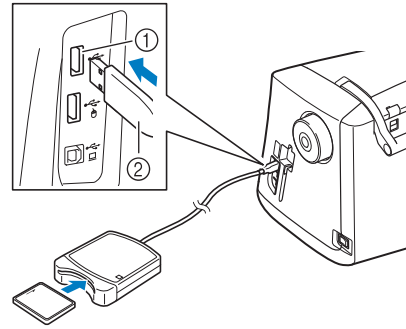

- ① Primary (top) USB port
- ② Embroidery card Reader/USB card writer module*



Note

- Two USB media cannot be used with this machine at the same time. If two USB media are inserted, only the USB media inserted first is detected.
- Use only an embroidery card reader designed for this machine. Using an unauthorized embroidery card reader may cause your machine to operate incorrectly.
- Embroidery patterns cannot be saved from the machine to an embroidery card inserted into a connected USB card writer module.



Memo

- USB media is widely used, however some USB media may not be usable with this machine. Please visit our website for more details.
- Depending on the type of USB media being used, either directly plug the USB device into the machine's USB port or plug the USB media Reader/Writer into the machine's USB port.
- You can plug the optional embroidery card Reader/USB card writer module* into the primary (top) or center port, when the mouse is not connected.
- You can plug a USB media into the center port, but the primary (top) USB port processes the data faster. It is recommended to use the primary (top) USB port.

■ Connecting the Machine to the Computer

Using the included USB cable, the sewing machine can be connected to your computer.

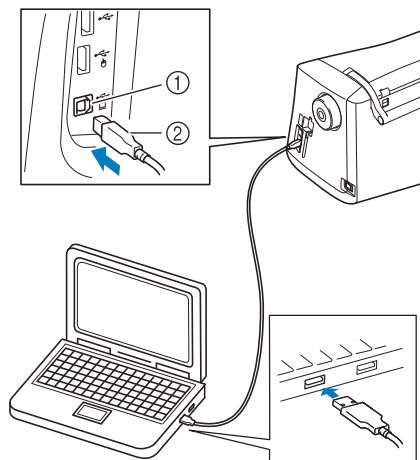

- ① USB port for computer
- ② USB cable connector



Note

- The connectors on the USB cable can only be inserted into a port in one direction. If it is difficult to insert the connector, do not insert it with force. Check the orientation of the connector.
- For details on the position of the USB port on the computer (or USB hub), refer to the instruction manual for the corresponding equipment.

■ Using a USB Mouse

The USB mouse, connected to the sewing machine, can be used to perform a variety of operations in the screens.

Connect a USB mouse to the USB 1.1 port marked with . You can also connect a USB mouse to the other USB port (USB 2.0).

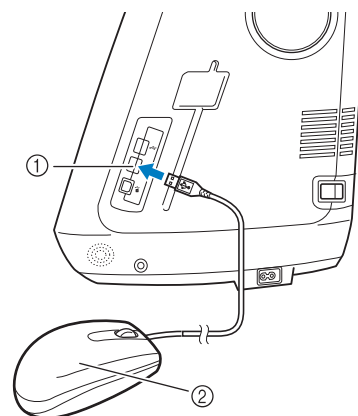

- ① USB port for mouse
- ② USB mouse



Note

- Do not perform operations with the mouse at the same time that you are touching the screen with your finger or the included touch pen.
- A USB mouse can be connected or disconnected at any time.
- Only the left mouse button and its wheel can be used to perform operations. No other buttons can be used.
- The mouse pointer does not appear in the camera view window, the screen saver or the home page screen.

■ Clicking a Key

When the mouse is connected, the pointer appears on the screen. Move the mouse to position the pointer over the desired key, and then click the left mouse button.

Memo

- Double-clicking has no effect.

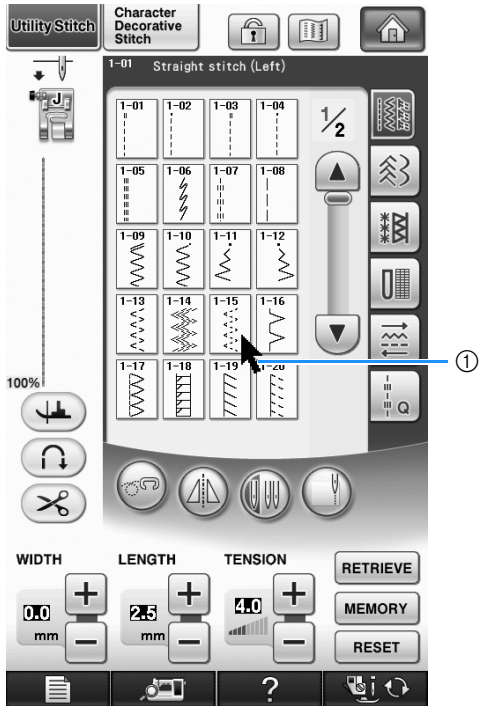



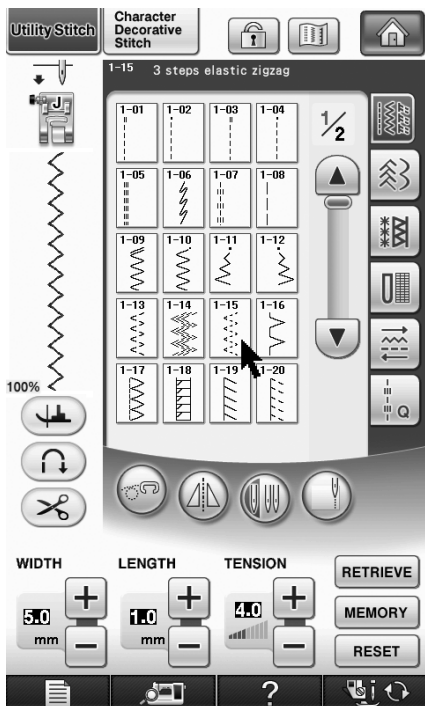
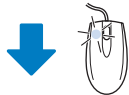

① Pointer



■ Changing Pages

Rotate the mouse wheel to switch through the tabs of the pattern selection screens.



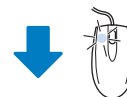
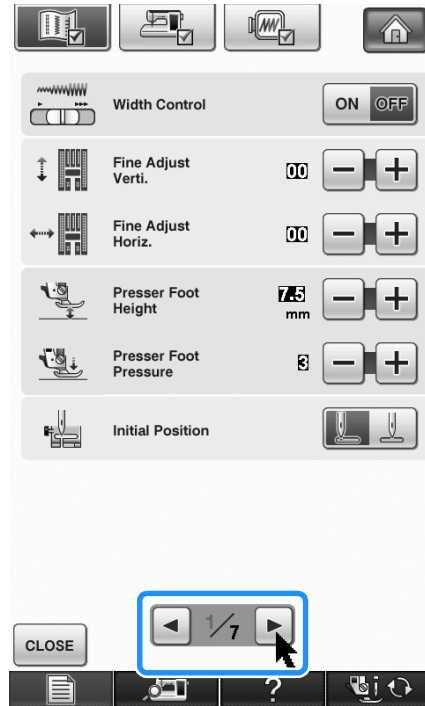

Memo

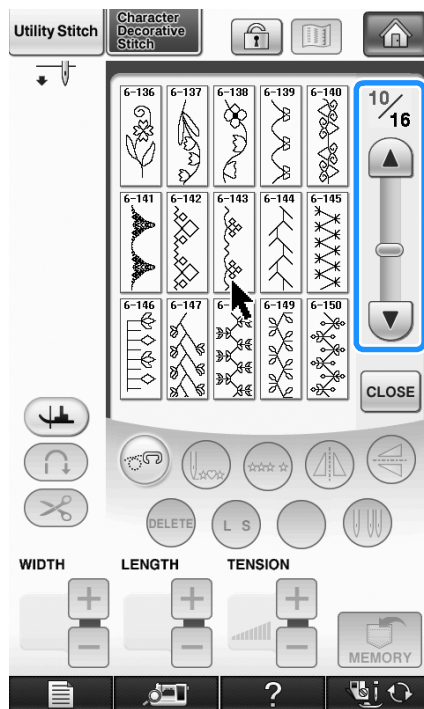
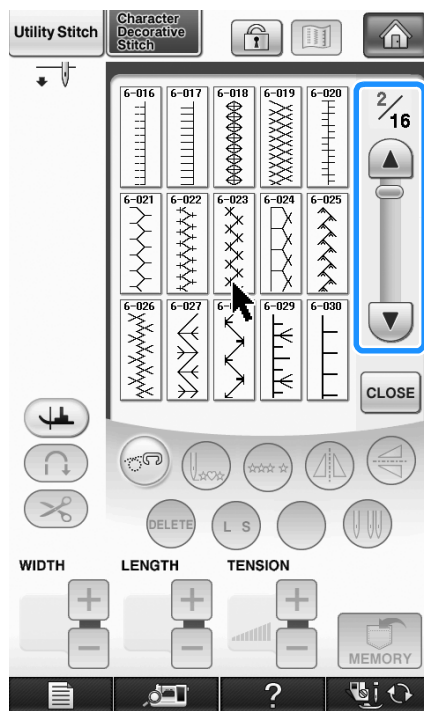
- If page numbers and a vertical scroll bar for additional pages are displayed, rotate the mouse wheel or click the left mouse button with the pointer on  /  or  /  to display the previous or next page.





Using the Machine Setting Mode Key

Press  to change the default machine settings (needle stop position, embroidery speed, opening display, etc.). To display the different settings screens, press  for “Sewing settings”,  for “General settings” or  for “Embroidery settings”.

Memo

- Press  or  to display a different settings screen.

Sewing settings

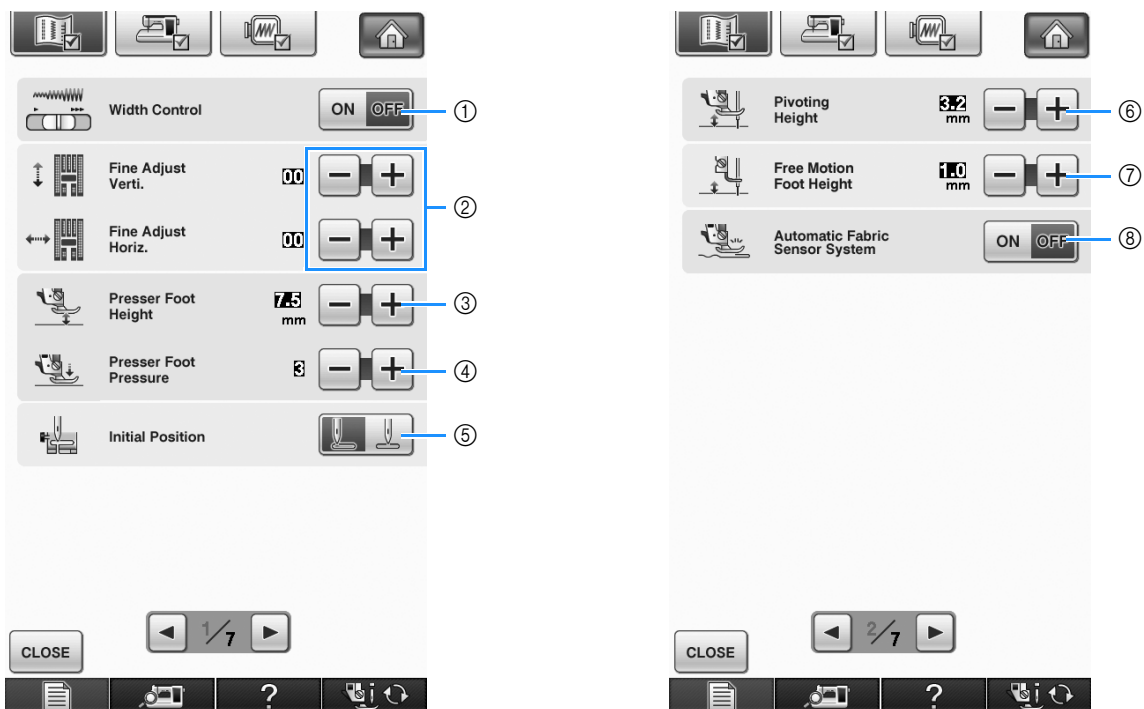

- ① Select whether to use the sewing speed controller to determine the zigzag width (see page 104).
- ② Make adjustments to character or decorative stitch patterns (see page 153).
- ③ Adjust the presser foot height. (Select the height of the presser foot when the presser foot is raised.)
- ④ Adjust the presser foot pressure. (The higher the number, the greater the pressure will be. Set the pressure at “3” for normal sewing.)
- ⑤ Select whether “1-01 Straight stitch (Left)” or “1-03 Straight stitch (Middle)” is the utility stitch that is automatically selected when the machine is turned on.
- ⑥ Change the height of the presser foot when sewing is stopped when the pivot setting is selected (see page 72). Adjust the presser foot to one of the three heights (3.2 mm, 5.0 mm and 7.5 mm).
- ⑦ Change the height of the presser foot when the machine is set to free motion sewing mode (see page 105).
- ⑧ When set to “ON”, the thickness of the fabric is automatically detected by an internal sensor while sewing. This enables the fabric to be fed smoothly (see pages 64 and 73).

General settings

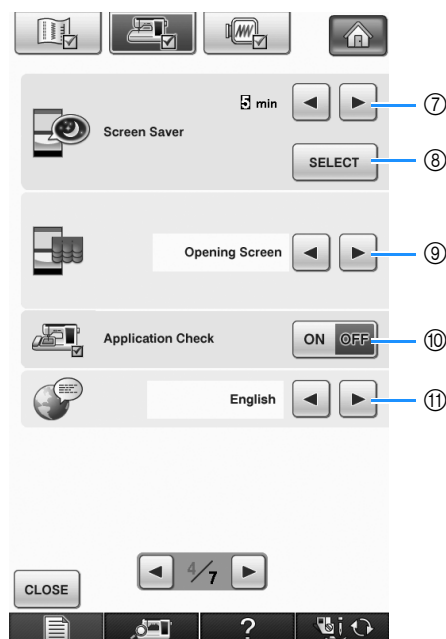
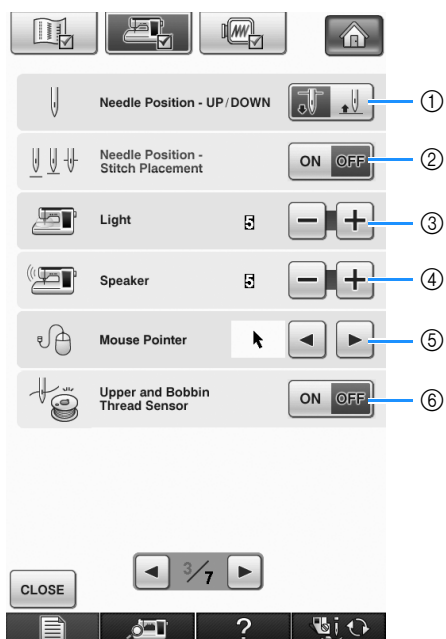

⚠ CAUTION

- If “Upper and Bobbin Thread Sensor” is set to “OFF”, remove the upper thread. If the machine is used with the upper thread threaded, the machine will not be able to detect if the thread has become tangled. Continuing to use the machine with tangled thread may cause damage.

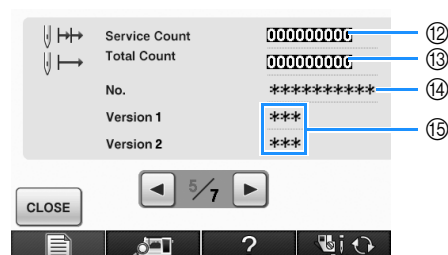

- ① Select the needle stop position (the needle position when the machine is not operating) to be up or down. Select the down position when using the pivot key.
- ② Select the operation of the “Needle Position - Stitch Placement” button from the following two sequences (see page 74).
Each press of the “Needle Position - Stitch Placement” button:
“ON” – raises the needle, stops it at a nearly lowered position, then lowers it
“OFF” – raises the needle, then lowers it
- ③ Change the brightness of the Needle Area and Work Area Lights.
- ④ Change the speaker volume.
- ⑤ Change the shape of the pointer when a USB mouse is used (see page 25).
- ⑥ Turn both the upper and bobbin thread sensor “ON” or “OFF”. If it is turned “OFF”, the machine can be used without thread.
- ⑦ Select the length of time until the screen saver appears. A setting between “OFF” (0) and “60” minutes can be set in 1-minute increments.
- ⑧ Change the image of the screen saver (see page 25).
- ⑨ Select the initial screen that is displayed when the machine is turned on (see page 28).
- ⑩ Use when running an application.
- ⑪ Change the display language (see page 29).
- ⑫ Display the service count which is a reminder to take your machine in for regular servicing. (Contact your authorized dealer for details.)
- ⑬ Display the total number of stitches.
- ⑭ The “No.” is the number for the embroidery and sewing machine.
- ⑮ Display the program version. “Version 1” shows the program version of the LCD panel, “Version 2” shows the program version of the machine.

Memo

- The latest version of software is installed in your machine. Check with your local authorized Brother dealer or at “<http://solutions.brother.com>” for available updates (see page 344).

Embroidery settings

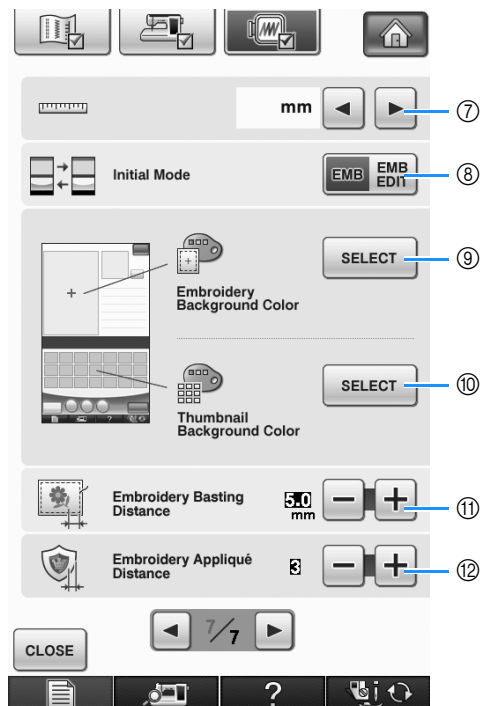
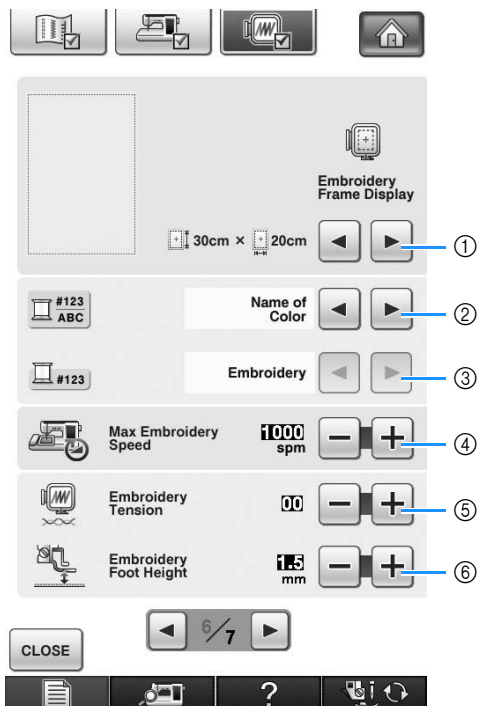

- ① Select from among 14 embroidery frame displays (see page 232).
- ② Change the thread color display on the embroidery screen; thread number, color name (see page 231).
- ③ When the thread number “#123” is selected, select from six thread brands (see page 231).
- ④ Adjust the maximum embroidery speed setting (see page 231).
- ⑤ Adjust the upper thread tension for embroidering (see page 227).
- ⑥ Select the height of the embroidery foot “W” during embroidering (see page 198).
- ⑦ Change the display units (mm/inch).
- ⑧ Change the initial mode of the display (embroidery/embroidery edit).
- ⑨ Change the color of the background for the embroidery display area (see page 30).
- ⑩ Change the color of the background for the thumbnail area (see page 30).
- ⑪ Adjust the distance between the pattern and the basting stitching (see page 295).
- ⑫ Adjust the distance between the appliqué pattern and the outline (see page 296).

■ Changing the Pointer Shape When a USB Mouse Is Used

In the settings screen, the shape can be selected for the pointer that appears when a USB mouse is connected. Depending upon the background color, select the desired shape from the three that are available.

Memo

- For details on changing the background color, refer to “Changing the Background Colors of the Embroidery Patterns” on page 30.

1 Press .



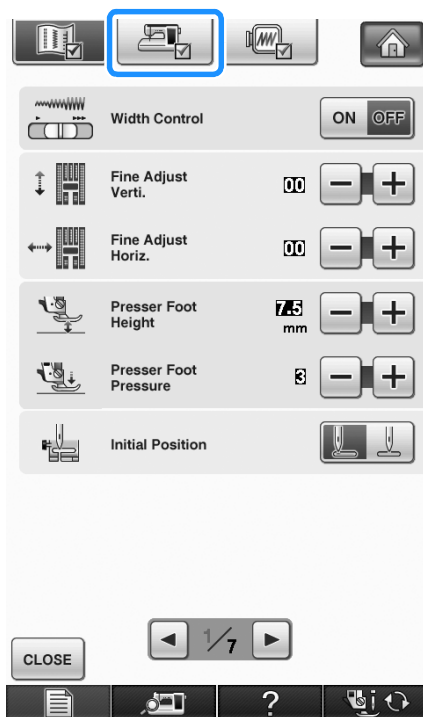

→ The Sewing settings screen appears.

2 Press .



→ The General settings screen appears.

3 Display 3/7 (page 3 of 7) of the General settings screen.

4 Use  and  to choose the pointer shape from the three settings available (,  and ).

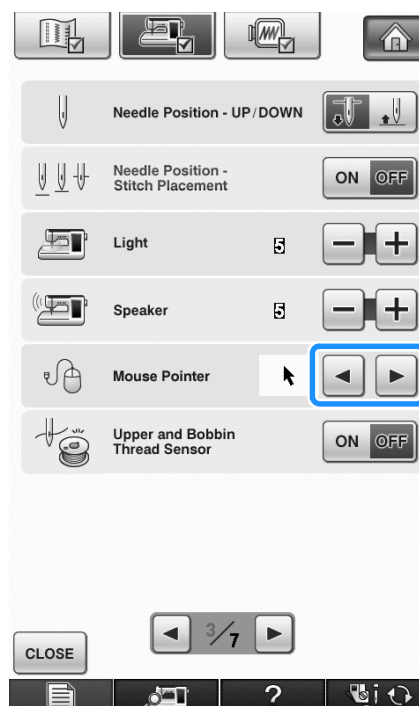

5 Press  to return to the original screen.

Memo

- The setting remains selected even if the machine is turned off.

■ Changing the Screen Saver Image

Instead of the default image, you can select your own personal images for the screen saver of your machine.

Before changing the screen saver image, prepare the image on your computer or USB media.

Compatible image files

Format	JPEG format (.jpg)
File size	Max. 150 KB for each image
File dimension	480 × 800 pixels or less, (If the width is more than 480 pixels, the image imported will be reduced to a width of 480 pixels.)
Number allowed	5 or less

Note

- When using USB media, make sure that it contains only your own personal images to be selected for the screen saver.
- Folders are recognized. Open the folder that holds your personal images.

1 Press  .

→ The Sewing settings screen appears.

2 Press  .

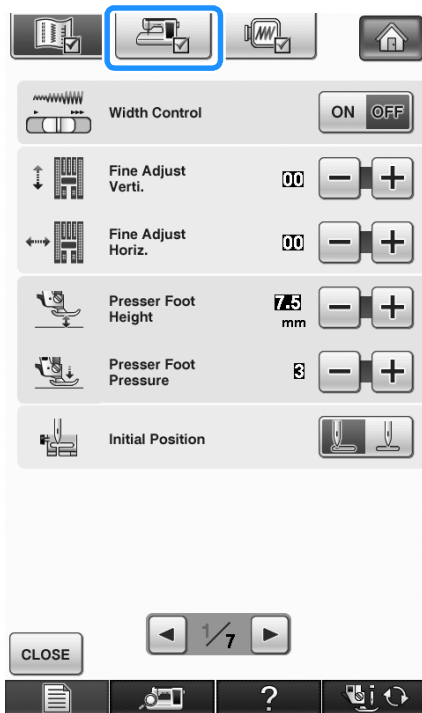

→ The General settings screen appears.

3 Display 4/7 (page 4 of 7) of the General settings screen.

4 Press  .



5 Press  .

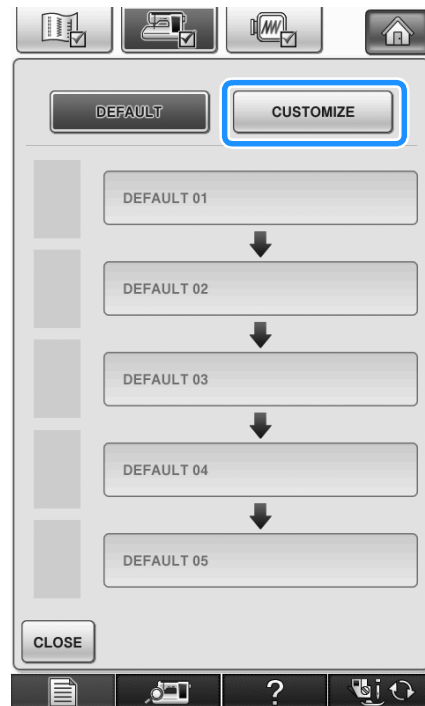

6 Connect the USB media or the computer (using a USB cable) that contains your personal image to the USB port of the machine.

* See page 18 about USB connectivity.

7 Press **CUSTOMIZE 01** to select the first image.

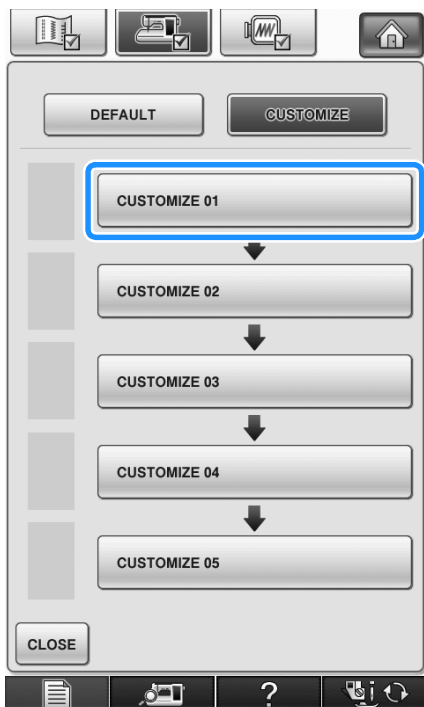

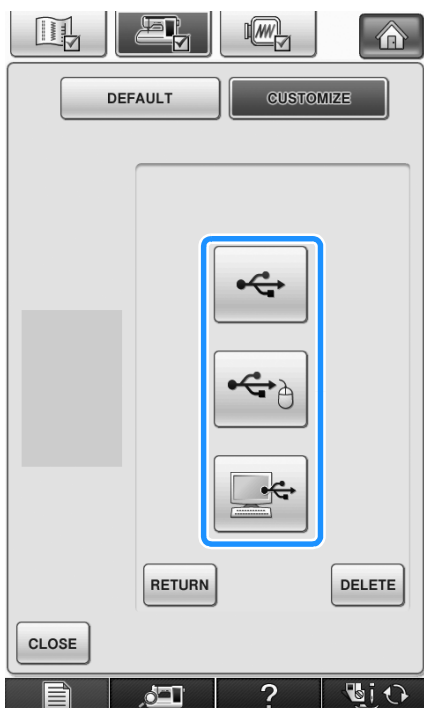

* The images will appear in a list in this screen. Select the desired number to specify the image.

8 Select the device that is connected.



* Press  when connecting USB media to the primary (top) USB port.

* Press  when connecting USB media to the center USB port.

* Press  when connecting a computer using a USB cable, and then copy your personal images into "Removable Disk", which appears on the desktop of the computer.

→ A list of your personal images appear on the screen.

* Press **DELETE** to delete the selected image.

* Press **RETURN** to view the previous page.

9 Press a file name to select image and then press **SET**.

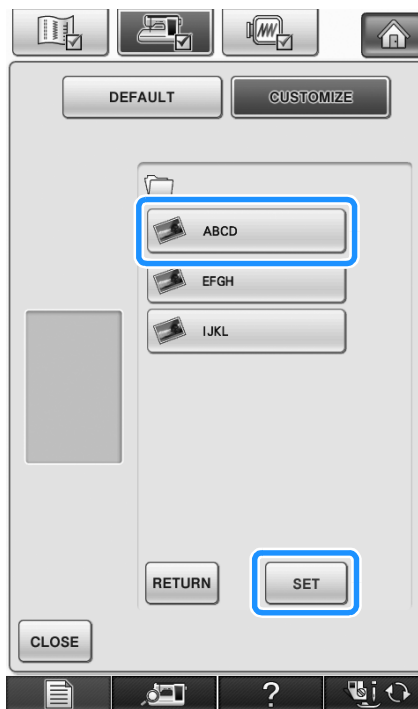

→ The selected image is stored on your machine.

* Press **RETURN** to view the previous page.

10 Repeat the procedure from step 7 to select the remaining images.

11 Press **CLOSE** to return to the original screen.

■ Selecting the Initial Screen Display

The Initial screen that appears on the machine can be changed.

1 Press .

→ The Sewing settings screen appears.

2 Press .

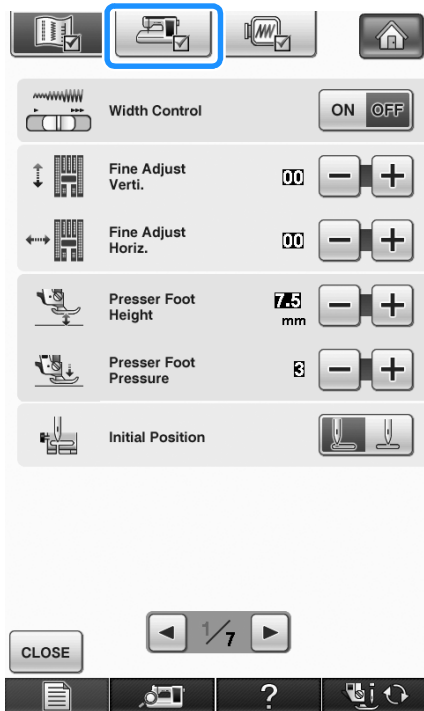

→ The General settings screen appears.

3 Display 4/7 (page 4 of 7) of the General settings screen.

4 Use  and  to select the setting for the initial screen display.

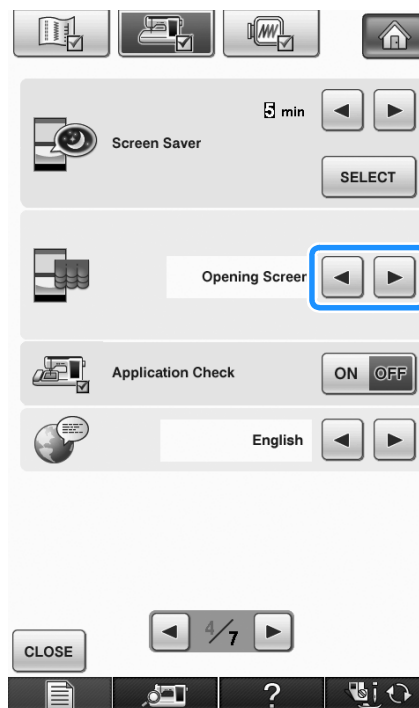

- * **Opening Screen:** When the machine is turned on, the home page screen appears after the opening movie screen is touched.
- * **Home Page:** When the machine is turned on, the home page screen appears.
- * **Sewing/Embroidery Screen:** When the machine is turned on, the Embroidery screen appears if the embroidery unit is attached to the machine, or the sewing screen appears if the embroidery unit is not attached to the machine.

5 Press  to return to the original screen.

■ Choosing the Display Language

1 Press .

→ The Sewing settings screen appears.

2 Press .

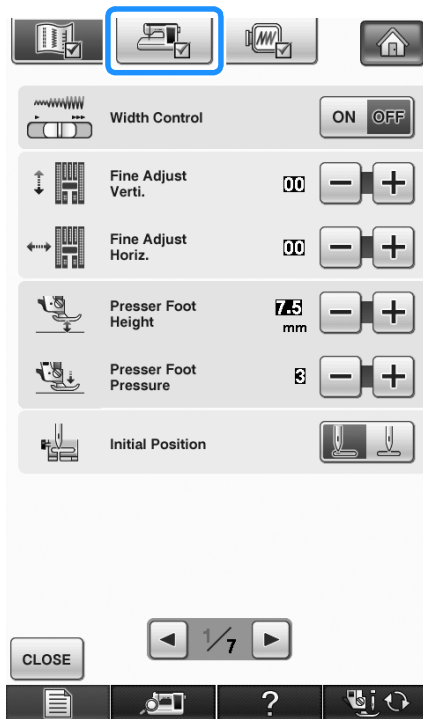

→ The General settings screen appears.

3 Display 4/7 (page 4 of 7) of the General settings screen.

4 Use  and  to choose the display language.

- * Choose from the following languages: "English", "Deutsch (German)", "Français (French)", "Italiano (Italian)", "Nederlands (Dutch)", "Español (Spanish)", "Dansk (Danish)", "Norsk (Norwegian)", "Suomi (Finnish)", "Svenska (Swedish)", "Português (Portuguese)", "Русский (Russian)".

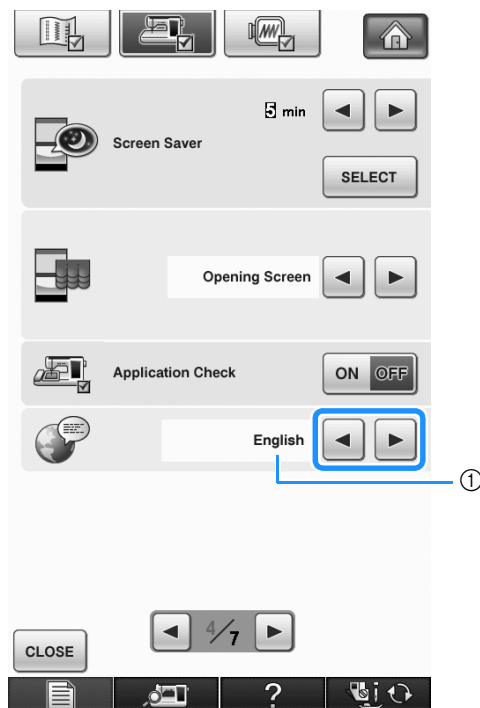

① Display language

5 Press  to return to the original screen.

1

Getting Ready

■ Changing the Background Colors of the Embroidery Patterns

In the settings screen, the background colors can be changed for the embroidery pattern and pattern thumbnails. Depending on the pattern color, select the desired background color from the 66 settings available. Different background colors can be selected for the embroidery pattern and pattern thumbnails.

1 Press .

→ The Sewing settings screen appears.

2 Press .

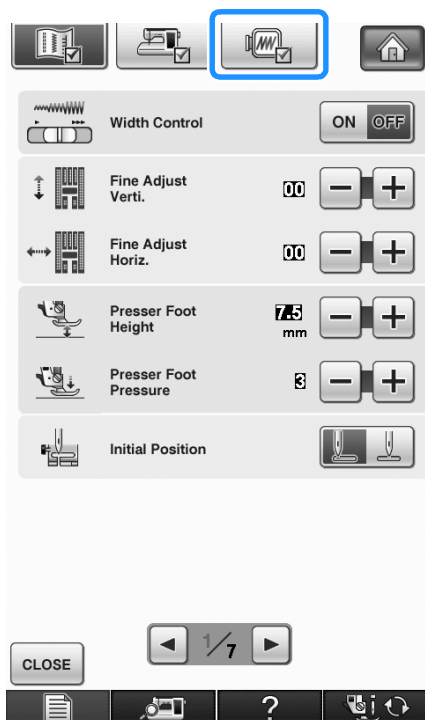

→ The Embroidery settings screen appears.

Memo

- When using the Embroidery or Embroidery Edit, touch  to directly access the Embroidery settings screen.

3 Display 7/7 (page 7 of 7) of the Embroidery settings screen.

4 Press .

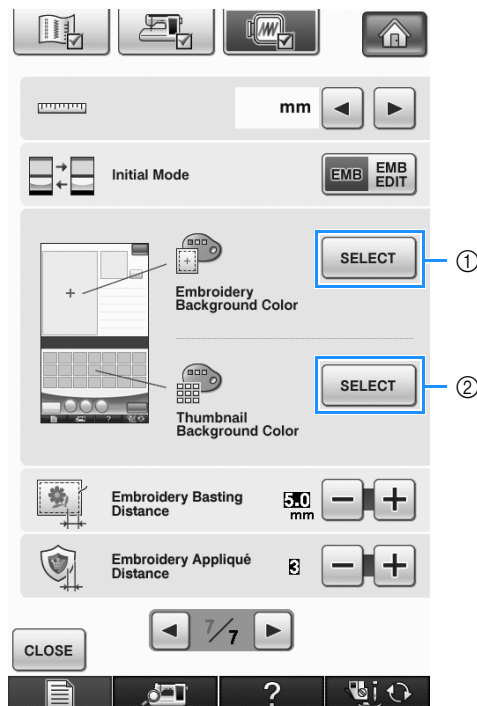

- ① Embroidery pattern background
- ② Pattern thumbnails background

- 5** Select the background color from the 66 settings available.

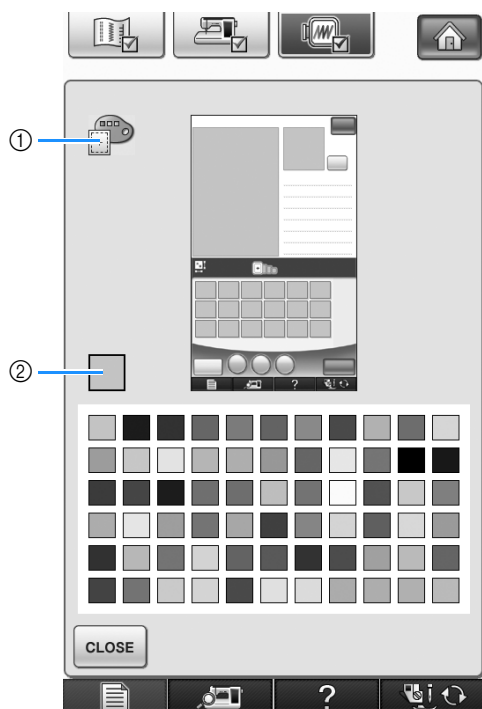

- ① Embroidery pattern background
② Selected color

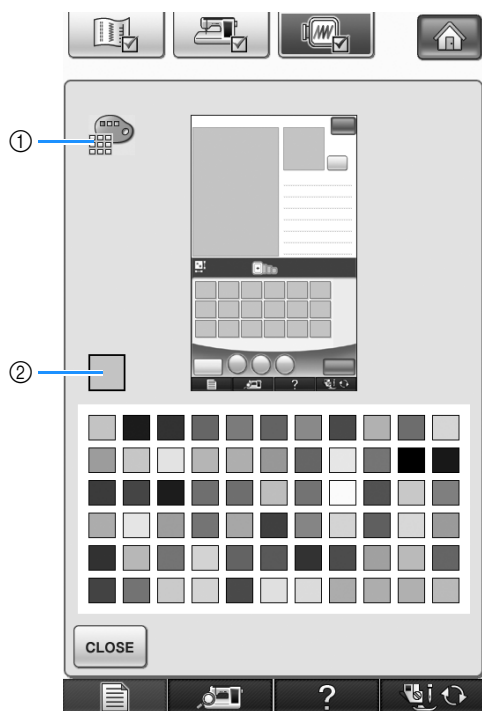

- ① Pattern thumbnails background
② Selected color

- 6** Press **CLOSE** to return to the original screen.



Memo

- The setting remains selected even if the machine is turned off.

Using the Sewing Machine Help Key

Press  to open the sewing machine help screen. Three functions are available from the screen shown below.

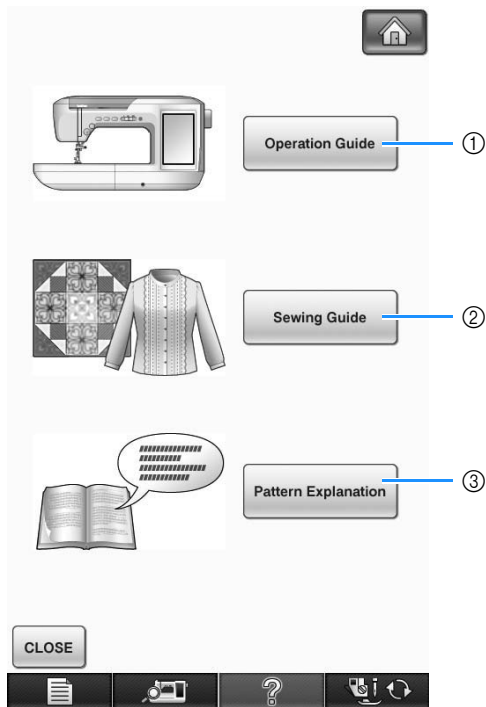

- ① Press this key to see explanation for upper threading, winding the bobbin, changing the presser foot, preparing to embroider a pattern, and how to use the machine (see page 33).
- ② Press this key to select utility stitches when you are not sure which stitch to use or how to sew the stitch (see page 34).
- ③ Press this key to see an explanation of the stitch selected (see page 35).

Using the Operation Guide Function

Press **Operation Guide** to open the screen shown below. Six categories are displayed at the top of the screen. Press a key to see more information about that category.

Principal Parts displays information about the main parts of the machine and their functions. This is the first screen displayed when you press **Operation Guide**.

Principal Buttons displays information about the operation buttons.

Basic Operation displays information about threading the machine, changing presser feet, etc. Some of the functions are described in the movies. Watch these movies for a better understanding of the functions.

Embroidery Basic Operation displays information about attaching the embroidery unit, preparing fabric for embroidering, etc. Some of the functions are described in the movies. Watch these movies for a better understanding of the functions.

Troubleshooting displays troubleshooting information.

Maintenance displays information about cleaning the machine, etc. Some of the functions are described in the movies. Watch these movies for a better understanding of the functions.

Example: Displaying information about upper threading

1 Press  .

2 Press  .

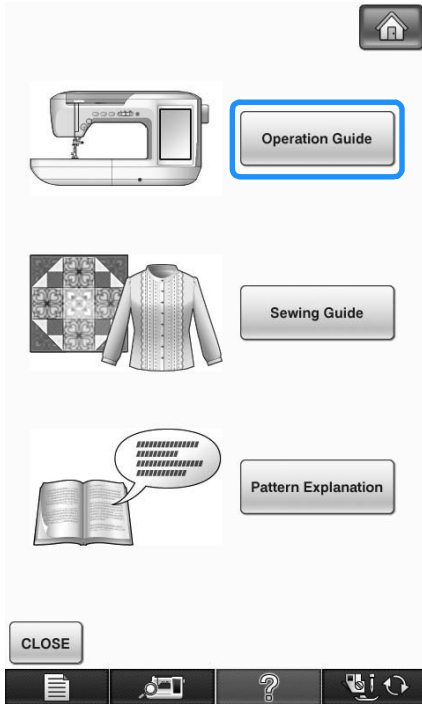

3 Press  .

→ The lower half of the screen will change.

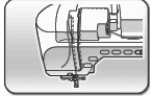
4 Press  (upper threading).

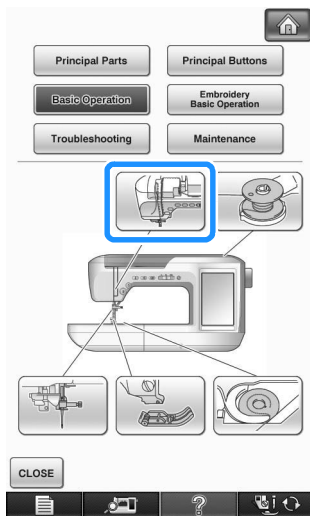

→ The screen shows instructions for threading the machine.

5 Read the instructions.

* Press  to see a video of the displayed instructions.

Press  under movie to go back to the

beginning. Press  to pause. Press  to

restart after pause. Press  to close out the movie.

* Press  to view the next page.

* Press  to view the previous page.

6 Press  to return to the original screen.

Using the Sewing Guide Function

The sewing guide function can be used to select patterns from the Utility Stitch screen. Use this function when you are not sure which stitch to use for your application, or to get advice about sewing particular stitches. For example, if you want to sew overcasting, but you do not know which stitch to use or how to sew the stitch, you can use this screen to get advice. We recommend that beginners use this method to select stitches.

1 Enter Utility Stitch category from the home page.

2 Press  .

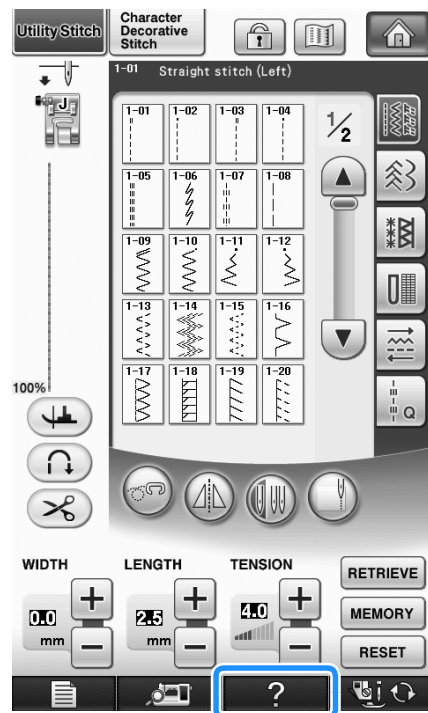

3 Press **Sewing Guide**.

→ The advice screen is displayed.

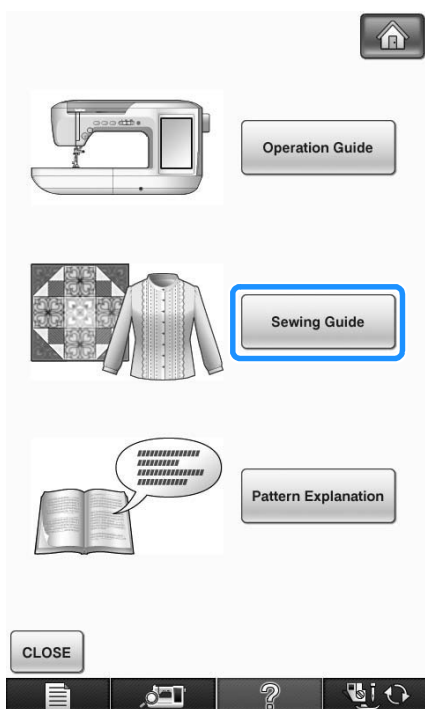

4 Press the key of the category whose sewing instructions you wish to view.

* Press **CLOSE** to return to the original screen.

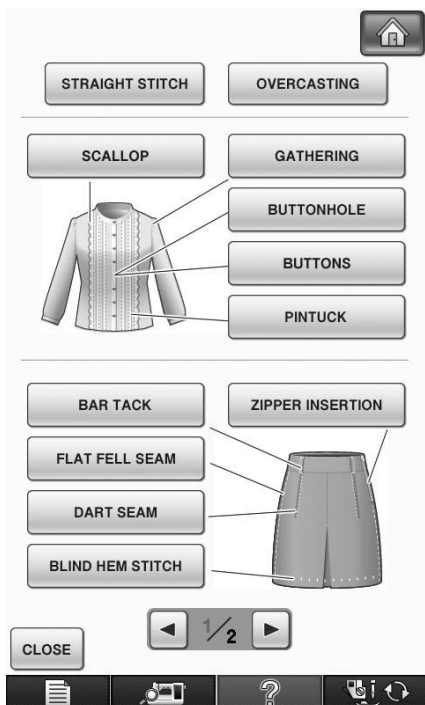

5 Read the explanations and select the appropriate stitch.

→ The screen displays directions for sewing the selected stitch. Follow the directions to sew the stitch.

Using the Pattern Explanation Function

If you want to know more about the uses of a stitch pattern, select the pattern and press **?** and then **Pattern Explanation** to see an explanation of the stitch selection.



Note

- With the pattern explanation function, descriptions can be displayed for the patterns available on the Utility Stitch and Character/Decorative Stitch screens.
- Descriptions are displayed for each pattern in the Utility Stitch screen. Description for the Character/Decorative Stitch category is also displayed.
- If the **Pattern Explanation** key appears in gray, the pattern explanation function cannot be used.

Example: Displaying information about **4-01**



1 Press **4-01**.

2 Press **?**.

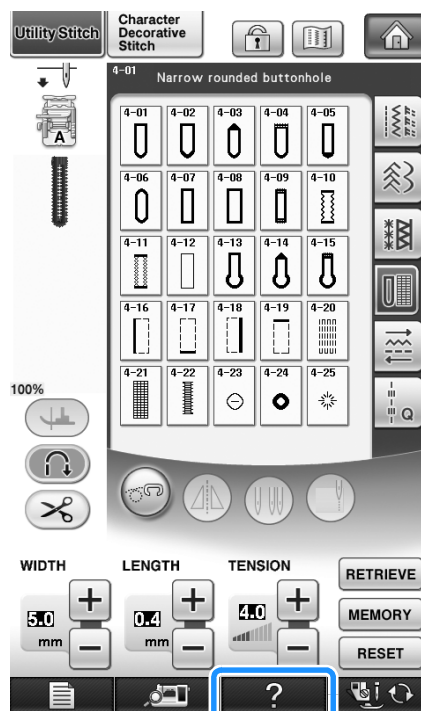

3 Press **Pattern Explanation**.

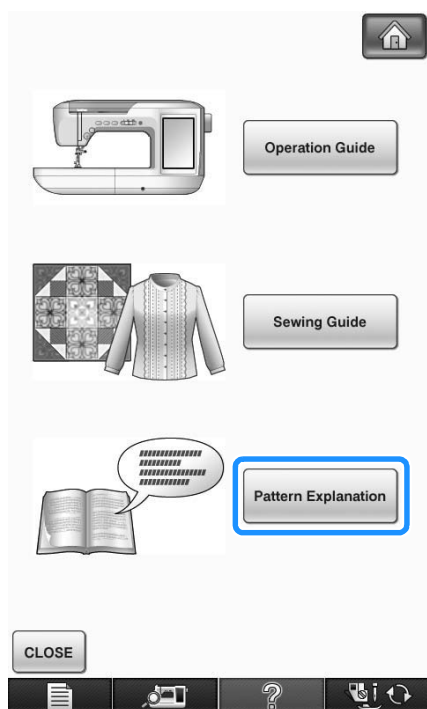

→ The screen shows information.

4 Press **CLOSE** to return to the original screen.

Memo

- The settings remain displayed to allow you to fine tune the stitch.

LOWER THREADING

1

Getting Ready

Winding the Bobbin

Press **?** → **Operation Guide** → **Basic Operation** →

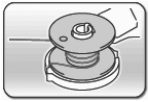

→ in this order to display a

video example of bobbin winding on the LCD (see page 34). Follow the steps explained below to complete the operation.

! CAUTION

- The included bobbin was designed specifically for this sewing machine. If bobbins from other models are used, the machine will not operate correctly. Use only the included bobbin or bobbins of the same type (part code: SA156, (SFB: XA5539-151)).

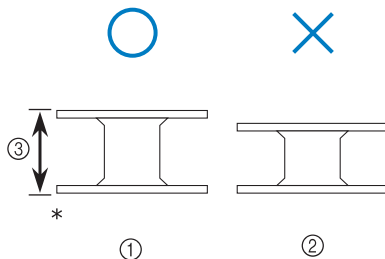

- * Actual size
- ① This model
- ② Other models
- ③ 11.5 mm (approx. 7/16 inch)

■ Using the Supplemental Spool Pin

With this machine, you can wind the bobbin during sewing. While using the main spool pin to sew embroidery, you can conveniently wind the bobbin using the supplemental spool pin.

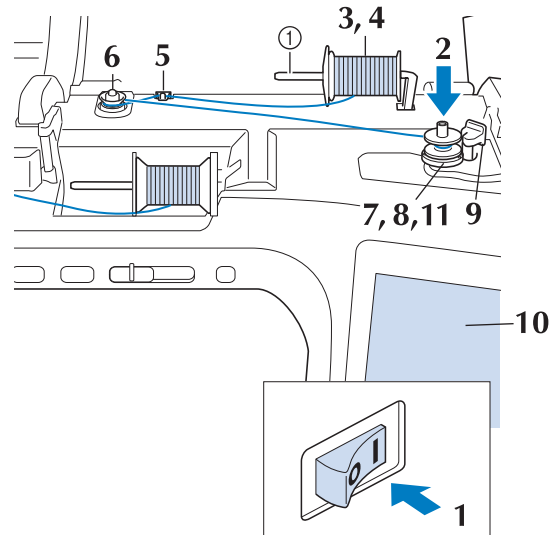

- ① Supplemental spool pin

- Turn the main power to ON and open the top cover.
- Align the groove in the bobbin with the spring on the bobbin winder shaft, and set the bobbin on the shaft.

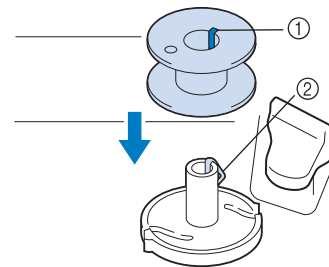

- ① Groove in the bobbin
- ② Spring on the shaft

3 Set the supplemental spool pin in the “up” position.

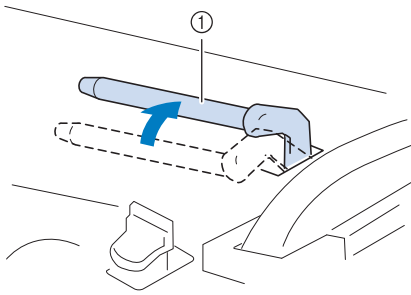

① Supplemental spool pin

4 Place the spool of thread on the supplemental spool pin, so that thread unrolls from the front. Push the spool cap onto the spool pin as far as possible to secure the thread spool.

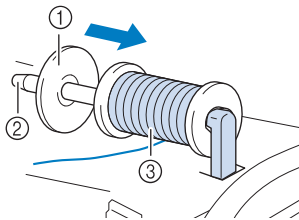

① Spool cap
② Spool pin
③ Thread spool

CAUTION

- If the thread spool and/or spool cap are set incorrectly, the thread may tangle on the spool pin and cause the needle to break.
- Use the spool cap (large, medium, or small) that is closest in size to the thread spool. If a spool cap smaller than the thread spool is used, the thread may become caught in the slit on the end of the spool and cause the needle to break.

Memo

- When sewing with fine, cross-wound thread, use the small spool cap, and leave a small space between the cap and the thread spool.

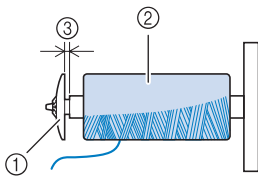

① Spool cap (small)
② Thread spool (cross-wound thread)
③ Space

5 With your right hand, hold the thread near the thread spool. With your left hand, hold the end of the thread, and use both hands to pass the thread through the thread guide.

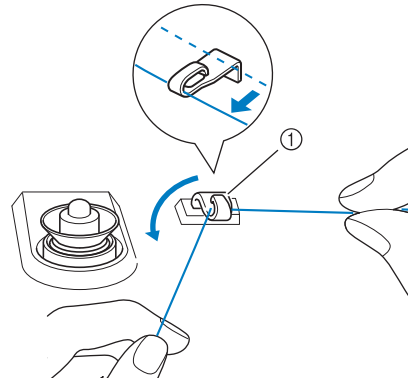

① Thread guide

6 Pass the thread around the pre-tension disk making sure that the thread is under the pre-tension disk.

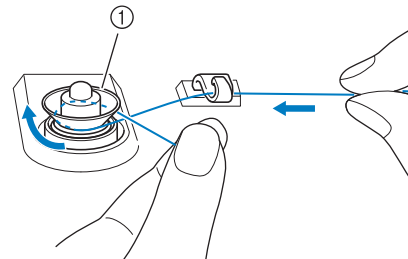

① Pre-tension disk
→ Make sure that the thread passes under the pre-tension disk.

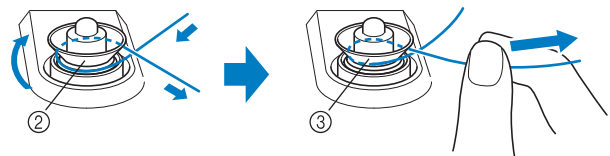

② Pre-tension disk
③ Pull it in as far as possible.
→ Check to make sure thread is securely set between pre-tension disks.

- 7** Wind the thread clockwise around the bobbin 5-6 times.

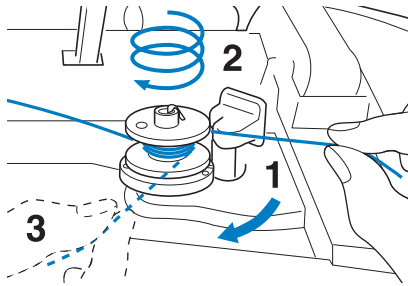

- 8** Pass the end of the thread through the guide slit in the bobbin winder seat, and pull the thread to the right to cut the thread with the cutter.

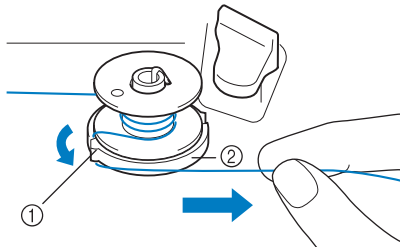

- ① Guide slit (with built-in cutter)
② Bobbin winder seat

CAUTION

- Be sure to follow the process described. If the thread is not cut with the cutter, and the bobbin is wound, when the thread runs low it may tangle around the bobbin and cause the needle to break.

- 9** Set the bobbin winding switch to the left, until it clicks into place.

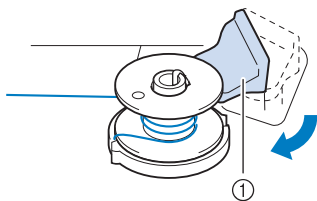

- ① Bobbin winding switch

Memo

- Sliding the bobbin winding switch to the left switches the machine into bobbin winding mode.

→ The bobbin winding window appears.

- 10** Press **START**.

→ Bobbin winding starts automatically. The bobbin stops rotating when bobbin winding is completed. The bobbin winding switch will automatically return to its original position.

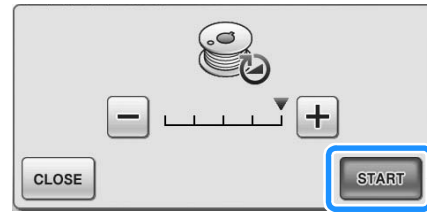



Note

- **START** changes to **STOP** while the bobbin is winding.
- Stay near the machine while winding the bobbin to make sure the bobbin thread is being wound correctly. If the bobbin thread is wound incorrectly, press **STOP** immediately to stop the bobbin winding.
- The sound of winding the bobbin with stiff thread, such as nylon thread for quilting, may be different from the one produced when winding normal thread; however, this is not a sign of a malfunction.

Memo

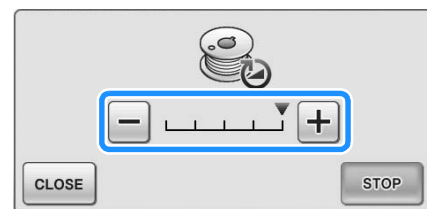
- You can change the winding speed by pressing **-** (to decrease) or **+** (to increase) in the bobbin winding window.



- Press **CLOSE** to minimize the bobbin winding window. Then, you can perform other operations, such as selecting a stitch or adjusting the thread tension, while the bobbin is being wound.
- Press  (in top right of the LCD screen) to display the bobbin winding window again.

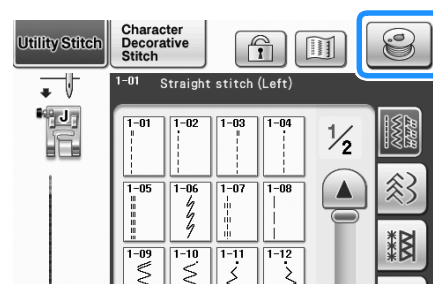

- 11 Cut the thread with cutter and remove the bobbin.

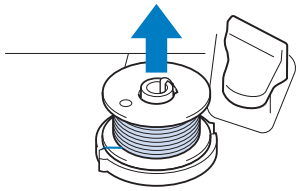

Memo

- When removing the bobbin, do not pull on the bobbin winder seat. Doing so could loosen or remove the bobbin winder seat, and could result in damage to the machine.

CAUTION

- Setting the bobbin improperly may cause the thread tension to loosen, breaking the needle and possibly resulting in injury.

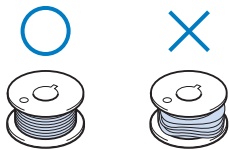

Using the Spool Pin

You can use the main spool pin to wind the bobbin before sewing. You cannot use this spool pin to wind the bobbin while sewing.

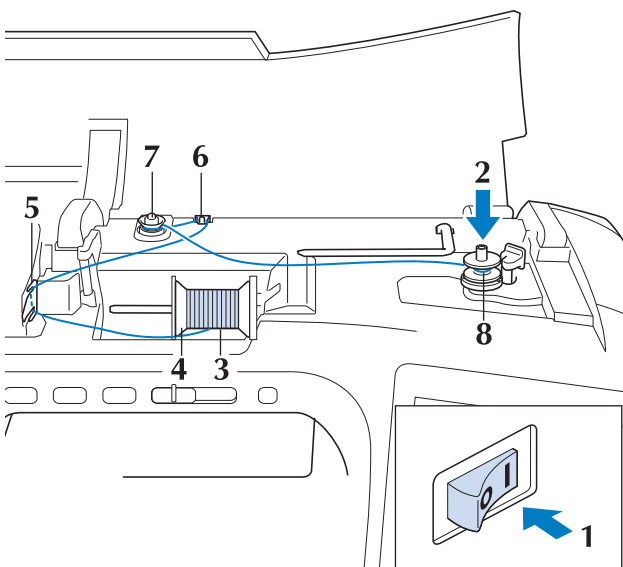

- 1 Turn the main power to ON and open the top cover.
- 2 Align the groove in the bobbin with the spring on the bobbin winder shaft, and set the bobbin on the shaft.

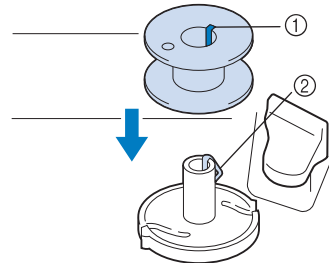

- ① Groove in the bobbin
- ② Spring on the shaft

- 3 Pivot the spool pin so that it angles upward. Set the thread spool on the spool pin so that the thread unwinds from the front of the spool.

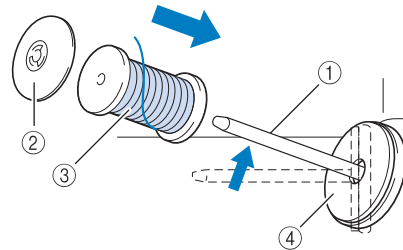

- ① Spool pin
- ② Spool cap
- ③ Thread spool
- ④ Spool felt

- 4 Push the spool cap onto the spool pin as far as possible, then return the spool pin to its original position.
- 5 While holding the thread with both hands, pull the thread up from under the thread guide plate.

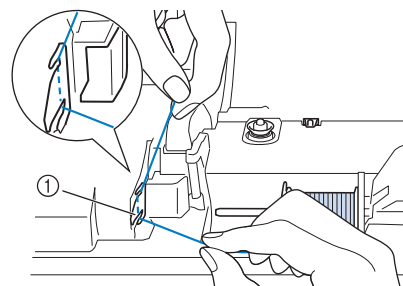

- ① Thread guide plate

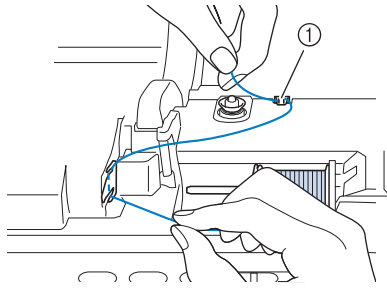
6 Pass the thread through the thread guide.

① Thread guide

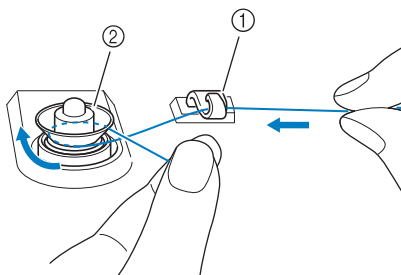
7 Pass the thread around the pre-tension disk making sure that the thread is under the pre-tension disk.① Thread guide
② Pre-tension disk**8** Follow steps 7 through 11 on page 39 through 40.**Using the Spool Stand**

To wind thread on the bobbin while the spool stand is installed, pass the thread from the spool through the thread guide on the telescopic thread guide, and then wind the bobbin according to steps 5 through 11 of "Using the Supplemental Spool Pin" on page 38 to page 40.

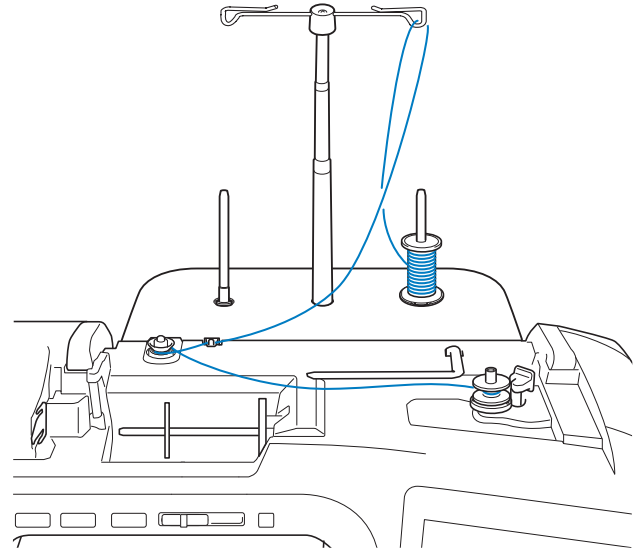
**Memo**

- See page 9 to assemble the spool stand.
- See page 52 to thread the machine using the spool stand.

CAUTION

- When winding thread on the bobbin, do not cross the bobbin winding thread with the upper thread in the thread guides.

■ Untangling Thread from Beneath the Bobbin Winder Seat

If the bobbin winding starts when the thread is not passed through the pre-tension disk correctly, the thread may become tangled beneath the bobbin winder seat.

Wind off the thread according to the following procedure.

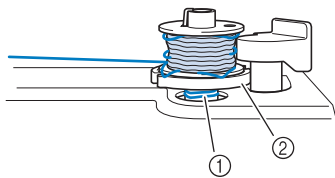

- ① Thread
- ② Bobbin winder seat

⚠ CAUTION

- Do not remove the bobbin winder seat even if the thread becomes tangled under the bobbin winder seat. It may result in injuries.

- 1 If the thread becomes tangled under the bobbin winder seat, press **STOP** once to stop the bobbin winding.

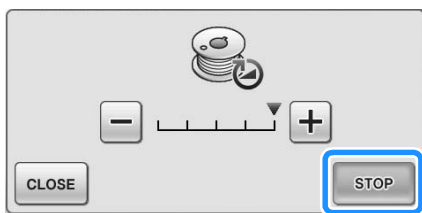

- 2 Cut the thread with scissors near the pre-tension disk.

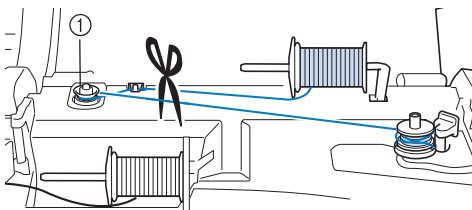

- ① Pre-tension disk

- 3 Push the bobbin winder switch to the right, and then raise the bobbin at least 10 cm (4 inches) from the shaft.

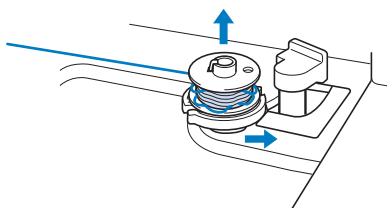

- 4 Cut the thread near the bobbin and hold the thread end with your left hand. Unwind the thread counter clockwise near the bobbin winder seat with your right hand as shown below.

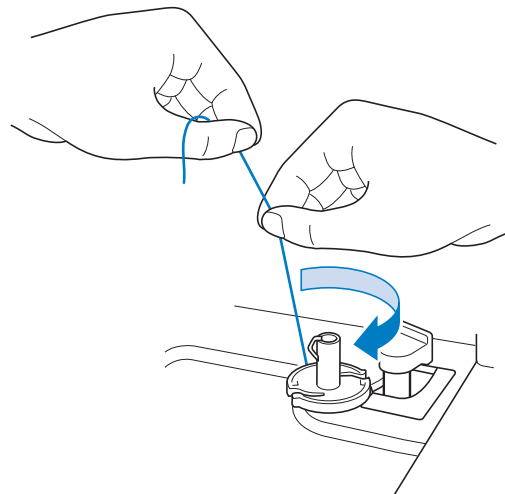

- 5 Wind the bobbin again.



Note

- Make sure that the thread passes through the pre-tension disk correctly (page 38).

Setting the Bobbin

Press **?** → **Operation Guide** → **Basic Operation** →



→ **Video** in this order to display a

video example of the operation on the LCD (see page 34). Follow the steps explained below to complete the operation.

CAUTION

- Use a bobbin thread that has been correctly wound. Otherwise, the needle may break or the thread tension will be incorrect.

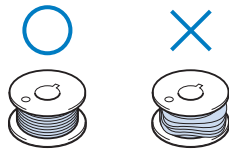

- The included bobbin was designed specifically for this sewing machine. If bobbins from other models are used, the machine will not operate correctly. Use only the included bobbin or bobbins of the same type (part code: SA156, (SFB: XA5539-151)).

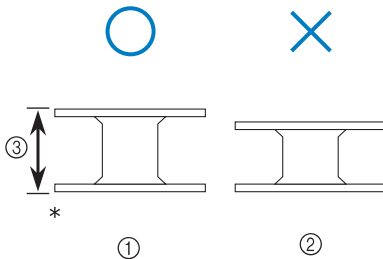

* Actual size

① This model

② Other models

③ 11.5 mm (approx. 7/16 inch)

- Before inserting or changing the bobbin, be sure to press **Start/Stop** in the LCD, otherwise injuries may occur if the "Start/Stop" button or any other button is pressed and the machine starts sewing.

1 Press **Start/Stop**.

2 Slide the bobbin cover latch to the right.

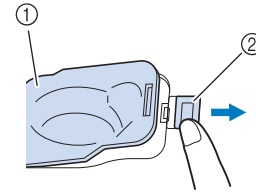

① Bobbin cover

② Latch

→ The bobbin cover opens.

3 Remove the bobbin cover.

4 Hold the bobbin with your right hand and hold the end of the thread with your left hand.

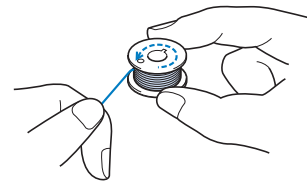

5 Set the bobbin in the bobbin case so that the thread unwinds to the left.

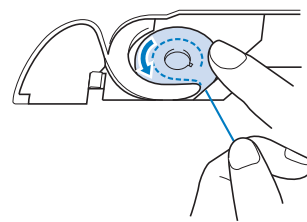

6 Hold the bobbin lightly with your right hand, and then guide the thread with your left hand.

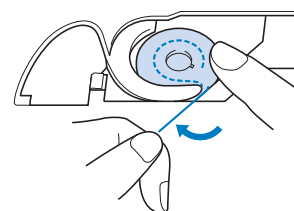

- 7** Pass the thread through the guide, and then pull the thread out toward the front.

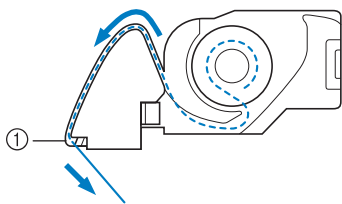

- ① Cutter
→ The cutter cuts the thread.

Note

- If the thread is not correctly inserted through the tension spring of the bobbin case, it may cause incorrect thread tension. (see page 67)

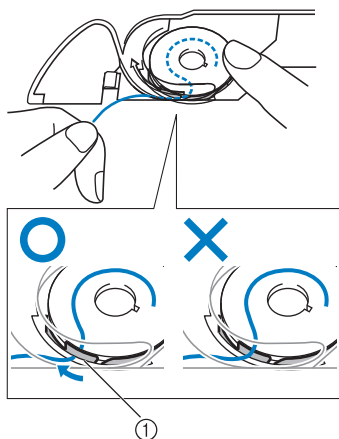

- ① Tension spring

- 8** Insert the tab in the lower-left corner of the bobbin cover (1), and then lightly press down on the right side to close the cover (2).

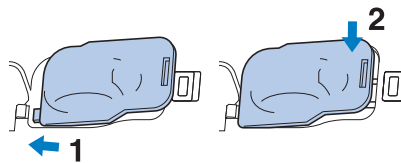

CAUTION

- Be sure to hold down the bobbin with your finger and unwind the bobbin thread correctly. Otherwise, the thread may break or the thread tension will be incorrect.

Pulling Up the Bobbin Thread

There may be some sewing applications where you want to pull up the bobbin thread; for example, when making gathers, darts, or doing free motion quilting or embroidery.

Memo

- You can pull up the bobbin thread after threading the upper thread ("UPPER THREADING" on page 46).

1 Guide the bobbin thread through the groove, following the arrow in the illustration.

- Do not cut the thread with the cutter.
- Do not replace the bobbin cover.

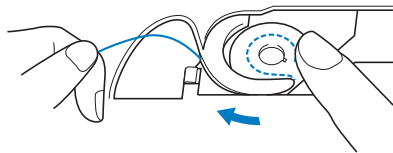

2 While holding the upper thread, press the "Needle Position" button to lower the needle.

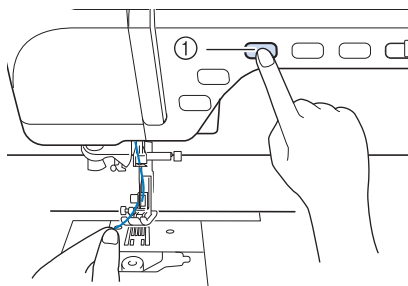

① "Needle Position" button

3 Press the "Needle Position" button to raise the needle.

4 Gently pull the upper thread. A loop of the bobbin thread will come out of the hole in the needle plate.

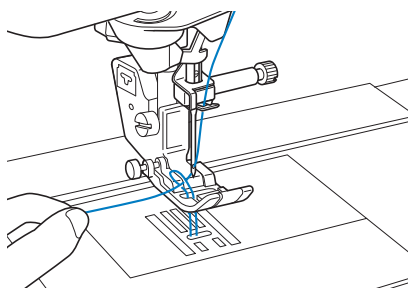

5 Pull up the bobbin thread, pass it under the presser foot and pull it about 100 mm (approx. 3-4 inches) toward the back of the machine, making it even with the upper thread.

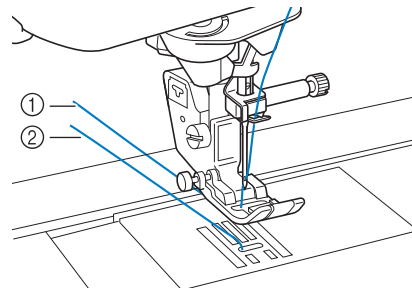

- ① Upper thread
- ② Bobbin thread

6 Replace the bobbin cover.

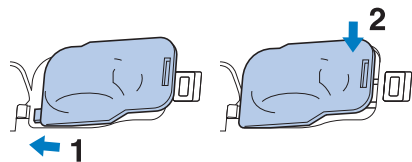

UPPER THREADING

Upper Threading

Press **?** → **Operation Guide** → **Basic Operation** →

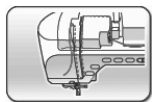

→  in this order to display a

video example of the operation on the LCD (see page 34). Follow the steps explained below to complete the operation.

CAUTION

- Be sure to thread the machine properly. Improper threading can cause the thread to tangle and break the needle, leading to injury.
- When using the walking foot, the side cutter or accessories not included with this machine, attach the accessory to the machine after threading the machine.

Memo

- The automatic threading function can be used with sewing machine needle sizes 75/11 through 100/16.
- Thread such as transparent nylon monofilament thread and thread with a thickness of 130/20 or thicker cannot be used with the automatic threading function.
- The automatic threading function cannot be used with the wing needle or the twin needle.

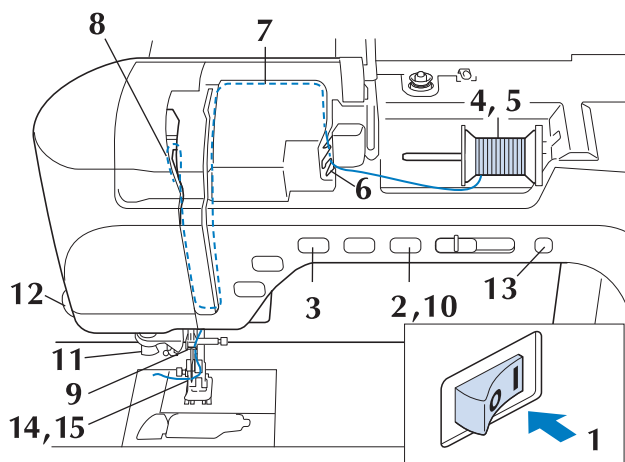

1 Turn the main power to ON.

2 Press the “Presser Foot Lifter” button to raise the presser foot.

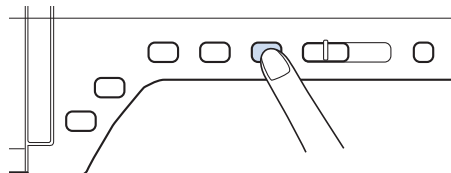

→ The upper thread shutter opens so the machine can be threaded.

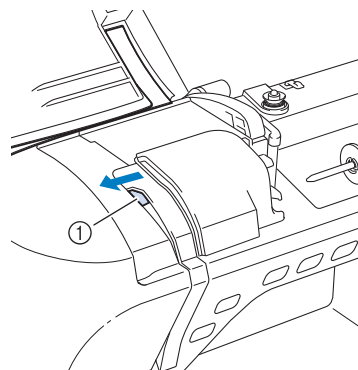

① Upper thread shutter

Memo

- This machine is equipped with an upper thread shutter, allowing you to check that the upper threading is performed correctly.

3 Press the “Needle Position” button to raise the needle.

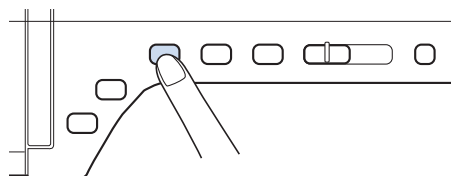

Note

- If you try to thread the needle automatically without raising the needle, the thread may not thread correctly.

- 4** Pivot the spool pin so that it angles upward. Set the thread spool on the spool pin so that the thread unwinds from the front of the spool.

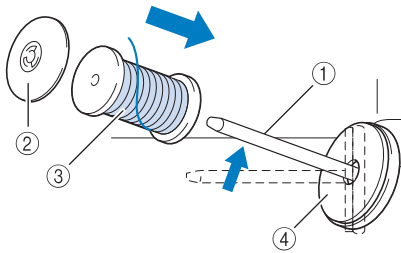

- ① Spool pin
- ② Spool cap
- ③ Thread spool
- ④ Spool felt

- 5** Push the spool cap onto the spool pin as far as possible, then return the spool pin to its original position.

CAUTION

- If the thread spool and/or spool cap are set incorrectly, the thread may tangle on the spool pin and cause the needle to break.
- Use the spool cap (large, medium, or small) that is closest in size to the thread spool. If a spool cap smaller than the thread spool is used, the thread may become caught in the slit on the end of the spool and cause the needle to break.

Memo

- When sewing with fine, cross-wound thread, use the small spool cap, and leave a small space between the cap and the thread spool.

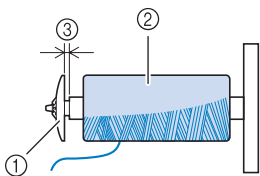

- ① Spool cap (small)
- ② Thread spool (cross-wound thread)
- ③ Space

- 6** While holding the thread with both hands, pull the thread up from under the thread guide plate.

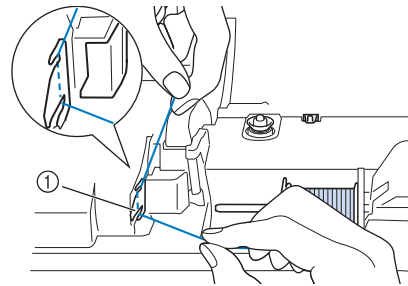

- ① Thread guide plate

- 7** While holding the thread in your right hand, pass the thread through the thread guide in the direction indicated.

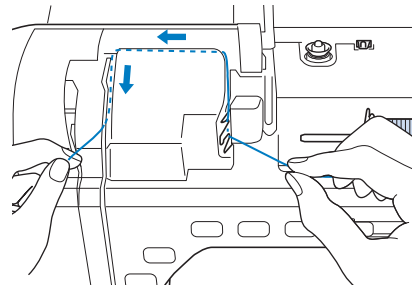

- 8** Guide the thread down, up, then down through the groove, as shown in the illustration.

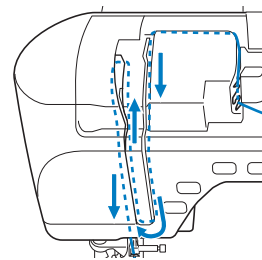

Memo

- Look in the upper groove area to check if the thread catches on the take-up lever visible inside the upper groove area.

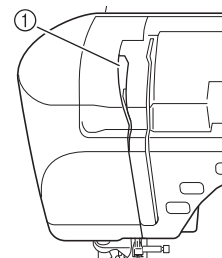

- ① Look in the upper groove area

- 9** Pass the thread through the needle bar thread guide (marked "6") by holding the thread with both hands and guiding it as shown in the illustration.

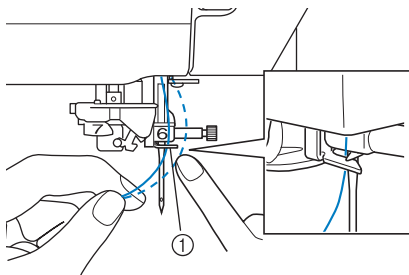

① Needle bar thread guide

- 10** Press the "Presser Foot Lifter" button to lower presser foot.

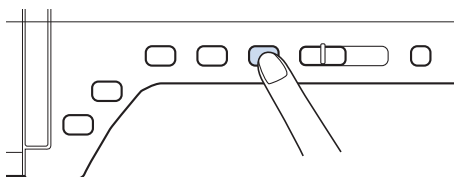

- 11** Pass the thread through the thread guide disks (marked "7"). Make sure that the thread passes through the groove in the thread guide.

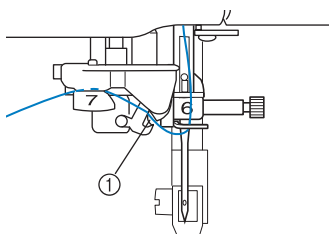

① Groove in thread guide

- 12** Pull the thread up through the thread cutter to cut the thread, as shown in the illustration.

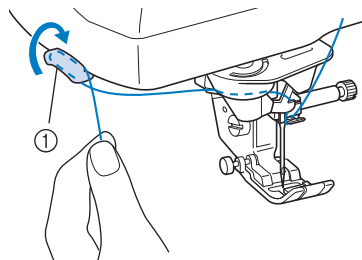

① Thread cutter



Note

- When using thread that quickly winds off the spool, such as metallic thread, it may be difficult to thread the needle if the thread is cut. Therefore, instead of using the thread cutter, pull out about 80 mm (approx. 3 inches) of thread after passing it through the thread guide disks (marked "7").

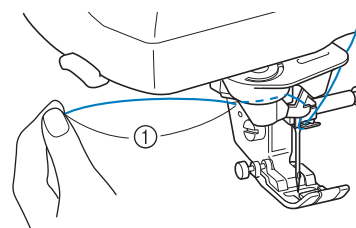

① 80 mm (approx. 3 inches) or more

- 13** Press the "Automatic Threading" button to have the machine automatically thread the needle.

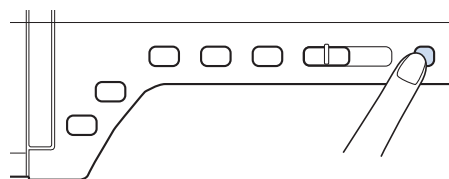

→ The thread passes through the eye of the needle.



Memo

- When the "Automatic Threading" button is pressed, the presser foot will be automatically lowered. After threading is finished, the presser foot moves back to the position before the "Automatic Threading" button was pressed.

14 Carefully pull the end of the thread that was passed through the eye of the needle.

- * If a loop was formed in the thread passed through the eye of the needle, carefully pull on the loop of thread through to the back of the needle.

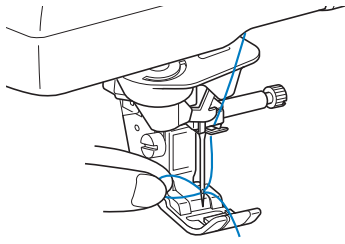

Note

- Pulling the loop of thread gently will avoid needle breakage.

15 Pull out about 10-15 cm (approx. 4-6 inches) of the thread, and then pass it under the presser foot toward the rear of the machine.

- Raise the presser foot lever if the presser foot is lowered.

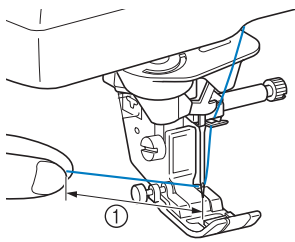

- ① About 10-15 cm (approx. 4-6 inches)



Memo

- If the needle could not be threaded or the thread was not passed through the needle bar thread guides, perform the procedure again starting from step ③. Then, pass the thread through the eye of the needle after step ⑨.



Note

- Some needles cannot be threaded with the needle threader. In this case, instead of using the needle threader after passing the thread through the needle bar thread guide (marked "6"), manually pass the thread through the eye of the needle from the front.

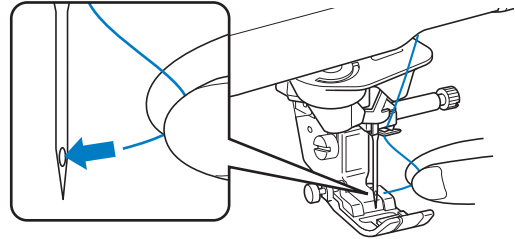



Using the Twin Needle Mode

The twin needle can only be used for patterns that show  after being selected. Before you select a stitch pattern, make sure the stitch can be sewn in the twin needle mode (refer to the "STITCH SETTING CHART" at the end of this manual).



CAUTION

- Twin needle (part code XE4963-001) is recommended for this machine. Contact your authorized dealer for replacement needles (size 2.0/11 is recommended).
- Be sure to set the twin needle mode when using the twin needle. Using the twin needle while the machine is in single needle mode could cause the needle to break, resulting in damage.
- Do not sew with bent needles. The needle could break and cause injury.
- When using the twin needle, it is recommended to use presser foot "J".
- When the twin needle is used, bunched stitches may occur depending on the types of fabric and thread that are used. Use monogramming foot "N" for decorative stitches.
- Before changing the needle or threading the machine, be sure to press  on the LCD Screen, otherwise injuries may occur if the "Start/Stop" button or any other button is pressed and the machine starts sewing.

- 1 Press  and install the twin needle ("CHANGING THE NEEDLE" on page 56).

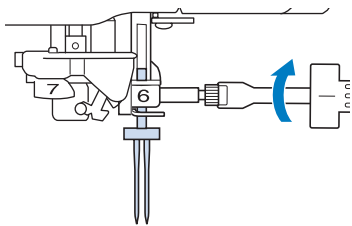

- 2 Thread the machine for the first needle according to the procedure for threading a single needle ("Upper Threading" on page 46).

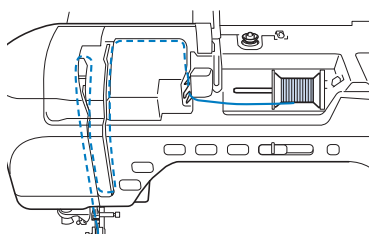

- 3 Pass the thread through the needle bar thread guides on the needle bar, then thread the needle on the left side manually.

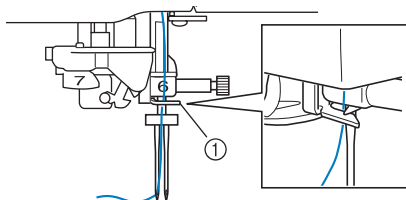

① Needle bar thread guide



Note

• The "Automatic Threading" button cannot be used. Manually thread the twin needle from front to back. Using the "Automatic Threading" button may result in damage to the machine.

- 4 Pull up the supplemental spool pin and set it in the up position.

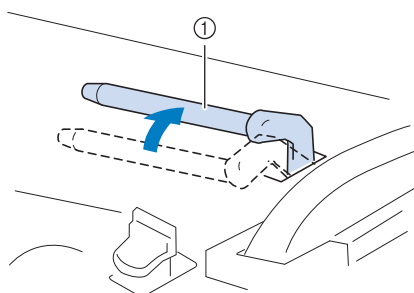

① Supplemental spool pin

- 5 Place the additional spool of thread on the supplemental spool pin, so that the thread unwinds from the front. Push the spool cap onto the spool pin as far as possible to secure the thread spool.

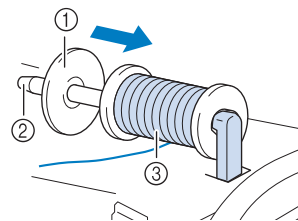

① Spool cap
② Spool pin
③ Thread spool

- 6 Hold the thread from the spool with both hands, and place the thread in the thread guide.

* Do not place the thread in the pre-tension disks.

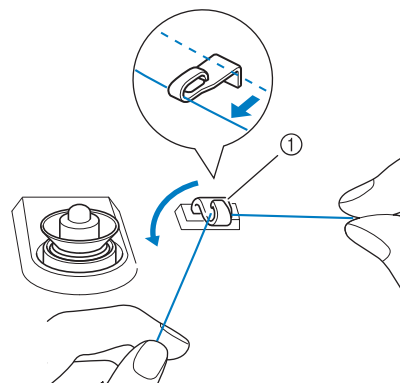

① Thread guide

- 7 While holding the thread from the spool, pull the thread through the lower notch in the thread guide plate, then through the upper notch. Hold the end of the thread with your left hand, and then guide the thread through the groove, following the arrows in the illustration.

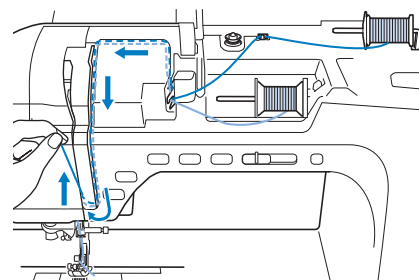

- 8 Continue threading however do not pass the thread in the needle bar thread guide "6" on the needle bar. Thread the needle on the right side.

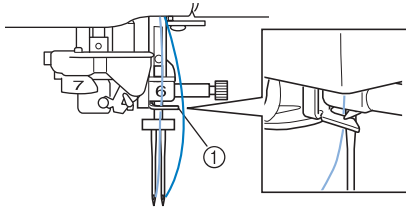

① Needle bar thread guide

- 9 Press .

- 10 Select a stitch pattern. (Example: )

- * Refer to the "STITCH SETTING CHART" at the end of this manual for the proper stitch to use with presser foot "J".
- The selected stitch is displayed.

Note

- If the  key is light gray after selecting the stitch, the selected stitch cannot be sewn in the twin needle mode.

- 11 Press  to select the twin needle mode.

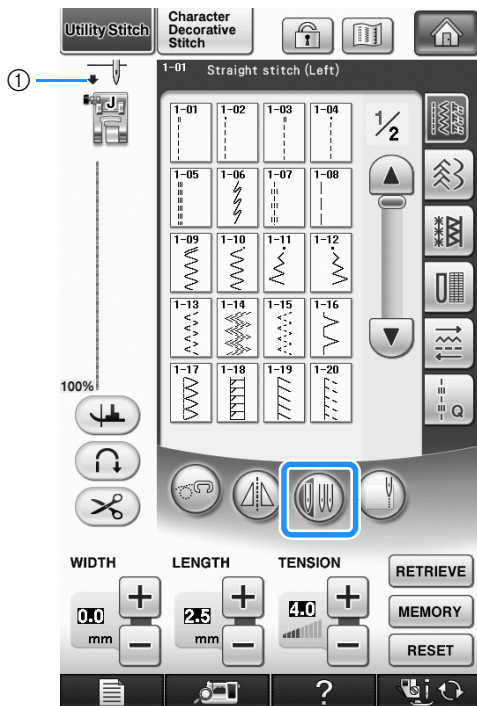

① Single needle/twin needle setting

-  appears.

CAUTION

- Be sure to set the twin needle mode when using the twin needle. Using the twin needle while the machine is in single needle mode could cause the needle to break, resulting in damage.

- 12 Start sewing.

Sample of Twin Needle Sewing

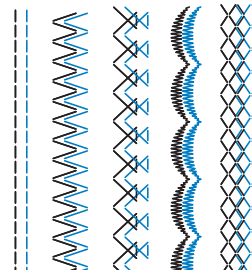

Memo

- To change direction when sewing with the twin needle, raise the needle from the fabric, raise the presser foot lever, and then turn the fabric.

Using the Spool Stand

The included spool stand is useful when using thread on spools with a large diameter (cross-wound thread). This spool stand can hold two spools of thread.

Memo

- See page 9 to assemble the spool stand.
- See page 41 to wind the bobbin when using the spool stand.

Using the Spool Stand

- Be sure to use a spool cap that is slightly larger than the spool.
If the spool cap that is used is smaller or much larger than the spool, the thread may catch and sewing performance may suffer.

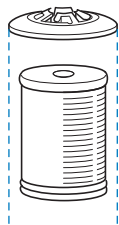

- When using thread on a thin spool, place the included spool felt on the spool pin, place the thread spool on the spool pin so that the center of the spool is aligned with the hole at the center of the spool felt, and then insert the spool cap onto the spool pin.

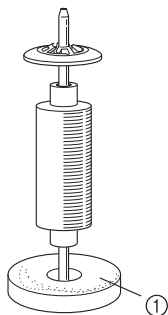

① Spool felt

- When using thread on a cone spool, use the spool holder.

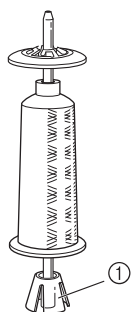

① Spool holder

- Depending on the size of spool or the amount of thread remaining, choose the appropriate sized spool cap (large or medium). Spool cap (small) cannot be used with the spool cap base.

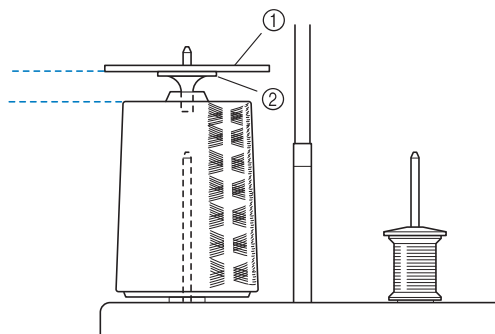

- ① Spool cap
- ② Spool cap base

1 Attach the spool stand to the machine. (see page 9.)

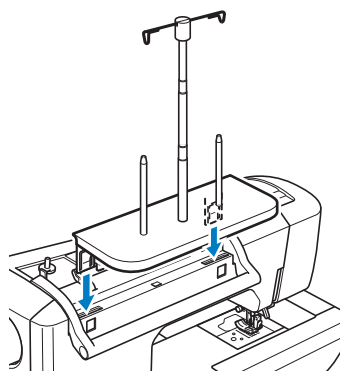

2 Place the spool of thread on the spool pin so that the thread feeds off the spool clockwise. Firmly insert the spool cap onto the spool pin.

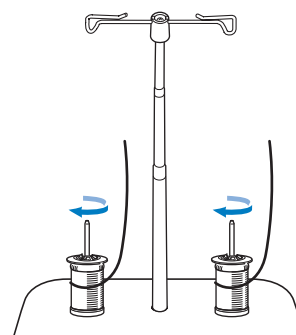

**Note**

- When using 2 spools of thread, make sure that both spools are feeding in the same direction.
- Make sure that the spools do not touch each other, otherwise the thread will not feed off smoothly, the needle may break, or the thread may break or become tangled. In addition, make sure that the spools do not touch the telescopic thread guide at the center.
- Make sure that the thread is not caught under the spool.

- 3** Pull the thread off the spool. Pass the thread from the back to the front through the thread guides at the top.

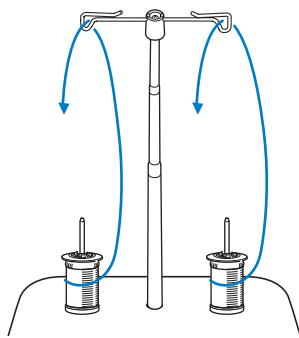
**Note**

- Guide the thread so that it does not become entangled with the other thread.
- After feeding the thread as instructed, wind any excess thread back onto the spool, otherwise the excess thread will become tangled.

- 4** Pass the thread through the machine's thread guide from the right to the left.

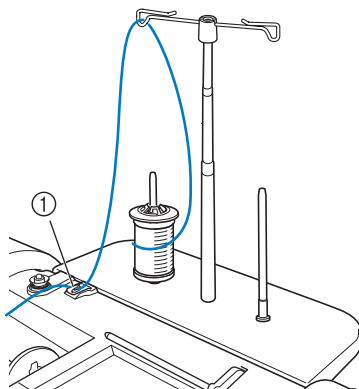

① Thread guide

- 5** Thread the machine according to the steps **6** to **15** of "Upper Threading" on page 46.

Using Threads that Unwind Quickly

■ Using the Spool Net

If using transparent nylon monofilament thread, metallic thread, or other strong thread, place the included spool net over the spool before using it. When using specialty threads, threading must be done manually.

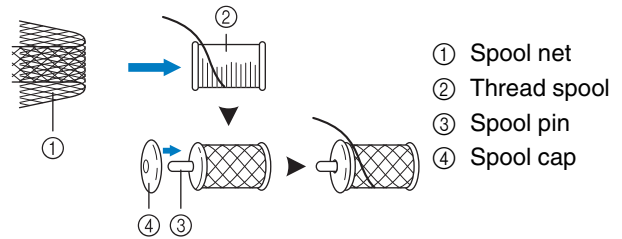

If the spool net is too long, fold it once to match it to the spool size before placing it over the spool.

**Memo**

- When threading the spool with the spool net on, make sure that 5-6 cm (approx. 2 - 2-1/2 inches) of thread are pulled out.
- It may be necessary to adjust the thread tension when using the spool net.

CHANGING THE PRESSER FOOT

⚠ CAUTION

- Always press  on the screen before changing the presser foot. If  is not pressed and the “Start/Stop” button or another button is pressed, the machine will start and may cause injury.
- Always use the correct presser foot for the selected stitch pattern. If the wrong presser foot is used, the needle may strike the presser foot and bend or break, and may cause injury.
- Only use presser feet made for this machine. Using other presser feet may lead to accident or injury.

Removing the Presser Foot

Press  →  →  →



in this order to display a video example of the operation on the LCD (see page 34). Follow the steps explained below to complete the operation.

- 1 Press the “Needle Position” button to raise the needle.

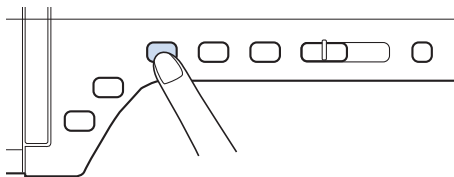

- 2 Press .

- * If the message “OK to automatically lower the presser foot?” appears on the LCD screen, press OK to continue.
- The entire screen becomes white, and all keys and operation buttons are locked.

- 3 Raise the presser foot lever.

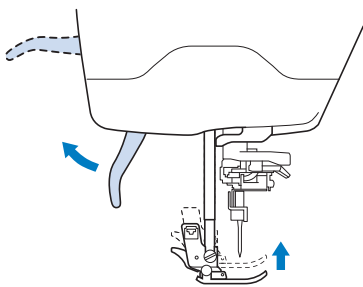

- 4 Press the black button on the presser foot holder and remove the presser foot.

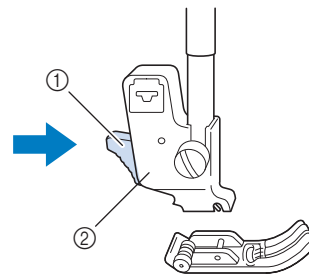

- ① Black button
- ② Presser foot holder

Attaching the Presser Foot

⚠ CAUTION

- Make sure that the presser foot is installed in the correct direction, otherwise the needle may strike the presser foot, breaking the needle and causing injuries.

- 1 Place the new presser foot under the holder, aligning the foot pin with the notch in the holder. Lower the presser foot lever so that the presser foot pin snaps into the notch in the holder.

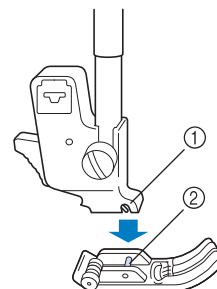

- ① Notch
- ② Pin

2 Press  to unlock all keys and buttons.

3 Raise the presser foot lever.

Attaching the Walking Foot

The walking foot holds the fabric between the presser foot and the feed dogs to feed the fabric. This enables you to have better fabric control when sewing difficult fabrics (such as quilted fabrics or velvet) or fabrics that slip easily (such as vinyl, leather, or synthetic leather).



Note

- Thread the needle manually when using the walking foot, or only attach the walking foot after threading the needle using the “Automatic Threading” button.
- When sewing with the walking foot, sew at medium to low speeds.



Memo

- The walking foot can only be used with straight or zigzag stitch patterns. Reverse stitches cannot be sewn with the walking foot. Only select straight or zigzag stitch patterns with reinforcement stitches. (see page 62.)

1 Follow the steps in “Removing the Presser Foot” on the previous page.

2 Loosen the screw of the presser foot holder to remove the presser foot holder.

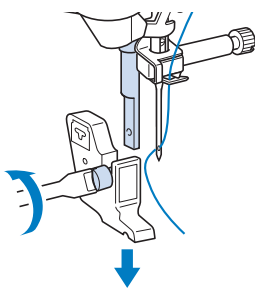

3 Set the operation lever of the walking foot so that the needle clamp screw is set between the fork. Position the shank of the walking foot on the presser foot bar.

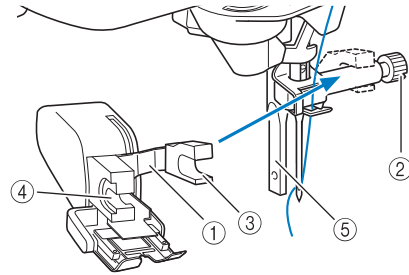

- ① Operation lever
- ② Needle clamp screw
- ③ Fork
- ④ Walking foot shank
- ⑤ Presser foot bar

4 Lower the presser foot lever. Insert the screw, and tighten the screw securely with the screwdriver.

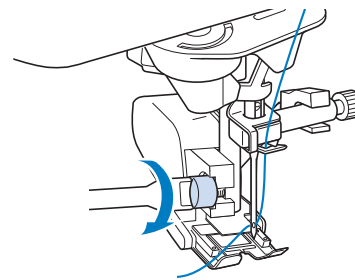



⚠ CAUTION

- Use the included screwdriver to tighten the screw securely. If the screw is loose, the needle may strike the presser foot and cause injury.
- Be sure to rotate the handwheel toward you (counterclockwise) to check that the needle does not strike the presser foot. If the needle strikes the presser foot, injury may result.

CHANGING THE NEEDLE

⚠ CAUTION

- Always press  on the screen before changing the needle. If  is not pressed and the Start/Stop button or another operation button is pressed accidentally, the machine will start and injury may result.
- Use only sewing machine needles made for home use. Other needles may bend or break and may cause injury.
- Never sew with a bent needle. A bent needle will easily break and may cause injury.

Press  →  →  →

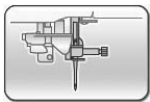

→  in this order to display a

video example of the operation on the LCD (see page 34). Follow the steps explained below to complete the operation.

Memo

- To check the needle correctly, place the flat side of the needle on a flat surface. Check the needle from the top and the sides. Throw away any bent needles.

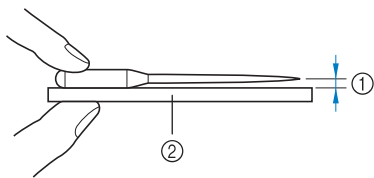

- ① Parallel space
- ② Level surface (bobbin cover, glass, etc.)

1 Press the “Needle Position” button to raise the needle.

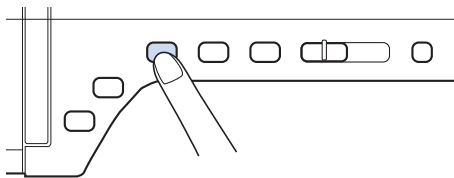

2 Press .

- * If the message “OK to automatically lower the presser foot?” appears on the LCD screen, press OK to continue.

→ The entire screen becomes white, and all keys and operation buttons are locked.

Note

- Before replacing the needle, cover the hole in the needle plate with fabric or paper to prevent the needle from falling into the machine.

3 Use the screwdriver to turn the screw toward the front of the machine and loosen the screw. Remove the needle.

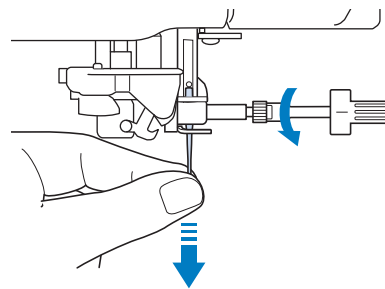

Note

- Do not apply pressure to the needle clamp screw. Doing so may damage the needle or machine.

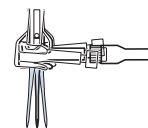

- 4** With the flat side of the needle facing the back, insert the new needle all the way to the top of the needle stopper (viewing window) in the needle clamp. Use a screwdriver to securely tighten the needle clamp screw.

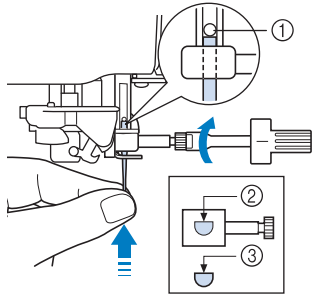

- ① Needle stopper
- ② Hole for setting the needle
- ③ Flat side of needle

! CAUTION

- Be sure to push in the needle until it touches the stopper, and securely tighten the needle clamp screw with a screwdriver. If the needle is not completely inserted or the needle clamp screw is loose, the needle may break or the machine may be damaged.

- 5** Press  to unlock all keys and buttons.

About the Needle

The sewing machine needle is probably the most important part of the sewing machine. Choosing the proper needle for your sewing project will result in a beautiful finish and fewer problems. Below are some things to keep in mind about needles.

- The smaller the needle number, the finer the needle. As the numbers increase, the needles get thicker.
- Use fine needles with lightweight fabrics, and thicker needles with heavyweight fabrics.
- To avoid skipped stitches, use ball point needle (golden colored) 90/14 with stretch fabrics.
- To avoid skipped stitches, use ball point needle (golden colored) 90/14 when sewing character or decorative stitches.
- Use needle 75/11 for embroidery. Use ball point needle 75/11 for embroidering patterns with short jump stitches such as alphabet characters when the thread trimming function is turned on.
- Ball point needles (golden colored) 90/14 are not recommended for embroidery, as they may bend or break, causing injury.
- It is recommended that a 90/14 needle should be used when embroidering on heavyweight fabrics or stabilizing products (for example, denim, puffy foam, etc.). A 75/11 needle may bend or break, which could result in injury.
- A home sewing machine needle 75/11 is inserted in the sewing machine.

Fabric/Thread/Needle Combinations

The following table provides information concerning the appropriate thread and needle for various fabrics. Please refer to this table when selecting a thread and needle for the fabric you wish to use.

Fabric type/Application		Thread		Size of needle
		Type	Size	
Medium weight fabrics	Broadcloth	Cotton thread	60 - 90	75/11 - 90/14
	Taffeta	Synthetic thread		
	Flannel, Gabardine	Silk thread	50	
Thin fabrics	Lawn	Cotton thread	60 - 90	65/9 - 75/11
	Georgette	Synthetic thread		
	Challis, Satin	Silk thread	50	
Thick fabrics	Denim	Cotton thread	30	90/14 - 100/16
			50	
	Corduroy	Synthetic thread	50 - 60	
	Tweed	Silk thread		
Stretch fabrics	Jersey	Thread for knits	50 - 60	Ball point needle (gold colored) 75/11 - 90/14
	Tricot			
Easily frayed fabrics	Cotton thread		50 - 90	65/9 - 90/14
	Synthetic thread			
	Silk thread		50	
For top-stitching	Synthetic thread		50	90/14 - 100/16
	Silk thread			



Memo

- For transparent monofilament nylon thread, always use needle sizes 90/14 or 100/16. The same thread is usually used for the bobbin thread and upper thread.

CAUTION

- Be sure to follow the needle, thread, and fabric combinations listed in the table. Using an improper combination, especially a heavyweight fabric (i.e., denim) with a small needle (i.e., 65/9 - 75/11), may cause the needle to bend or break, and lead to injury. Also, the seam may be uneven, the fabric may pucker, or the machine may skip stitches.



Chapter 2

Sewing Basics

SEWING	60
Sewing a Stitch.....	60
■ Using the Foot Controller.....	61
Sewing Reinforcement Stitches	62
Sewing Curves.....	62
Changing Sewing Direction.....	63
■ Sewing a Seam Allowance of 0.5 cm or Less	63
Sewing Heavyweight Fabrics.....	63
■ If the Fabric does not Fit under the Presser Foot.....	63
■ If the Fabric does not Feed	64
Sewing Hook-and-Loop Fastener	64
Sewing Lightweight Fabrics	64
Sewing Stretch Fabrics	65
STITCH SETTINGS	66
Setting the Stitch Width	66
Setting the Stitch Length	67
Setting the Thread Tension.....	67
■ Proper Thread Tension	67
■ Upper Thread is Too Tight.....	68
■ Upper Thread is Too Loose.....	68
USEFUL FUNCTIONS	69
Automatic Reinforcement Stitching	69
Automatic Thread Cutting.....	70
Using the Knee Lifter.....	71
Pivoting.....	72
Automatic Fabric Sensor System (Automatic Presser Foot Pressure)	73
Needle Position – Stitch Placement.....	74
Locking the Screen	74
Checking the Needle Location in the Screen.....	75

SEWING

! CAUTION

- To avoid injury, pay special attention to the needle while the machine is in operation. Keep your hands away from moving parts while the machine is in operation.
- Do not stretch or pull the fabric during sewing. Doing so may lead to injury.
- Do not use bent or broken needles. Doing so may lead to injury.
- Do not attempt to sew over basting pins or other objects during sewing. Otherwise, the needle may break and cause injury.
- If stitches become bunched, lengthen the stitch length setting before continuing sewing. Otherwise, the needle may break and cause injury.

Sewing a Stitch

- 1 Turn the main power to ON and press



to display the utility stitches, and push the “Needle Position” button to raise the needle.

- 2 Press the key of the stitch you want to sew.

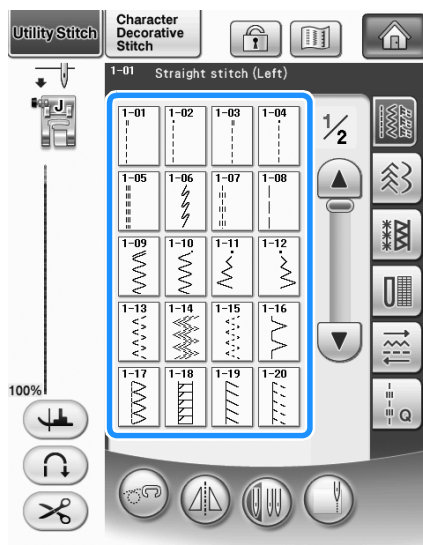

→ The symbol of the correct presser foot will be displayed in the upper left corner of the LCD screen.

- 3 Install the presser foot (“CHANGING THE PRESSER FOOT” on page 54).

! CAUTION

- Always use the correct presser foot. If the wrong presser foot is used, the needle may strike the presser foot and bend or break, possibly resulting in injury. Refer to page 347 for presser foot recommendations.

- 4 Set the fabric under the presser foot. Hold the fabric and thread in your left hand, and rotate the handwheel to set the needle in the sewing start position.

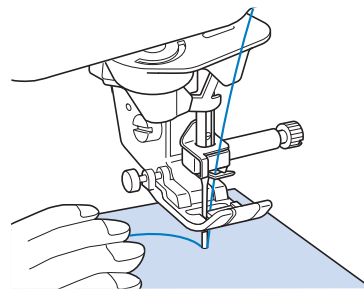

Memo

- The black button on the left side of presser foot “J” should be pressed only if the fabric does not feed or when sewing thick seams (see page 64). Normally, you can sew without pressing the black button.

- 5 Lower the presser foot.

* You do not have to pull up the bobbin thread.

6 Adjust the sewing speed with the speed control slide.

- * You can use this slide to adjust sewing speed during sewing.

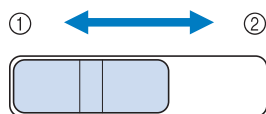

- ① Slow
- ② Fast

7 Press the "Start/Stop" button to start sewing.

- * Guide the fabric lightly by hand.

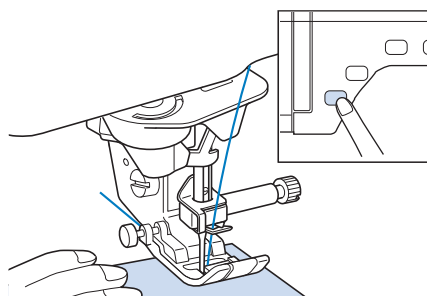

Memo

- When the foot controller is being used, you cannot start sewing by pressing the "Start/Stop" button.

8 Press the "Start/Stop" button again to stop sewing.

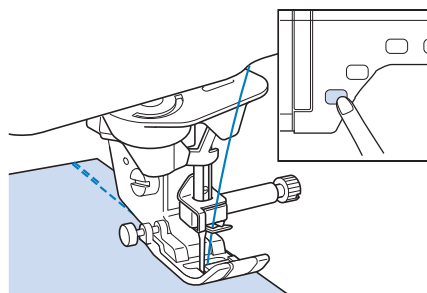

9 Press the "Thread Cutter" button to trim the upper and lower threads.

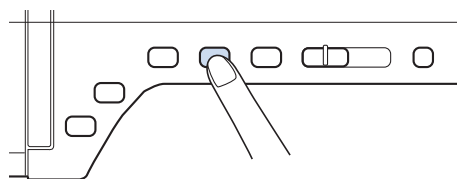

- The needle will return to the up position automatically.

CAUTION

- Do not press the "Thread Cutter" button after the threads have been cut. Doing so could tangle the thread or break the needle and damage the machine.
- Do not press the "Thread Cutter" button when there is no fabric set in the machine or during machine operation. The thread may tangle, possibly resulting in damage.

Note

- When cutting thread thicker than #30, nylon monofilament thread, or other decorative threads, use the thread cutter on the side of the machine.

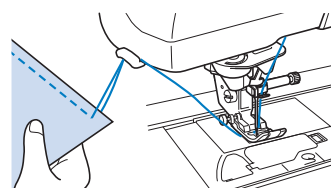

10 When the needle has stopped moving, raise the presser foot and remove the fabric.

Memo

- This machine is equipped with a bobbin thread sensor that warns you when the bobbin thread is almost empty. When the bobbin thread is nearly empty, the machine automatically stops. However, if the "Start/Stop" button is pressed, a few stitches can be sewn. When the warning displays, re-thread the machine immediately.

Using the Foot Controller

You can also use the foot controller to start and stop sewing.

CAUTION

- Do not allow fabric pieces and dust to collect in the foot controller. Doing so could cause a fire or an electric shock.

Memo

- When the foot controller is being used, you cannot start sewing by pressing the "Start/Stop" button.
- The foot controller cannot be used when embroidering.
- The foot controller can be used for sewing utility and decorative stitches when the embroidery unit is attached.

- 1 Pull the retractable cord out from the foot controller to the desired length, and then insert the foot controller plug into its jack on the machine.**

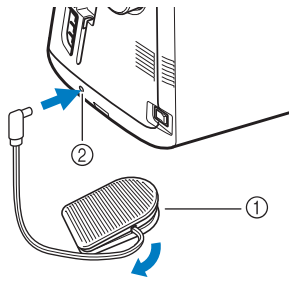

- ① Foot controller
- ② Foot controller jack



Note

- Do not pull the retractable cord out beyond the red mark on the cord.

- 2 Slowly depress the foot controller to start sewing.**

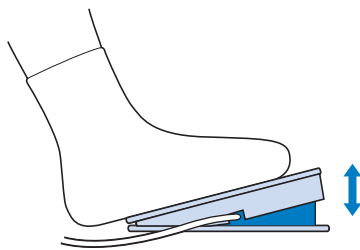

Memo

- The speed that is set using the sewing speed controller is the foot controller's maximum sewing speed.

- 3 Release the foot controller to stop the machine.**

Sewing Reinforcement Stitches

Reverse/reinforcement stitches are generally necessary at the beginning and end of sewing. You can use the "Reverse/Reinforcement Stitch" button to sew reverse/reinforcement stitches manually (see page 3).

If the automatic reinforcement stitch is selected on the screen, reverse stitches (or reinforcement stitches) will be sewn automatically at the beginning of sewing when the "Start/Stop" button is pressed. Press the "Reverse/Reinforcement Stitch" button to sew reverse stitches (or reinforcement stitches) automatically at the end of sewing (see page 69).

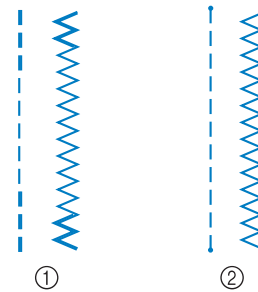

- ① Reverse stitch
- ② Reinforcement stitch

If the stitch which you select has a double mark "⌘" at the top of the key display, you can sew reverse stitches by holding the "Reverse/Reinforcement Stitch" button.

If the stitch which you select has a dot mark "•" at the top of the key display, you can sew reinforcement stitches by holding the "Reverse/Reinforcement Stitch" button.

Sewing Curves

Sew slowly while keeping the seam parallel with the fabric edge as you guide the fabric around the curve.

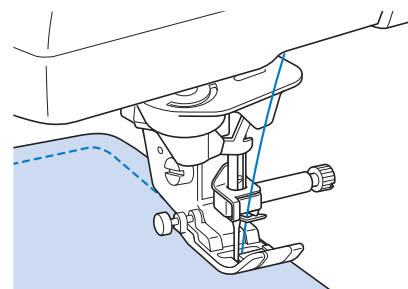

Changing Sewing Direction

Stop the machine. Leave the needle in the fabric, and press the “Presser Foot Lifter” button to raise the presser foot. Using the needle as a pivot, turn the fabric so that you can sew in the new direction. Press the “Presser Foot Lifter” button to lower the presser foot and start sewing.

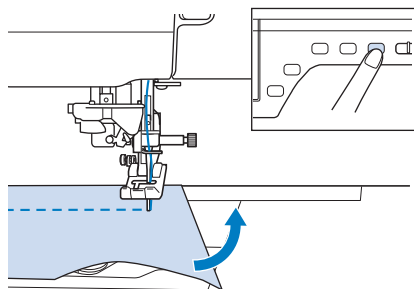

The pivot setting is useful when changing the sewing direction. When the machine is stopped at the corner of the fabric, the machine stops with the needle in the fabric and the presser foot is automatically raised so the fabric can easily be rotated (“Pivoting” on page 72).

■ Sewing a Seam Allowance of 0.5 cm or Less

Baste the corner before sewing, and then, after changing the sewing direction at the corner, pull the basting thread toward the back while sewing.

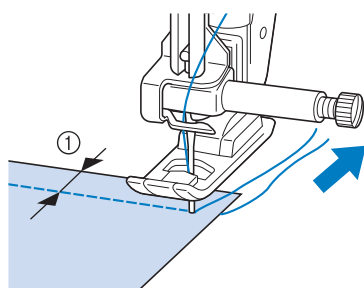

① 5 mm (approx. 3/16 inch)

Sewing Heavyweight Fabrics

The sewing machine can sew fabrics up to 6 mm (approx. 1/4 inch) thick. If the thickness of a seam causes sewing to occur at an angle, help guide the fabric by hand and sew on the downward slope.

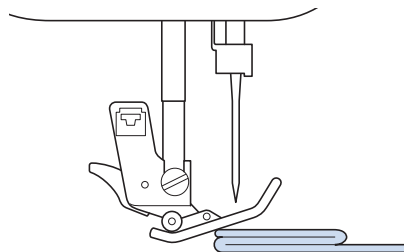

⚠ CAUTION

- Do not forcefully push fabrics more than 6 mm (approx. 1/4 inch) thick through the sewing machine. This may cause the needle to break and cause injury.
- Thicker fabrics require a larger needle (“CHANGING THE NEEDLE” on page 56).

■ If the Fabric does not Fit under the Presser Foot

If the presser foot is in the up position, and you are sewing heavyweight or multiple layers of fabric which do not fit easily under the presser foot, use the presser foot lever to raise the presser foot to its highest position. The fabric will now fit under the presser foot.

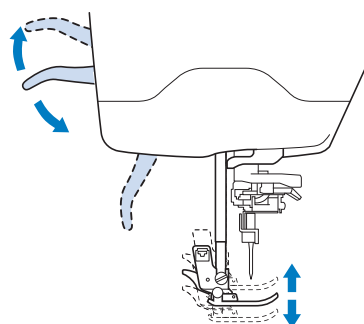

📖 Memo

- You cannot use the presser foot lever after the presser foot has been raised using the “Presser Foot Lifter” button.

■ If the Fabric does not Feed

If the fabric does not feed when starting to sew or when sewing thick seams, press the black button on the left side of presser foot “J”.

- 1 Raise the presser foot.
- 2 While keeping the black button on the left side of presser foot “J” pressed in, press the “Presser Foot Lifter” button to lower the presser foot.

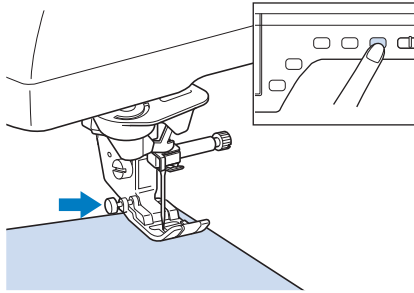

- 3 Release the black button.

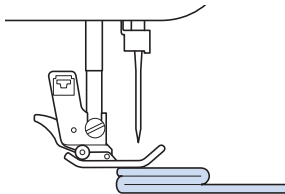

→ The presser foot remains level, enabling the fabric to be fed.



Memo

- Once the trouble spot has been passed, the foot will return to its normal position.
- When “Automatic Fabric Sensor System” (Automatic Presser Foot Pressure) in the machine settings screen is set to “ON”, the thickness of the fabric is automatically detected by the internal sensor so the fabric can be fed smoothly for best sewing results. (see page 73 for details.)

Sewing Hook-and-Loop Fastener

⚠ CAUTION

- Do not use adhesive backed hook-and-loop fastener designed for sewing. If the adhesive sticks to the needle or the bobbin hook race, it may cause malfunction.
- If the hook-and-loop fastener is sewn with a fine needle (65/9-75/11), the needle may bend or break.



Note

- Before starting to sew, baste the fabric and hook-and-loop fastener together.

Make sure that the needle passes through the hook-and-loop fastener by rotating the handwheel and lower the needle into the hook-and-loop fastener before sewing. Sew the edge of the hook-and-loop fastener at a slow speed.

If the needle does not pass through the hook-and-loop fastener, replace the needle with the needle for thick fabrics (page 58).

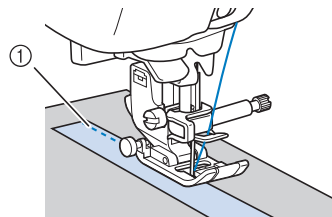

① Edge of the hook-and-loop fastener

Sewing Lightweight Fabrics

Place thin paper or tear away embroidery stabilizer under thin fabrics to make sewing easier. Gently tear off the paper or the stabilizer after sewing.

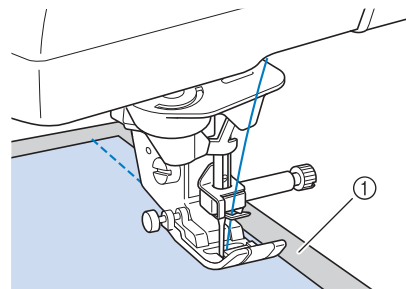

① Thin paper

Sewing Stretch Fabrics

First, baste together the pieces of fabric, and then sew without stretching the fabric.

In addition, a better result can be achieved by using thread for knits or a stretch stitch.



Memo

- For best results when sewing stretch fabrics, decrease the pressure of the presser foot (“Using the Machine Setting Mode Key” on page 22).

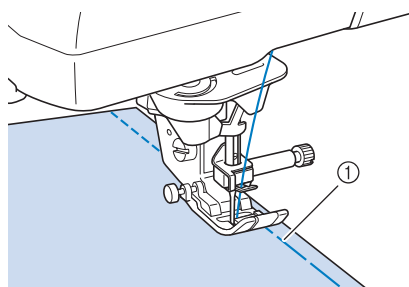

① Basting stitching

STITCH SETTINGS

When you select a stitch, your machine automatically selects the appropriate stitch width, stitch length, and upper thread tension. However, if needed, you can change any of the individual settings.



Note

- Settings for some stitches cannot be changed (refer to the “STITCH SETTING CHART” at the end of this manual).
- If you turn off the machine or select another stitch without saving stitch setting changes (“Saving Your Stitch Settings” on page 81), the stitch settings will return to their default settings.

Setting the Stitch Width

Follow the steps below when you want to change the zigzag stitch pattern width.

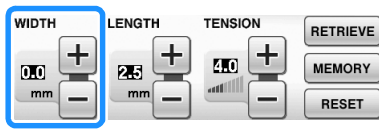

Memo

- For an alternate method of changing the stitch width using the speed controller, see page 104.

Example:

Press **-** to narrow the zigzag stitch pattern width.

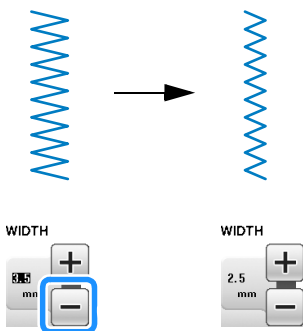

→ The value in the display gets smaller.

Press **+** to widen the zigzag stitch pattern width.

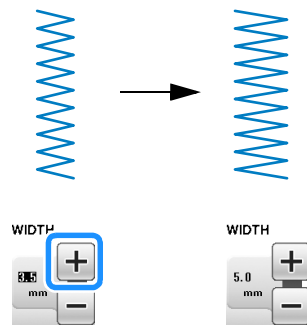

→ The value in the display gets bigger.



Memo

- Press **RESET** to return the stitch width to the original setting.



Note

- After adjusting the stitch width, slowly rotate the handwheel toward you (counterclockwise) and check that the needle does not touch the presser foot. If the needle hits the presser foot, the needle may bend or break.

Setting the Stitch Length

Follow the steps below when you want to change the stitch pattern length.

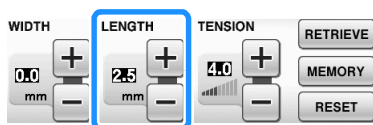

Example:

Press **-** to shorten the stitch length.

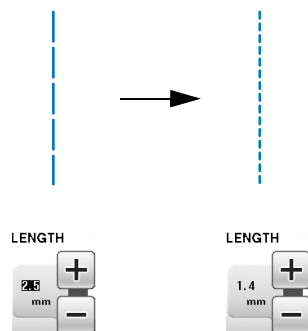

→ The value in the display gets smaller.

Press **+** to lengthen the stitch length.

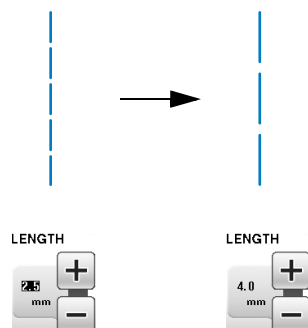

→ The value in the display gets bigger.

Memo

- Press **RETRIEVE** to check changes made to the stitch.
- Press **RESET** to return the stitch length to the original setting.

CAUTION

- If the stitches get bunched together, lengthen the stitch length and continue sewing. Do not continue sewing without lengthening the stitch length. Otherwise, the needle may break and cause injury.

Setting the Thread Tension

You may need to change the thread tension, depending on the fabric and thread being used. Follow the steps below to make any necessary changes.



Proper Thread Tension

The upper thread and the bobbin thread should cross near the center of the fabric. Only the upper thread should be visible from the right side of the fabric, and only the bobbin thread should be visible from the wrong side of the fabric.

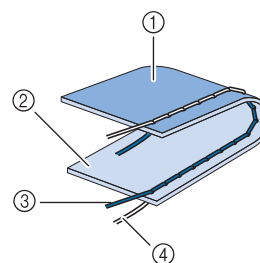

- ① Wrong side
- ② Surface
- ③ Upper thread
- ④ Bobbin thread

■ Upper Thread is Too Tight

If the bobbin thread is visible from the right side of the fabric, the upper thread is too tight.



Note

- If the bobbin thread was incorrectly threaded, the upper thread may be too tight. In this case, refer to “Setting the Bobbin” (page 43) and rethread the bobbin thread.

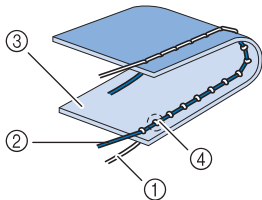

- ① Bobbin thread
- ② Upper thread
- ③ Surface
- ④ Locks appear on surface of fabric

Press  , to loosen the upper thread.



Memo

- When you finish sewing, remove the bobbin cover and then make sure that the thread is shown as below. If the thread is not shown as below, the thread is not inserted through the tension-adjusting spring of the bobbin case correctly. Reinsert the thread correctly. For details, refer to page 43.

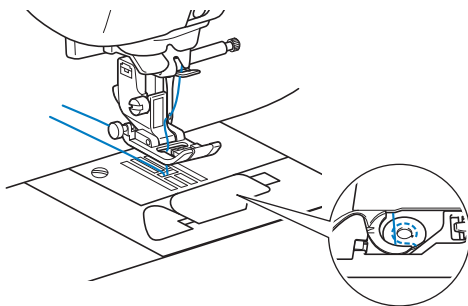

■ Upper Thread is Too Loose

If the upper thread is visible from the wrong side of the fabric, the upper thread is too loose.



Note

- If the upper thread was incorrectly threaded, the upper thread may be too loose. In this case, refer to “Upper Threading” (page 46) and rethread the upper thread.

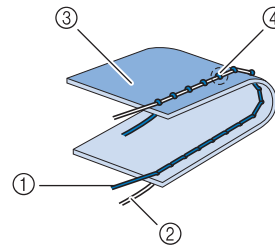

- ① Upper thread
- ② Bobbin thread
- ③ Wrong side
- ④ Locks appear on wrong side of fabric

Press  , to tighten the upper thread.



Memo

- Press  to return the thread tension to the original setting.

USEFUL FUNCTIONS

2

Sewing Basics

Automatic Reinforcement Stitching

After selecting a stitch pattern, turn on the automatic reinforcement stitching function before sewing, and the machine will automatically sew reinforcement stitches (or reverse stitches, depending on the stitch pattern) at the beginning and end of sewing.

- 1 Select a stitch pattern.
- 2 Press  to set the automatic reinforcement stitching function.

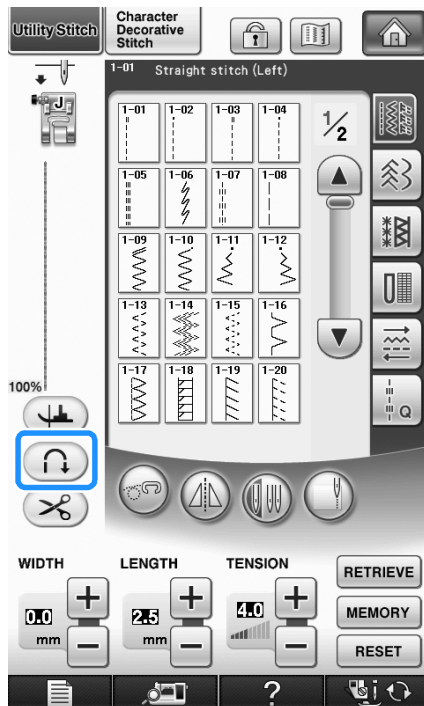

→ The key will display as .

Memo

- Some stitches, such as buttonholes and bar tacks, require reinforcement stitches at the beginning of sewing. If you select one of these stitches, the machine will automatically turn on this function (the key appears as  when the stitch is selected).

- 3 Set the fabric in the start position and start sewing.

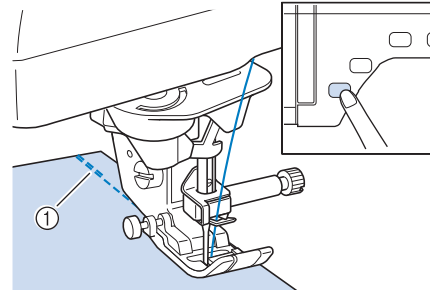

- ① Reverse stitches (or reinforcement stitches)
→ The machine will automatically sew reverse stitches (or reinforcement stitches) and then continue sewing.

Memo

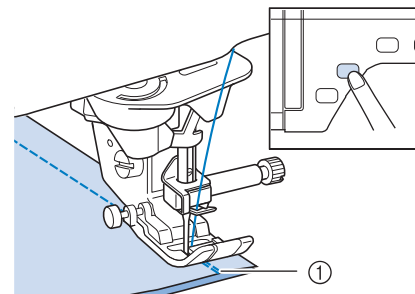

- If you press the “Start/Stop” button to pause sewing, press it again to continue. The machine will not sew reverse/reinforcement stitches again.

- 4 Press the “Reverse/Reinforcement Stitch” button.



- ① Reverse stitches (or reinforcement stitches)
→ The machine will sew reverse stitches (or reinforcement stitches) and stop.

Memo

- To turn off the automatic reinforcement stitching function, press  again, so it appears as .

Automatic Thread Cutting

After selecting a stitch pattern, turn on the automatic thread cutting function before sewing, and the machine will automatically sew reinforcement stitches (or reverse stitches, depending on the stitch pattern) at the beginning and end of sewing, and trim the threads at the end of sewing. This function is useful when sewing buttonholes and bar tacks.

- 1 Select a stitch pattern.
- 2 Press  to set the automatic thread cutting function.

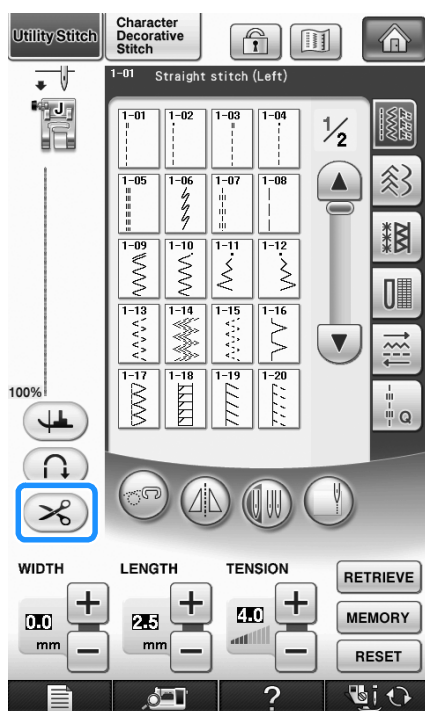

→ The key will display as .

-  **Memo**
- This function is set automatically when sewing embroidery.

- 3 Set the fabric in the start position and start sewing.

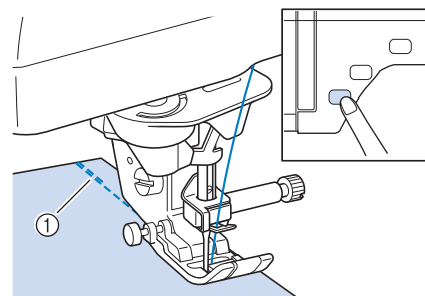



- ① Reverse stitches (or reinforcement stitches)
→ The machine will automatically sew reverse stitches (or reinforcement stitches) and then continue sewing.

-  **Memo**
- If you press the “Start/Stop” button to pause sewing, press the same button again to continue. The beginning reverse/reinforcement stitches will not be sewn again.

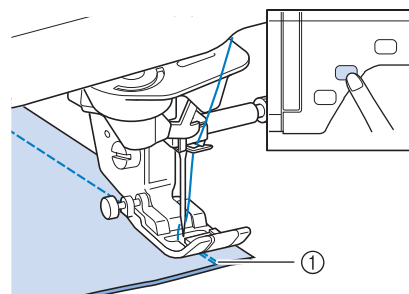
- 4 Press the “Reverse/Reinforcement Stitching” button.



- ① Reverse stitches (or reinforcement stitches)
→ The machine will sew reverse stitches (or reinforcement stitches), then trim the thread.

-  **Memo**
- To turn off the automatic thread cutting function, press  again, so it appears as .

Using the Knee Lifter

Using the knee lifter, you can raise and lower the presser foot with your knee, leaving both hands free to handle the fabric.

- 1 **Change the operating position of the knee lifter handle before inserting into the machine.**
Slide up the knee lifter handle slightly and rotate it while releasing pressure so handle will click into position.

* The knee lifter can be adjusted to three different angles.

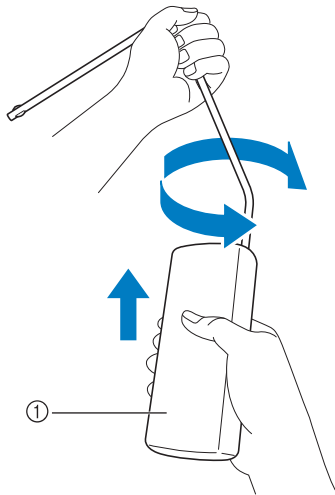

① Knee lifter handle

→ Rotate knee lifter handle till it clicks into the selected position that is most comfortable for you.

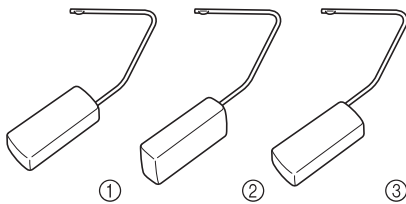

- 2 **Align the tabs on the knee lifter with the notches in the knee lifter slot on the front of the machine. Insert the knee lifter bar as far as possible.**

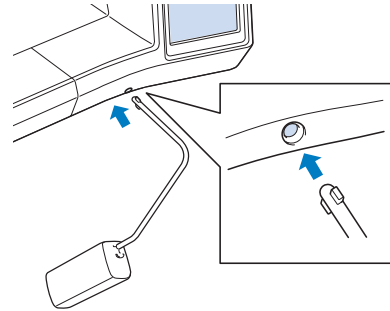

⚠ CAUTION

- Only change position of the knee lifter handle when knee lifter is not on the machine, otherwise the knee lifter may damage the mounting slot on front of the machine.



Note

- If the knee lifter bar is not pushed into the mounting slot as far as possible, it may come out during use.

- 3 **Use your knee to move the knee lifter bar to the right in order to raise the presser foot. Release the knee lifter to lower the presser foot.**

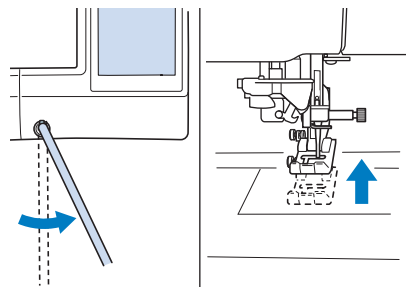

⚠ CAUTION

- Be sure to keep your knee away from the knee lifter during sewing. If the knee lifter is pushed during machine operation, the needle may break or the thread tension may loosen.



Memo

- When the presser foot is in the up position, move the knee lifter to the far right and then release to return the presser foot to the down position.

Pivoting

If the pivot setting is selected, the machine stops with the needle lowered (in the fabric) and the presser foot is automatically raised to an appropriate height when the “Start/Stop” button is pressed. When the “Start/Stop” button is pressed again, the presser foot is automatically lowered and sewing continues. This function is useful for stopping the machine to rotate the fabric.

CAUTION

- When the pivot setting is selected, the machine starts when the “Start/Stop” button is pressed or the foot controller is pressed down even if the presser foot has been raised. Be sure to keep your hands and other items away from the needle, otherwise injuries may occur.

Memo

- When the pivot setting is selected, the height of the presser foot when sewing is stopped can be changed according to the type of fabric being sewn. Press to display “Pivoting Height” on 2/7 of the settings screen. Press or to select one of the three heights (3.2 mm, 5.0 mm or 7.5 mm). To raise the presser foot further, increase the setting. (Normally, 3.2 mm is set.)



Note

- The “Needle Position – UP/DOWN” (3/7 of the settings screen) must be set in the down position for the pivot function to be used. When “Needle Position – UP/DOWN” is set in the raised position, appears as light gray and cannot be used.
- The pivot function can only be used with stitches where presser foot J or N is indicated in the upper-left corner of the screen. If any other stitch is selected, appears as light gray and is not available.
- Use the “Presser Foot Lifter” button to make sure the presser foot is lowered, and then press the “Start/Stop” button to continue sewing.
- If the pivot setting is selected, and beside “Presser Foot Height” in the settings screen are not available and the setting cannot be changed.

1 Select a stitch.

2 Press to select the pivot setting.

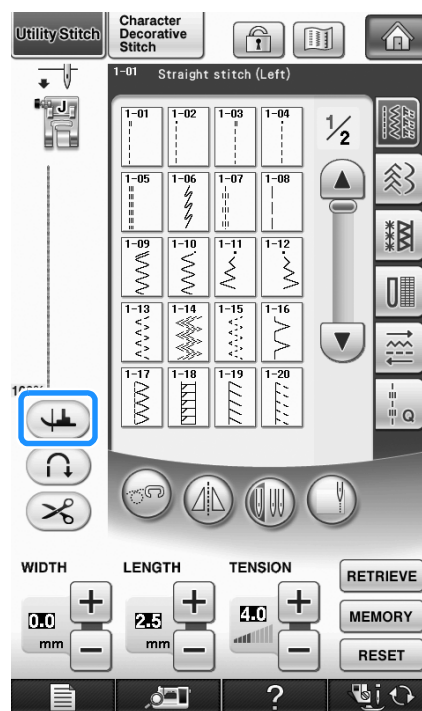

→ The key appears as .

- 3** Place the fabric under the presser foot with the needle at the starting point of the stitching, and then press the “Start/Stop” button. The machine will begin sewing.

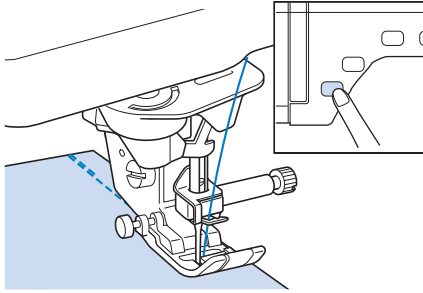

Memo

- If you press the “Start/Stop” button to pause sewing, press it again to continue, reverse stitches (or reinforcement stitches) will not be sewn.

- 4** Press the “Start/Stop” button to stop the machine at the point where the sewing direction changes.

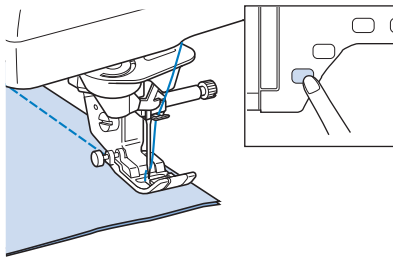

→ The machine stops with the needle in the fabric, and the presser foot is raised.

- 5** Rotate the fabric, and then press the “Start/Stop” button.

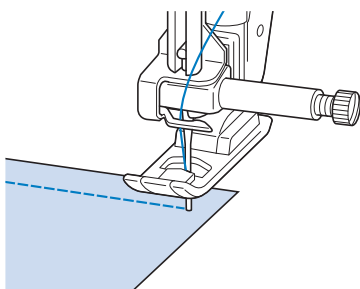

→ The presser foot is automatically lowered, and sewing continues.

Automatic Fabric Sensor System (Automatic Presser Foot Pressure)

The thickness of the fabric is automatically detected and the presser foot pressure is automatically adjusted with an internal sensor while sewing, to insure that your fabric is fed smoothly. The fabric sensor system works continuously while sewing. This function is useful for sewing over thick seams (see page 63), or quilting (see page 102).

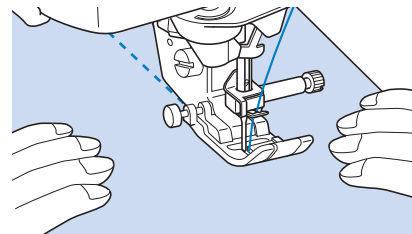
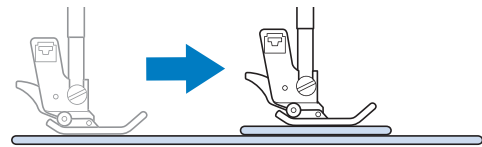

- 1** Press .

→ The settings screen appears.

- 2** Set “Automatic Fabric Sensor System” to “ON”.



- 3** Press  to return to the original screen.

Needle Position – Stitch Placement

When the “Needle Position – Stitch Placement” is on, the needle will be partially lowered for precise stitch placement and then press the “Needle Position” button to lower the needle completely. Each press of the “Needle Position” button changes the needle to the next position. When the “Needle Position – Stitch Placement” is turned off, each press of the “Needle Position” button simply raises and then lowers the needle.

- ① Pointing needle mode is ON
- ② Pointing needle mode is OFF

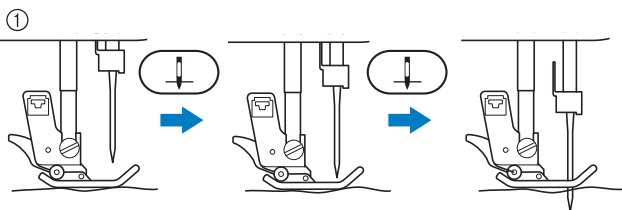

* When the needle is nearly lowered by pressing the “Needle Position” button, the feed dogs are lowered. At this time, the fabric can be shifted to finely adjust the needle drop position.

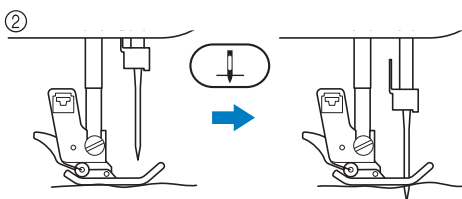

- 1 Press  .

- 2 Set “Needle Position – Stitch Placement” to “ON” or “OFF”.

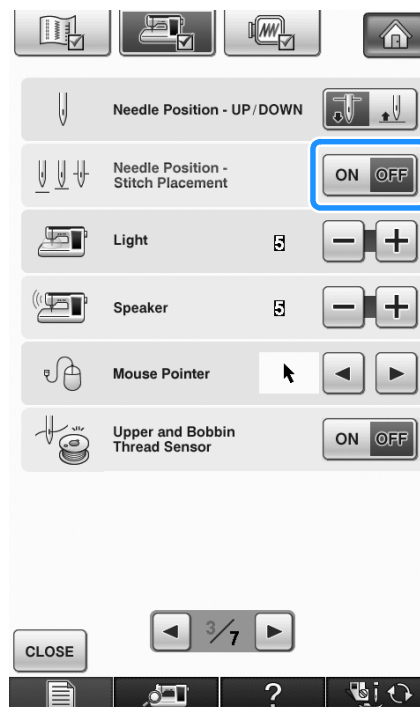

- 3 Press  to return to the original screen.

Locking the Screen

If the screen is locked before starting to sew, the various settings such as the stitch width and stitch length are locked and cannot be changed. This prevents screen settings from accidentally being changed or the machine from being stopped while large pieces of fabric or projects are being sewn. The screen can be locked when sewing utility stitches and character decorative stitches.



- 1 Select a stitch pattern.
- 2 If necessary, adjust any settings such as the stitch width and stitch length.
- 3 Press  to lock the screen settings.

→ The key appears as  .

4 Sew your project.

5 When you are finished sewing, press  again to unlock the screen settings.

CAUTION

- If the screen is locked (), unlock the screen by pressing  . While the screen is locked, no other key can be operated.
- The settings are unlocked when the machine is turned off and on.

Checking the Needle Location in the Screen

Press  to use the built-in camera to view the sewing area in the LCD screen. View the location of the needle from 2 different angles and the needle drop position, even if the needle has not actually been lowered.

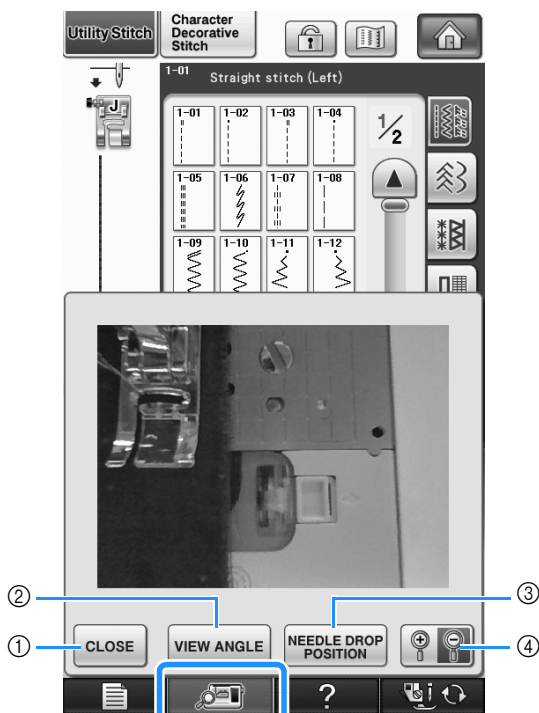

→ The camera view window appears.

- ① CLOSE
- ② VIEW ANGLE
- ③ NEEDLE DROP POSITION
- ④ ZOOM

CLOSE

Press this key to close the screen.

VIEW ANGLE

Each press of  switches the built-in camera between a front view and an angled top view.

NEEDLE DROP POSITION

Press  to show the needle drop position in the screen as “+”.

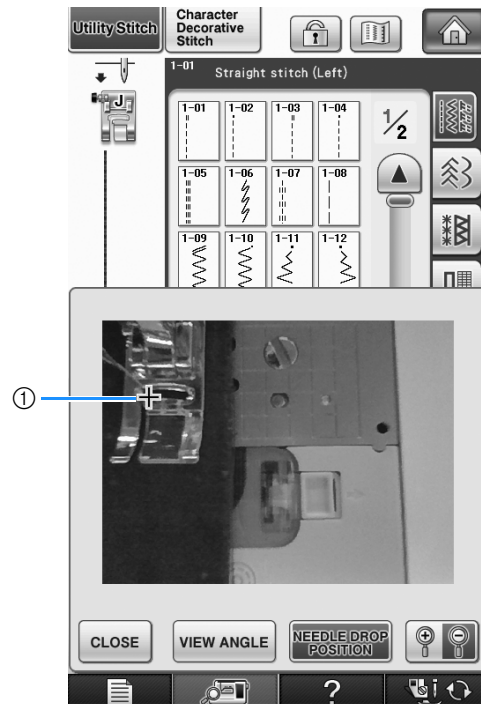

- ① Needle drop position

ZOOM

Press  to enlarge the image in the screen.

Press  again to return the image to its original display size.



Note

- The camera view window disappears when you start sewing.
- When sewing thick fabrics, the needle drop position indicated in the screen may differ from the actual position.



Chapter 3

Utility Stitches

SELECTING UTILITY STITCHES.....	78
■ Stitch Selection Screens.....	78
Selecting a Stitch	79
■ Using the Mirror Image Key.....	79
■ Using the Image Key.....	80
Saving Your Stitch Settings	81
■ Saving Settings.....	81
■ Retrieving Saved Settings.....	82
SEWING THE STITCHES.....	83
Straight Stitches	83
■ Changing the Needle Position (Left or Middle Needle Position Stitches Only)	85
■ Aligning the Fabric with a Mark on the Needle Plate or Bobbin Cover (with Mark)	85
■ Aligning the Fabric with the Vertical Stitch Alignment “V” Foot	86
■ Using the Straight Stitch Needle Plate and the Straight Stitch Foot	86
■ Basting	87
Dart Seam.....	88
Gathering.....	88
Flat Fell Seam.....	89
Pintuck.....	90
Zigzag Stitches.....	91
■ Overcasting (Using a Zigzag Stitch)	91
■ Appliqué (Using a Zigzag Stitch)	91
■ Patchwork (for Crazy Quilt).....	92
■ Sewing Curves (Using a Zigzag Stitch)	92
■ Cord Guide Bobbin Cover (Using a Zigzag Stitch)	92
Elastic Zigzag Stitches.....	93
■ Tape Attaching	93
■ Overcasting.....	93
Overcasting	94
■ Overcasting Using Presser Foot “G”	94
■ Overcasting Using Presser Foot “J”	95
■ Overcasting Using the Side Cutter	96
■ When Sewing Straight Stitches While Using the Side Cutter	98
Quilting	99
■ Piecing	102
■ Quilting.....	102
■ Appliqué.....	103
■ Quilting with Satin Stitches	104
■ Free Motion Quilting.....	105
■ Echo Quilting Using the Free Motion Echo Quilting Foot “E”.....	108
Blind Hem Stitches	111
■ If the Needle Catches Too Much of the Hem Fold	113
■ If the Needle does not Catch the Hem Fold	113
Appliqué	113
■ Appliqué Sharp Curves	114
■ Appliqué Corners	114
Shelltuck Stitches.....	114
Scallop Stitches.....	115
Crazy Quilting	116
Smocking Stitches	116
Fagoting.....	117
Tape or Elastic Attaching.....	117
Heirloom	119
■ Hemstitching (1) (Daisy Stitch).....	119
■ Hemstitching (2) (Drawn Work (1)).....	119
■ Hemstitching (3) (Drawn Work (2)).....	120
One-step Buttonholes	121
■ Sewing Stretch Fabrics.....	124
■ Odd Shaped Buttons/Buttons that do Not Fit into the Button Holder Plate.....	124
Four-step Buttonholes.....	125
■ Darning.....	127
Bar Tacks.....	129
■ Bar Tacks on Thick Fabrics.....	130
Button Sewing	131
■ Attaching 4 Hole Buttons.....	132
■ Attaching a Shank to the Button	132
Eyelet.....	133
Multi-directional Sewing (Straight Stitch and Zigzag Stitch)	134
Zipper Insertion.....	135
■ Centered Zipper.....	135
■ Inserting a Side Zipper	136
Edge Sewing.....	138

SELECTING UTILITY STITCHES

Stitch Selection Screens

There are 6 categories of Utility Stitches. If a page number such as 1/2 appears, there is more than one stitch selection screen for that category.

Straight/Overcasting

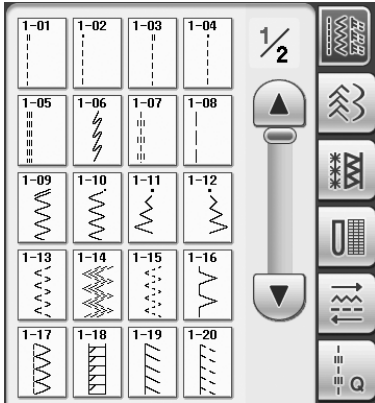

Decorative Stitches

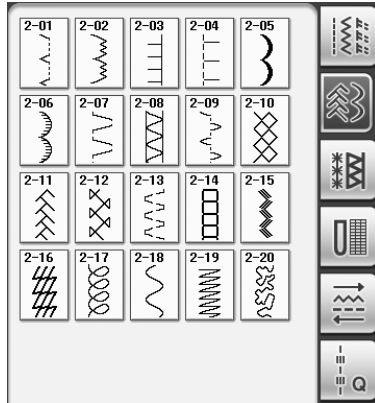

Heirloom Stitches

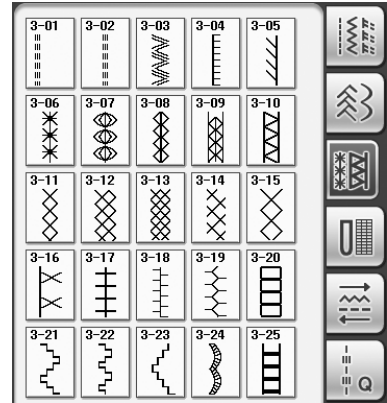

Buttonholes/Bar tacks

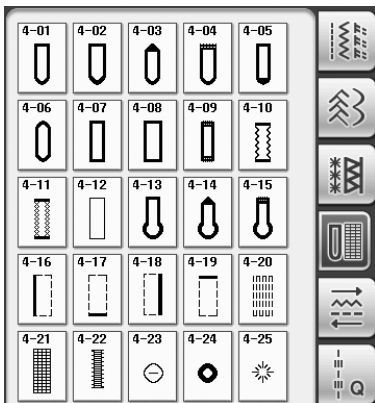

Multi-directional Sewing

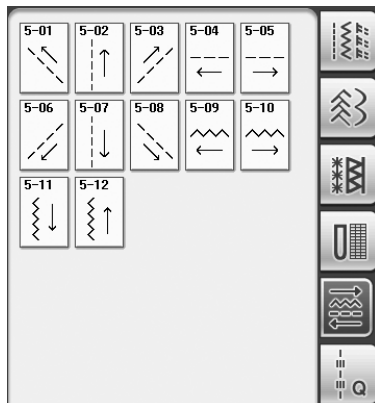

Quilting Stitches

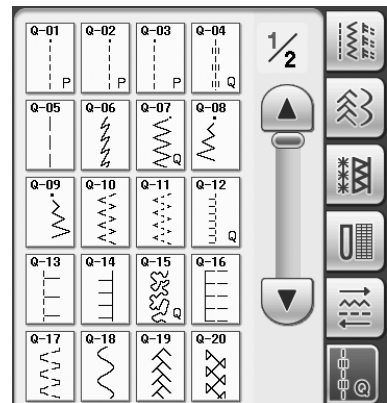

Selecting a Stitch

1 Turn the main power to ON and press

 to display the utility stitches.

→ Either “1-01 Straight stitch (Left)” or “1-03 Straight stitch (Middle)” is selected, depending on the setting selected in the setting screen.

2 Use  to select the category you want.

* Press  to view the next page.

* Press  to view previous page.

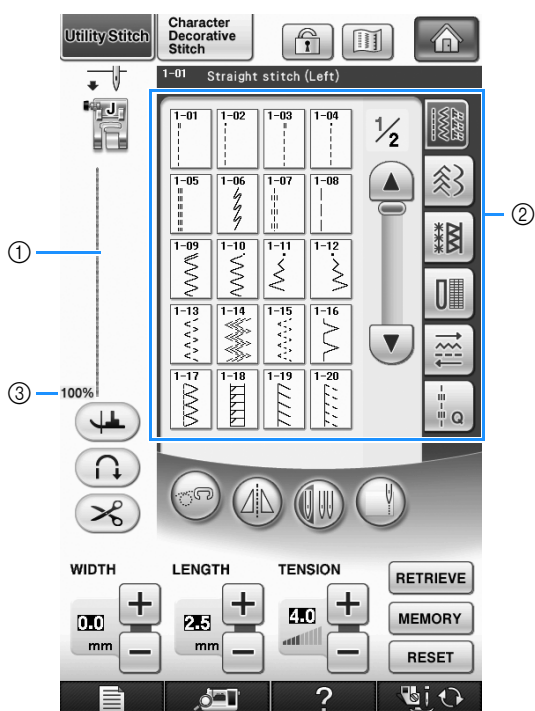

① Preview of the selected stitch

② Stitch selection screen

③ Percentage size of view

3 Press the key of the stitch you want to sew.

Memo

- For details on each stitch, refer to the “STITCH SETTING CHART” at the end of this manual.

Using the Mirror Image Key

Depending on the type of utility stitch you select, you may be able to sew a horizontal mirror image of the stitch.

If  is lit when you select a stitch, it will be possible to make a mirror image of the stitch.

Note

- If  is light gray after you select a stitch, you cannot create a horizontal mirror image of the selected stitch due to the type of stitch or type of presser foot recommended (this is true of buttonholes, multi-directional sewing, and others).

Press  to create a horizontal mirror image of the selected stitch.

The key will display as .





Using the Image Key

You can display an image of the selected stitch. You can check and change the colors of the image of the screen.

1 Press .

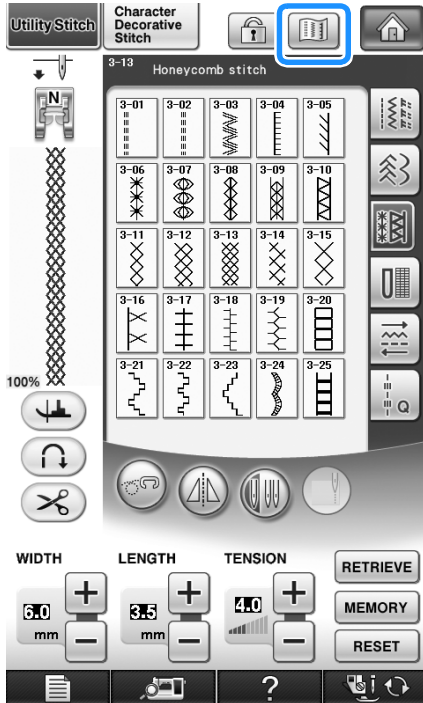
→ An image of the selected stitch is displayed.



2 Press  to change the thread color of the stitch on the screen.

* Press  to display an enlarged image of the stitch.

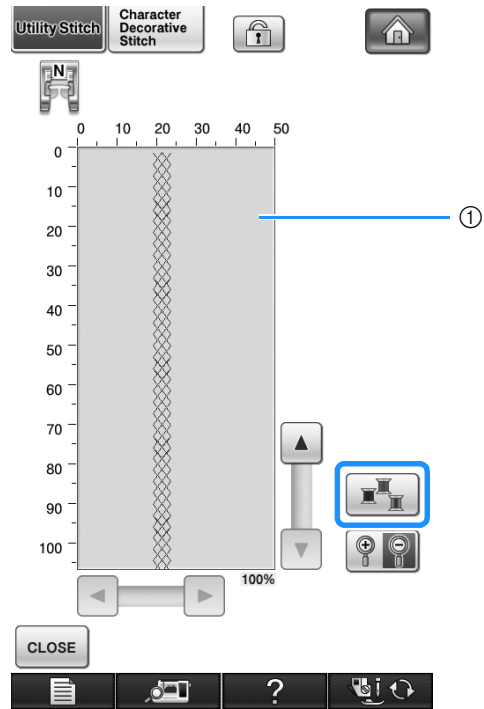

① Stitch screen



Memo

- The color changes every time you press .
- The units of the stitch display in mm.



Note

- If stitches are wider or larger than display, press darkened arrows to move the stitch pattern for better visibility.

3 Press  to go back to the original screen.

Saving Your Stitch Settings

The settings for the zigzag stitch width, stitch length, thread tension, automatic thread cutting, automatic reinforcement stitching, etc., are preset in the machine for each stitch. However, if you have specific settings that you wish to reuse later for a stitch, you can change the settings so that they can be saved for that stitch. Five sets of settings can be saved for a single stitch.

■ Saving Settings

1 Select a stitch. (Example: )

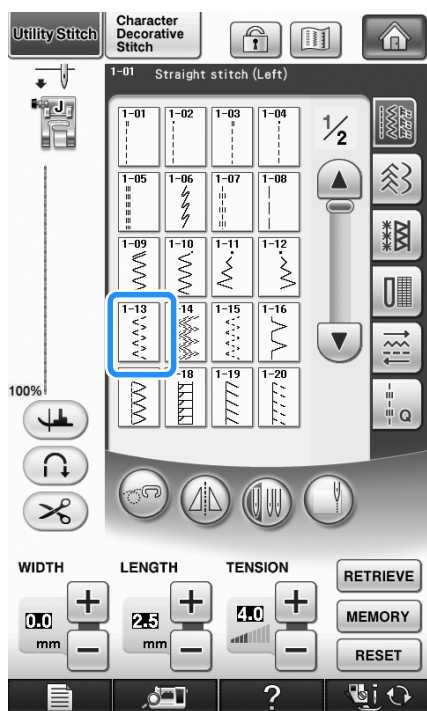

2 Specify your preferred settings.

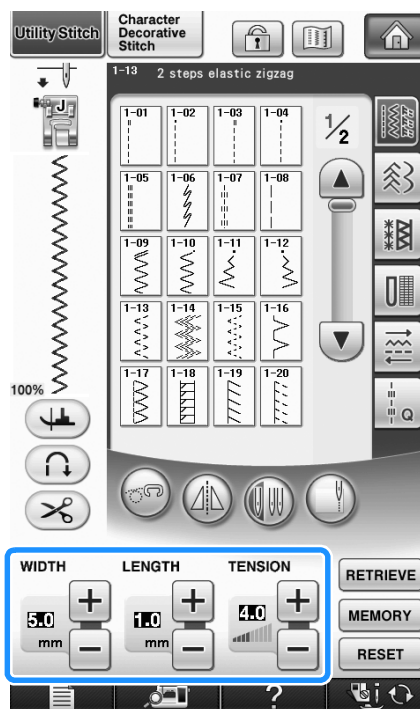

3 Press **MEMORY**.

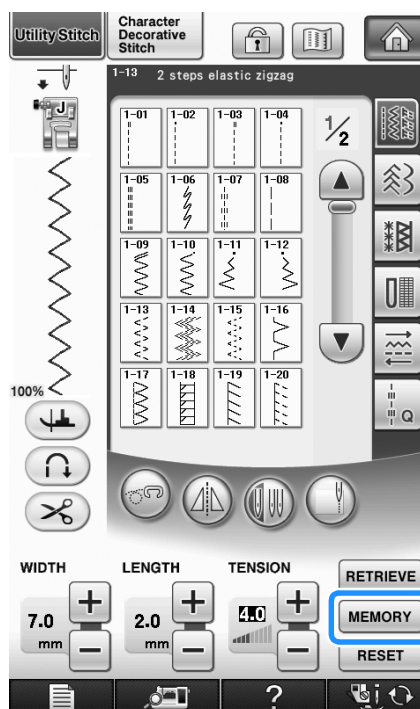

→ The settings are saved and the original screen automatically appears.

Memo

- If you try to save settings when there are already 5 sets of settings saved for a stitch, the message “The pockets are full. Delete a pattern” will appear. Close the message and delete a setting referring to page 82.

3

Utility Stitches

Retrieving Saved Settings

1 Select a stitch.

Memo

- When a stitch is selected, the last settings retrieved are displayed. The last settings retrieved are retained even if the machine was turned off or a different stitch was selected.

2 Press **RETRIEVE**.

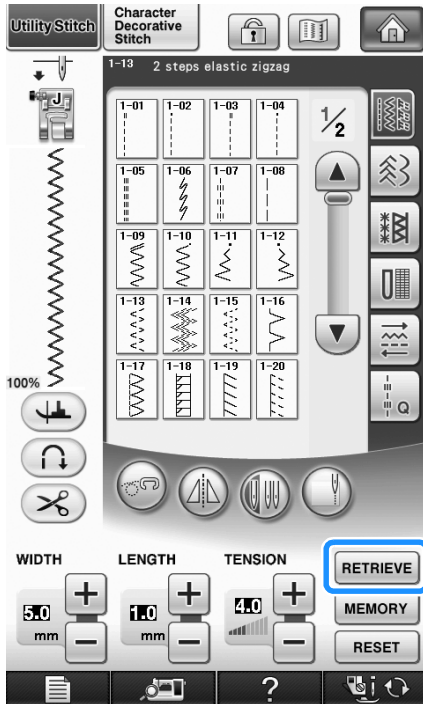

3 Press the numbered key of the settings to be retrieved.

- * Press **CLOSE** to return to the original screen without retrieving settings.

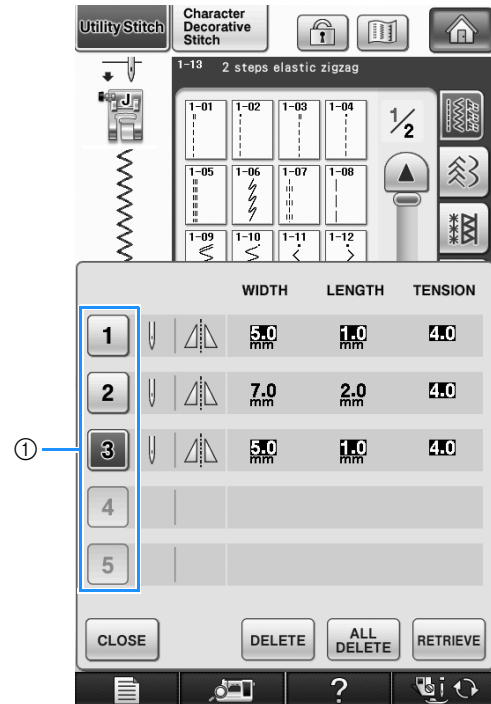

① Numbered keys

4 Press **RETRIEVE**.

- The selected settings are retrieved, and the original screen automatically appears.

Memo









- To save new settings when there are already 5 sets of settings saved for a stitch, press **RETRIEVE**. Press the numbered key of the setting to be deleted. Press **DELETE**, press **CLOSE** and then **MEMORY**. The new setting will be saved in place of the recently deleted setting.
- You can delete all the saved settings by pressing **ALL DELETE**.

SEWING THE STITCHES

3

Utility Stitches

Straight Stitches

Stitch	Stitch name	Presser foot	Applications	Stitch width [mm (inch)]		Stitch length [mm (inch)]		Twin needle
				Auto	Manual	Auto	Manual	
1-01	Straight stitch (Left)		General sewing, gather, pintuck, etc. Reverse stitch is sewn while pressing "Reverse/Reinforcement Stitch" button.	0.0 (0)	0.0 - 7.0 (0 - 1/4)	2.5 (3/32)	0.2 - 5.0 (1/64 - 3/16)	OK (J)
1-02	Straight stitch (Left)		General sewing, gather, pintuck, etc. Reinforcement stitch is sewn while pressing "Reverse/Reinforcement Stitch" button.	0.0 (0)	0.0 - 7.0 (0 - 1/4)	2.5 (3/32)	0.2 - 5.0 (1/64 - 3/16)	OK (J)
1-03	Straight stitch (Middle)		General sewing, gather, pintuck, etc. Reverse stitch is sewn while pressing "Reverse/Reinforcement Stitch" button.	3.5 (1/8)	0.0 - 7.0 (0 - 1/4)	2.5 (3/32)	0.2 - 5.0 (1/64 - 3/16)	OK (J)
1-04	Straight stitch (Middle)		General sewing, gather, pintuck, etc. Reinforcement stitch is sewn while pressing "Reverse/Reinforcement Stitch" button.	3.5 (1/8)	0.0 - 7.0 (0 - 1/4)	2.5 (3/32)	0.2 - 5.0 (1/64 - 3/16)	OK (J)
1-05	Triple stretch stitch		General sewing for reinforcement and decorative topstitching	0.0 (0)	0.0 - 7.0 (0 - 1/4)	2.5 (3/32)	1.5 - 4.0 (1/16 - 3/16)	OK (J)
1-06	Stem stitch		Reinforced stitching, sewing and decorative applications	1.0 (1/16)	1.0 - 3.0 (1/16 - 1/8)	2.5 (3/32)	1.0 - 4.0 (1/16 - 3/16)	OK (J)
1-07	Decorative stitch		Decorative stitching, top stitching	0.0 (0)	0.0 - 7.0 (0 - 1/4)	2.5 (3/32)	1.0 - 4.0 (1/16 - 3/16)	OK (J)
1-08	Basting stitch		Basting	0.0 (0)	0.0 - 7.0 (0 - 1/4)	20 (3/4)	5 - 30 (3/16 - 1-3/16)	NO

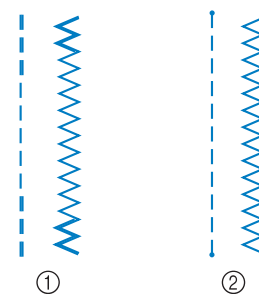
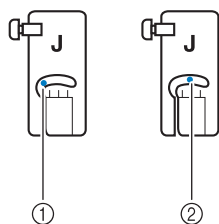

- ① Left needle position
- ② Middle needle position

- ① Reverse stitch
- ② Reinforcement stitch

Memo

- If the selected stitch has a double mark " " at the top of the key display, you can sew reverse stitches holding the "Reverse/Reinforcement Stitch" button.
- If the selected stitch has a dot mark " · " at the top of the key display, you can sew reinforcement stitches holding the "Reverse/Reinforcement Stitch" button (see page 62).

1 Select a stitch.

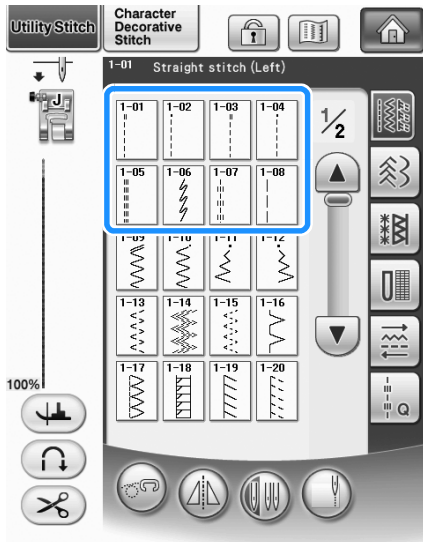

2 Attach presser foot "J".

* Attach presser foot "N" when you select .

3 Hold the thread tail and fabric with your left hand, and rotate the handwheel with your right hand to insert the needle into the fabric.

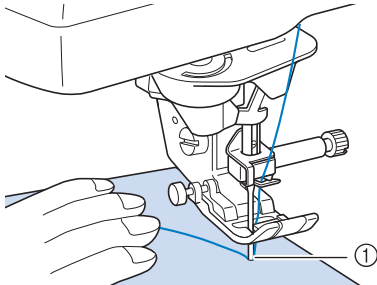

① Sewing start position

4 Lower the presser foot, and hold the "Reverse/Reinforcement Stitch" button to sew 3-4 stitches.

→ The machine sews reverse stitches (or reinforcement stitches).

5 Press the "Start/Stop" button to sew forward.

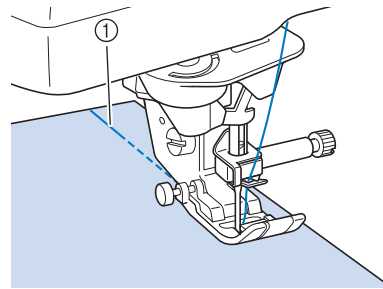

① Reverse stitches
→ The machine will begin sewing slowly.

! CAUTION

- Be sure the needle does not strike a basting pin, or any other objects, during sewing. The thread could tangle or the needle could break, causing injury.

6 When sewing is completed, hold the "Reverse/Reinforcement Stitch" button to sew 3-4 reverse stitches (or reinforcement stitches) at the end of the seam.

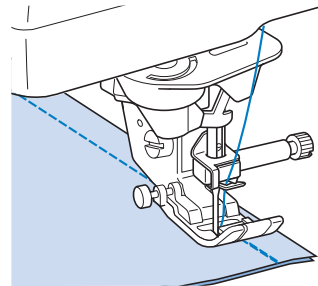

7 After sewing, press the "Thread Cutter" button to trim the threads.

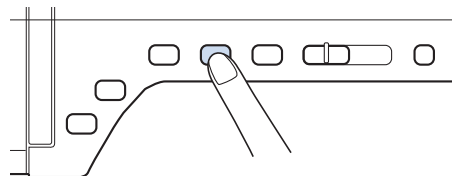

Memo

- When the automatic thread cutting and automatic reinforcement stitch keys on the screen are selected, reverse stitches (or reinforcement stitches) will be sewn automatically at the beginning of sewing when the "Start/Stop" button is pressed. Press the "Reverse/Reinforcement Stitch" button to sew reverse stitches (or reinforcement stitches) and trim the thread automatically at the end of sewing.

■ Changing the Needle Position (Left or Middle Needle Position Stitches Only)

When you select left or middle needle position stitches, you can use **-** and **+** in the stitch width display to change the position of the needle. Match the distance from the right edge of the presser foot to the needle with the stitch width, then align the edge of the presser foot with the edge of the fabric during sewing for an attractive finish.

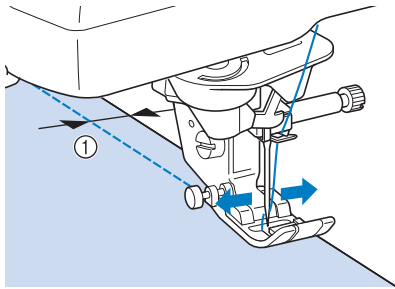

① Stitch width

Example: Left/Middle needle position stitches

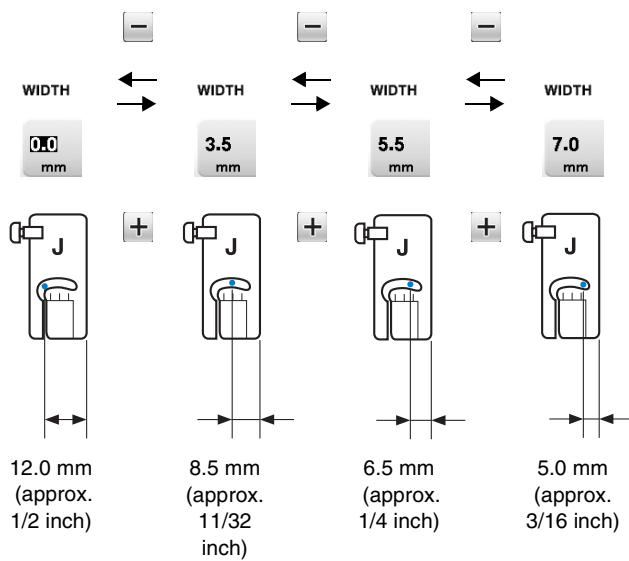

■ Aligning the Fabric with a Mark on the Needle Plate or Bobbin Cover (with Mark)

While sewing, align the edge of the fabric with the 16 mm (approx. 5/8 inch) mark on the needle plate or bobbin cover (with mark) depending on the needle position (left or middle (center) needle position stitches only).

For stitches with a left needle position (Stitch width: 0.0 mm)

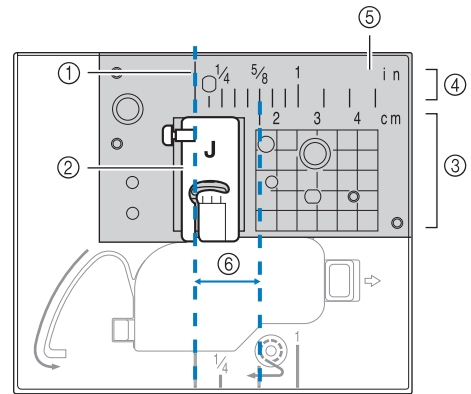

- ① Seam
- ② Presser foot
- ③ Centimeters
- ④ Inches
- ⑤ Needle plate
- ⑥ 16 mm (5/8 inch)

For stitches with a middle (center) needle position (Stitch width: 3.5 mm)

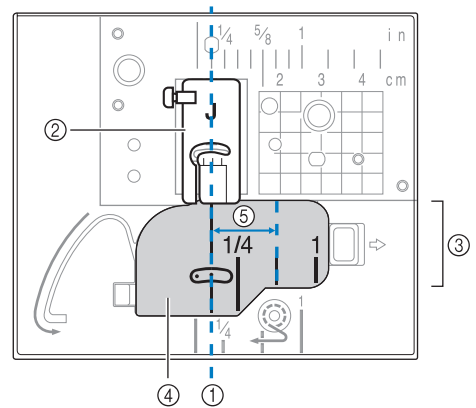

- ① Seam
- ② Presser foot
- ③ Inches
- ④ Bobbin cover (with mark)
- ⑤ 16 mm (5/8 inch)

■ Aligning the Fabric with the Vertical Stitch Alignment “V” Foot

Sew while keeping the right edge of the fabric aligned with a desired position of markings on the vertical stitch alignment “V” foot. You can also use the vertical stitch alignment “V” foot for setting a stitch width using the built-in camera (see page 138).

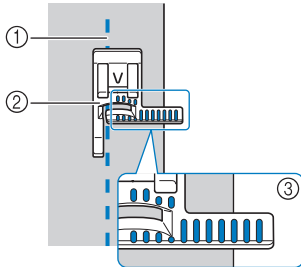

- ① Seam
- ② Vertical stitch alignment “V” foot
- ③ Markings

■ Using the Straight Stitch Needle Plate and the Straight Stitch Foot

The straight stitch needle plate and the straight stitch foot can only be used for straight stitches (middle needle position stitches). Use the straight stitch needle plate and the straight stitch foot when sewing thin fabrics or when sewing small pieces which tend to sink into the hole of the regular needle plate during sewing. The straight stitch foot is perfect to reduce puckering on lightweight fabrics. The small opening on the foot provides support for the fabric as the needle travels through the fabric.

⚠ CAUTION

- Always use the straight stitch foot in combination with the straight stitch needle plate.

- 1 Press the “Needle Position” button to raise the needle and turn the main power to OFF or press .
- 2 Remove the needle and the presser foot holder (see page 55 through 56).
- 3 Remove the flat bed attachment or the embroidery unit if either are attached.

- 4 Grasp both sides of the needle plate cover, and then slide it toward you.

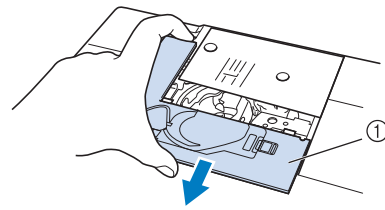

- ① Needle plate cover

- 5 Grasp the bobbin case, and then pull it out.

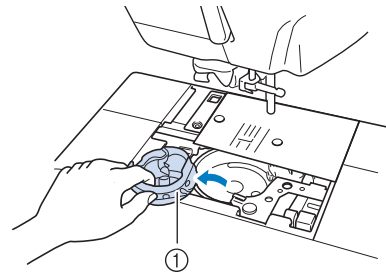

- ① Bobbin case

- 6 Use the disc-shaped screw driver included with the machine to unscrew and remove the regular needle plate.

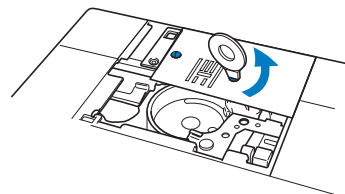

- 7 Set the straight stitch needle plate in place and use the disc-shaped screw driver to tighten the plate.

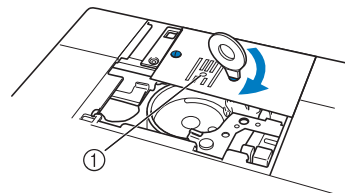

- ① Round hole

💡 Note

- Align the two screw holes on the needle plate with the two holes on the machine. Use the disc-shaped screw driver included with the machine to secure the screws in the needle plate.

- 8 Insert the bobbin case in its original position, and then attach the needle plate cover.
- 9 After reinstalling the needle plate cover, select any of the straight stitches.

Memo

- When using the straight stitch needle plate, all straight stitches become middle needle position stitches. You cannot change the needle position using the width display.
- Always secure the needle plate before inserting the bobbin case into its original position.

CAUTION

- Selecting other stitches will cause an error message to be displayed.
- Slowly rotate the handwheel toward you (counterclockwise) before sewing and make sure that the needle is not contacting the straight stitch foot and straight stitch needle plate.

- 10 Insert needle and attach the straight stitch foot.

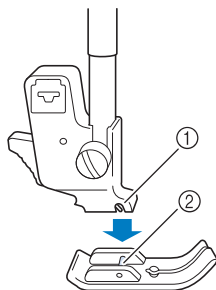

- ① Notch
- ② Pin

- 11 Start sewing.

- * After sewing, make sure to remove the straight stitch needle plate and the straight stitch foot, and reinstall the regular needle plate, the needle plate cover and the presser foot "J".

Memo

- To prevent puckering on fine fabrics, use a fine needle, size 75/11, and a short stitch length. For heavier fabrics, use a heavier needle, size 90/14, and longer stitches.

■ Basting

- 1 Select  and attach presser foot "J".
- 2 Press the "Reverse/Reinforcement Stitch" button to sew reinforcement stitches, then continue sewing.

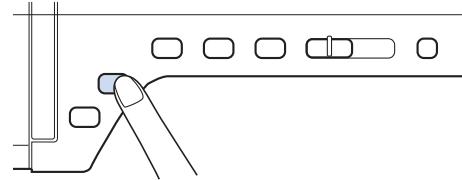

Memo

- When you use the basting stitch for gathering, do not use a reinforcement stitch at the beginning; you should lift the presser foot, rotate the handwheel toward you (counterclockwise), pull up the bobbin thread and pull a length of top and bobbin thread out from the rear of the machine.
- You can set the stitch length between 5 mm (approx. 3/16 inch) and 30 mm (approx. 1-3/16 inches)



- ① Between 5 mm (approx. 3/16 inch) and 30 mm (approx. 1-3/16 inches)

- 3 Sew while keeping the fabric straight.

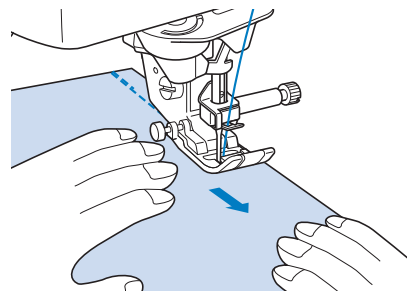

- 4 End the basting with reinforcement stitches.

Dart Seam

- 1 Select  and attach presser foot "J".
- 2 Sew a reverse stitch at the beginning of the dart and then sew from the wide end to the other end without stretching the fabric.

* If automatic reinforcement stitching is preset, a reinforcement stitch will automatically be sewn at the beginning of sewing.

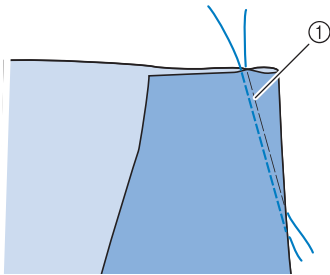

① Basting

- 3 Cut the thread at the end leaving 50 mm (approx. 1-15/16 inches), and then tie both ends together.

* Do not sew a reverse stitch at the end.

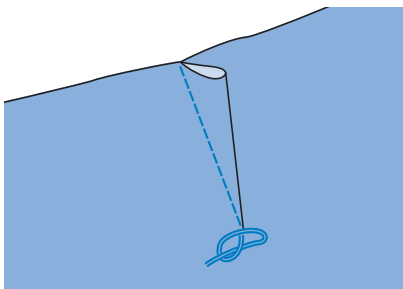

- 4 Insert the ends of the thread into the dart with a hand sewing needle.

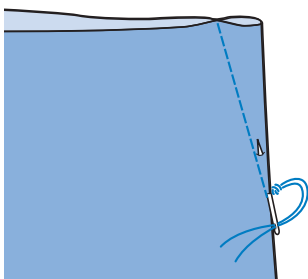

- 5 Iron the dart to one side so that it is flat.

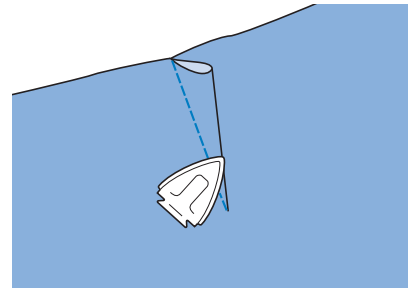



Gathering

Use on waists of skirts, sleeves of shirts, etc.

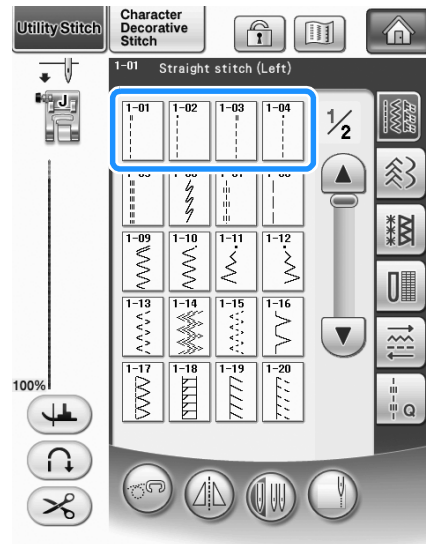
- 1 Select a straight stitch and attach presser foot "J".



- 2 Set the stitch length to 4.0 mm (approx. 3/16 inch) and the thread tension to approximately 2.0 (weaker tension).

* If you press  after pressing  and then , the stitch length will be set automatically to 4.0 mm (approx. 3/16 inch) and the thread tension will be automatically set to 2.0.

- 3** Pull the bobbin and upper threads out by 50 mm (approx. 1-15/16 inches) (see page 45).

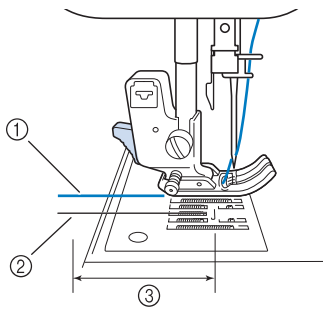

- ① Upper thread
② Bobbin thread
③ About 50 mm (approx. 1-15/16 inches)

- 4** Sew two rows of straight stitches parallel to the seam line, then trim excess thread leaving 50 mm (approx. 1-15/16 inches).

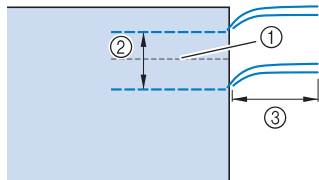

- ① Seam line
② 10 to 15 mm (approx. 3/8 inch to 9/16 inch)
③ About 50 mm (approx. 1-15/16 inches)

- 5** Pull the bobbin threads to obtain the desired amount of gather, then tie the threads.

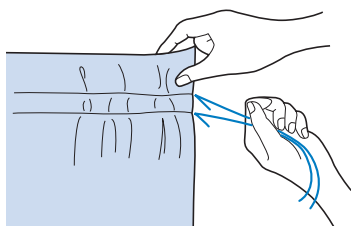

- 6** Smooth the gathers by ironing them.

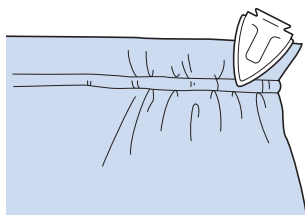

- 7** Sew on the seam line and remove the basting stitch.

Flat Fell Seam

Use for reinforcing seams and finishing edges neatly.

- 1** Select  and attach presser foot "J".
- 2** Sew the finish line, then cut half of the seam allowance from the side on which the flat fell seam will lie.

* When the automatic thread cutting and automatic reinforcement stitching are preset, reinforcement stitches will be sewn automatically at the beginning of sewing. Press the "Reverse/Reinforcement Stitch" button to sew a reinforcement stitch and trim the thread automatically at the end of sewing.

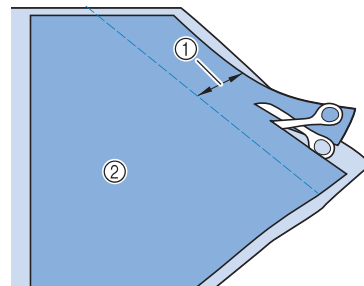

- ① About 12 mm (approx. 1/2 inch)
② Wrong side

- 3** Spread the fabric out along the finish line.

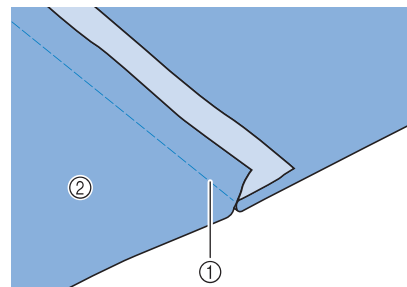

- ① Finish line
② Wrong side

- 4** Lay both seam allowances on the side of the shorter seam (cut seam) and iron them.

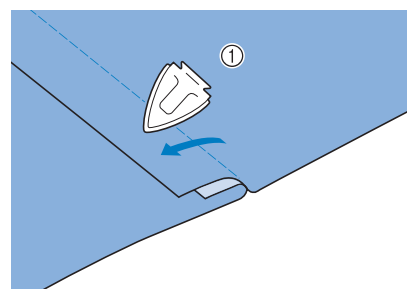

- ① Wrong side

5 Fold the longer seam allowance around the shorter one, and sew the edge of the fold.

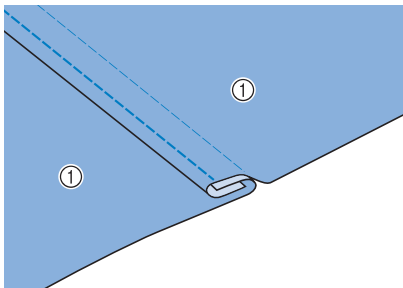

① Wrong side
Finished flat fell seam

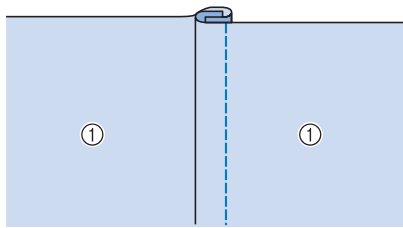

① Surface

Pintuck

1 Mark along the folds on the wrong side of the fabric.

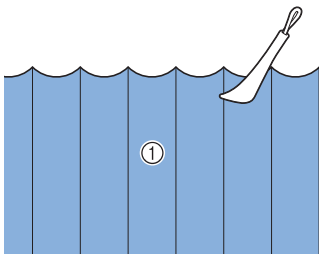

① Wrong side

2 Turn the fabric and iron the folded parts only.

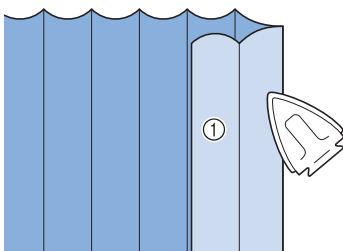

① Surface

3 Select  and attach presser foot "I".

4 Sew a straight stitch along the fold.

* When the automatic thread cutting and automatic reinforcement stitching are preset, reinforcement stitches will be sewn automatically at the beginning of sewing. Press the "Reverse/Reinforcement Stitch" button to sew a reinforcement stitch and trim the thread automatically at the end of sewing.

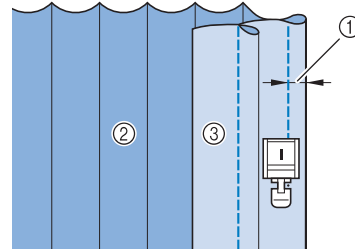

① Width for pintuck
② Wrong side
③ Surface

5 Iron the folds in the same direction.

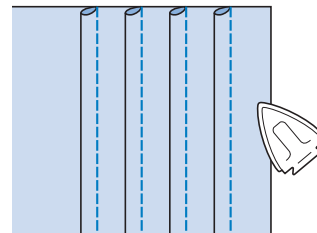









Zigzag Stitches

Zigzag stitches are useful for overcasting, appliqué, patchwork, and many other applications. Select a stitch, and attach presser foot “J”.

If the stitch which you select has a double mark “#” at the top of the key display, you can sew reverse stitches by holding the “Reverse/Reinforcement Stitch” button.

If the stitch which you select has a dot mark “·” at the top of the key display, you can sew reinforcement stitches by holding the “Reverse/Reinforcement Stitch” button (see page 62).

Stitch	Stitch name	Presser foot	Applications	Stitch width [mm (inch)]		Stitch length [mm (inch)]		Twin needle
				Auto	Manual	Auto	Manual	
	Zigzag stitch		For overcasting, mending. Reverse stitch is sewn while pressing “Reverse/Reinforcement Stitch” button.	3.5 (1/8)	0.0 - 7.0 (0 - 1/4)	1.4 (1/16)	0.0 - 4.0 (0 - 3/16)	OK (J)
	Zigzag stitch		For overcasting, mending. Reinforcement stitch is sewn while pressing “Reverse/Reinforcement Stitch” button.	3.5 (1/8)	0.0 - 7.0 (0 - 1/4)	1.4 (1/16)	0.0 - 4.0 (0 - 3/16)	OK (J)
	Zigzag stitch (right)		Start from right needle position, zigzag sew at left.	3.5 (1/8)	2.5 - 5.0 (3/32 - 3/16)	1.4 (1/16)	0.3 - 4.0 (1/64 - 3/16)	OK (J)
	Zigzag stitch (left)		Start from left needle position, zigzag sew at right.	3.5 (1/8)	2.5 - 5.0 (3/32 - 3/16)	1.4 (1/16)	0.3 - 4.0 (1/64 - 3/16)	OK (J)

1 Select a stitch.

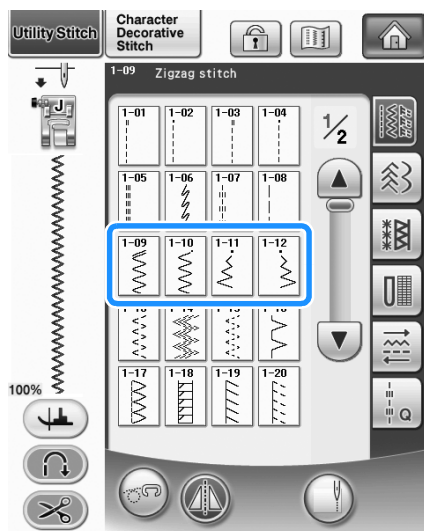

2 Attach presser foot “J”.

Overcasting (Using a Zigzag Stitch)

Sew the overcasting along the edge of the fabric while positioning the right-hand side needle drop point just outside the edge of the fabric.

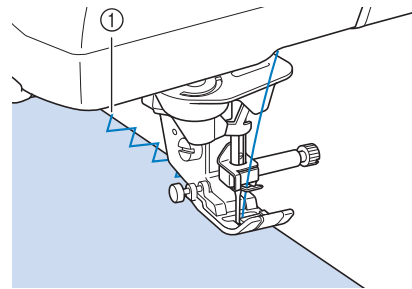

① Needle drop position

Appliqué (Using a Zigzag Stitch)

Attach the appliqué material using a temporary spray adhesive or basting, and then sew it.

* Sew a zigzag stitch while positioning the right-hand side needle drop point just outside the edge of the fabric.

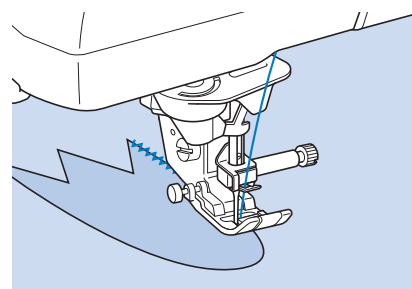

■ Patchwork (for Crazy Quilt)

Turn back the desired width of fabric and position it over the lower fabric, then sew so that the stitch bridges both pieces of fabric.

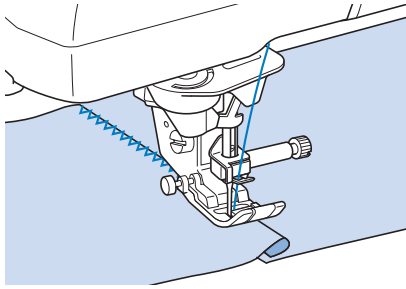

■ Sewing Curves (Using a Zigzag Stitch)

Shorten the stitch length setting to obtain a fine stitch. Sew slowly, keeping the seams parallel with the fabric edge as you guide the fabric around the curve.

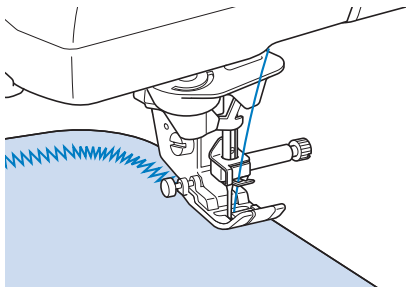

■ Cord Guide Bobbin Cover (Using a Zigzag Stitch)

- 1 Remove the bobbin cover from the machine (see page 43).
- 2 Thread the gimp thread through the hole in the cord guide bobbin cover from top to bottom. Position the thread in the notch at the back of the cord guide bobbin cover.

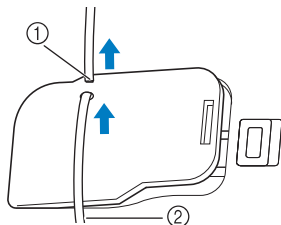

- ① Notch
- ② Gimp thread

- 3 Snap the cord guide bobbin cover into place, making sure that the gimp thread can be fed freely.

* Make sure there are no restrictions when feeding the thread.

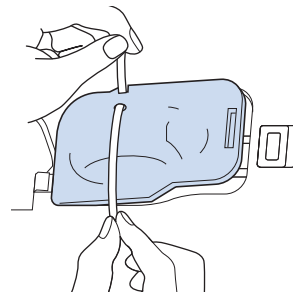

- 4 Set the zigzag width from 2.0-2.5 mm (approx. 1/16 - 3/32 inch).
- 5 Attach presser foot "N".
- 6 Position the fabric right side up on top of the cord and place the cord to the rear of the machine under the presser foot.

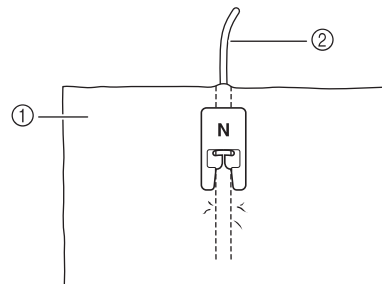





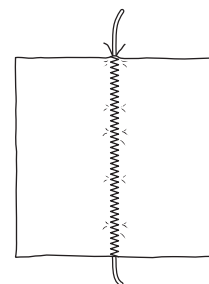

- ① Fabric (right side)
- ② Gimp thread

- 7 Lower the presser foot and start sewing to make a decorative finish.



Elastic Zigzag Stitches

Use elastic zigzag stitches for tape attaching, overcasting, darning, or a wide variety of other uses.

Stitch	Stitch name	Presser foot	Applications	Stitch width [mm (inch)]		Stitch length [mm (inch)]		Twin needle
				Auto	Manual	Auto	Manual	
	2 steps elastic zigzag		Overcasting (medium weight and stretch fabrics), tape and elastic	5.0 (3/16)	1.5 - 7.0 (1/16 - 1/4)	1.0 (1/16)	0.2 - 4.0 (1/64 - 1/16)	OK (J)
	2 steps elastic zigzag		Overcasting (medium weight and stretch fabrics), tape and elastic	5.0 (3/16)	1.5 - 7.0 (1/16 - 1/4)	1.0 (1/16)	0.2 - 4.0 (1/64 - 1/16)	OK (J)
	3 steps elastic zigzag		Overcasting (medium, heavyweight and stretch fabrics), tape and elastic	5.0 (3/16)	1.5 - 7.0 (1/16 - 1/4)	1.0 (1/16)	0.2 - 4.0 (1/64 - 1/16)	OK (J)

1 Select a stitch.

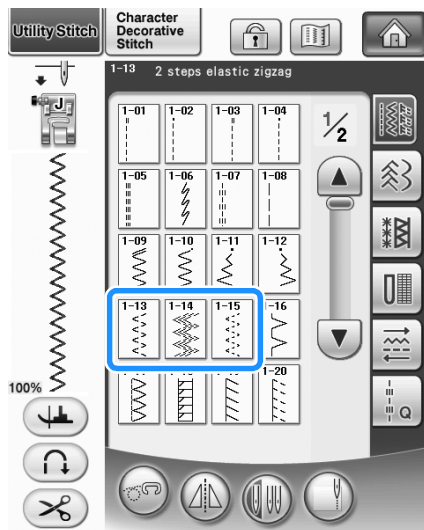

2 Attach presser foot "J".

■ Tape Attaching

Stretch the tape flat. While stretching the tape flat, sew the tape to the fabric.

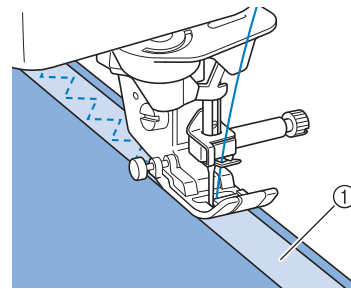

① Tape

■ Overcasting

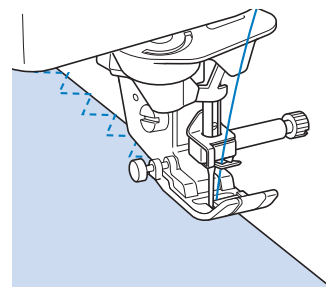

Use this stitch to sew overcasting on the edge of stretch fabrics. Sew the overcasting along the edge of the fabric while positioning the right-hand side needle drop point just outside the edge of the fabric.



Overcasting

Use for the edge of seams in skirts or trousers, and the edge of all cuttings. Use presser foot “G”, presser foot “J”, or the side cutter attachment depending on the kind of overcasting stitch you select.

Overcasting Using Presser Foot “G”

Stitch	Stitch name	Presser foot	Applications	Stitch width [mm (inch)]		Stitch length [mm (inch)]		Twin needle
				Auto	Manual	Auto	Manual	
1-16	Overcasting stitch		Reinforcing of light and medium weight fabrics	3.5 (1/8)	2.5 - 5.0 (3/32 - 3/16)	2.0 (1/16)	1.0 - 4.0 (1/16 - 3/16)	NO
1-17	Overcasting stitch		Reinforcing of heavyweight fabric	5.0 (3/16)	2.5 - 5.0 (3/32 - 3/16)	2.5 (3/32)	1.0 - 4.0 (1/16 - 3/16)	NO
1-18	Overcasting stitch		Reinforcing of medium, heavyweight and easily friable fabrics or decorative stitching.	5.0 (3/16)	3.5 - 5.0 (1/8 - 3/16)	2.5 (3/32)	1.0 - 4.0 (1/16 - 3/16)	NO

1 Select a stitch and attach presser foot “G”.

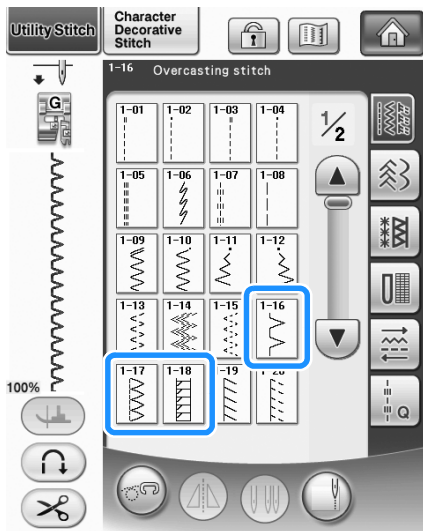

2 Lower the presser foot so that the presser foot guide is set flush against the edge of the fabric.

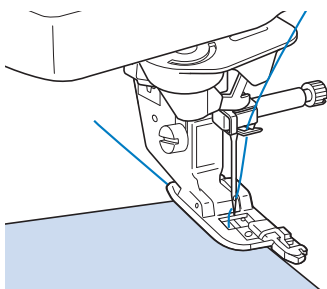

3 Sew along the presser foot guide.

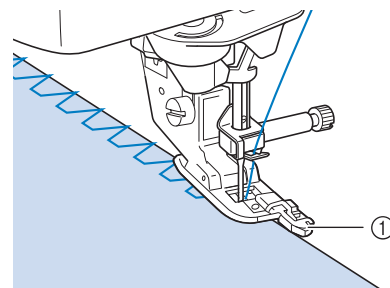

① Guide





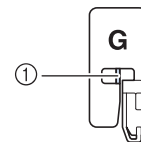







CAUTION

- After the stitch width is adjusted, rotate the handwheel toward you (counterclockwise). Check that the needle does not touch the presser foot. If the needle hits the presser foot, the needle may break and cause injury.



- ① The needle should not touch the center bar
- If the presser foot is raised to its highest level, the needle may strike the presser foot.

Overcasting Using Presser Foot “J”

Stitch	Stitch name	Presser foot	Applications	Stitch width [mm (inch)]		Stitch length [mm (inch)]		Twin needle
				Auto	Manual	Auto	Manual	
	Overcasting stitch		Reinforced seaming of stretch fabric	5.0 (3/16)	0.0 - 7.0 (0 - 9/32)	2.5 (3/32)	0.5 - 4.0 (1/32 - 3/16)	OK (J)
	Overcasting stitch		Reinforcing of medium stretch fabric and heavyweight fabric, decorative stitching	5.0 (3/16)	0.0 - 7.0 (0 - 9/32)	2.5 (3/32)	0.5 - 4.0 (1/32 - 3/16)	OK (J)
	Overcasting stitch		Reinforcement of stretch fabric or decorative stitching	4.0 (3/16)	0.0 - 7.0 (0 - 1/4)	4.0 (3/16)	1.0 - 4.0 (1/16 - 3/16)	OK (J)
	Overcasting stitch		Stretch knit seam	5.0 (3/16)	0.0 - 7.0 (0 - 1/4)	4.0 (3/16)	1.0 - 4.0 (1/16 - 3/16)	NO
	Single diamond overcast		Reinforcement and seaming stretch fabric	6.0 (15/64)	1.0 - 7.0 (1/16 - 1/4)	3.0 (1/8)	1.0 - 4.0 (1/16 - 3/16)	OK (J)
	Single diamond overcast		Reinforcement of stretch fabric	6.0 (15/64)	1.0 - 7.0 (1/16 - 1/4)	1.8 (1/16)	1.0 - 4.0 (1/16 - 3/16)	OK (J)

3

Utility Stitches

1 Select a stitch and attach presser foot “J”.

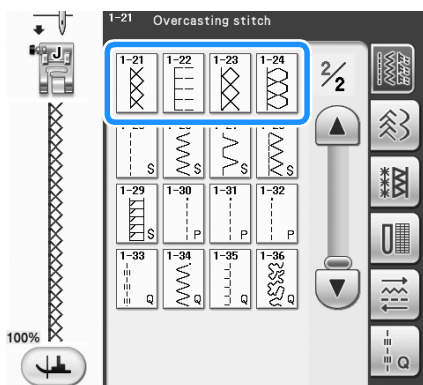
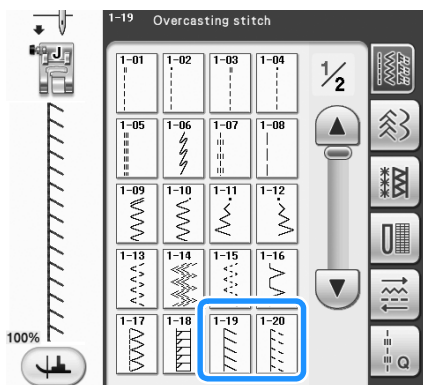

2 Sew with the needle dropping slightly off the edge of the fabric.

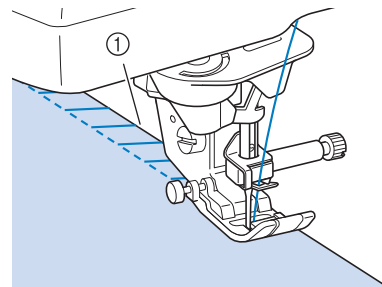

① Needle drop position

Overcasting Using the Side Cutter

By using the side cutter, you can do overcasting while cutting the fabric.











CAUTION

- Recommended stitches are noted "S" in the lower right corner, therefore sure to only select one of these stitches listed below. Using another stitch may cause the needle to hit the presser foot and break, possibly causing injury.



Note

- Thread the needle manually when using the side cutter, or only attach the side cutter after threading the needle using the "Automatic Threading" button.

Stitch	Stitch name	Presser foot	Applications	Stitch width [mm (inch)]		Stitch length [mm (inch)]		Twin needle
				Auto	Manual	Auto	Manual	
	With side cutter		Straight stitch while cutting fabrics	0.0 (0)	0.0 - 2.5 (0 - 3/32)	2.5 (3/32)	0.2 - 5.0 (1/64 - 3/16)	NO
	With side cutter		Zigzag stitch while cutting fabrics	3.5 (1/8)	3.5 - 5.0 (1/8 - 3/16)	1.4 (1/16)	0.0 - 4.0 (0 - 3/16)	NO
	With side cutter		Overcasting stitch while cutting fabrics	3.5 (1/8)	3.5 - 5.0 (1/8 - 3/16)	2.0 (1/16)	1.0 - 4.0 (1/16 - 3/16)	NO
	With side cutter		Overcasting stitch while cutting fabrics	5.0 (3/16)	3.5 - 5.0 (1/8 - 3/16)	2.5 (3/32)	1.0 - 4.0 (1/16 - 3/16)	NO
	With side cutter		Overcasting stitch while cutting fabrics	5.0 (3/16)	3.5 - 5.0 (1/8 - 3/16)	2.5 (3/32)	1.0 - 4.0 (1/16 - 3/16)	NO

1 Select a stitch.

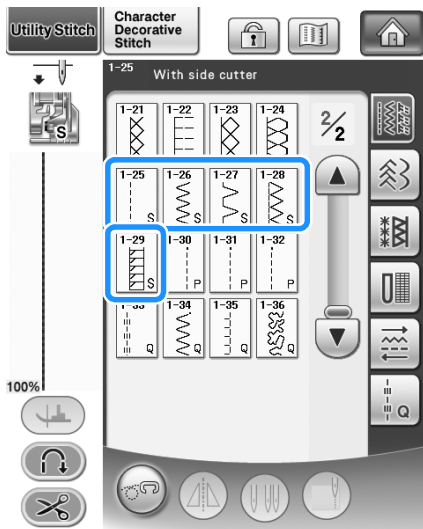

2 Follow the steps on page 54 to remove the presser foot.

3 Thread the needle (see page 46).

4 Position the fork on the side cutter's operating lever onto the needle clamp screw.

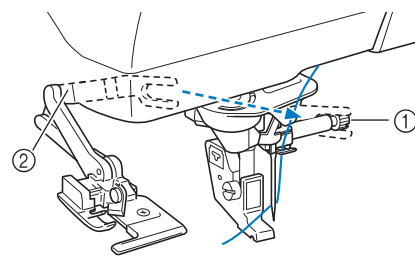

- ① Needle clamp screw
- ② Operating lever

Memo

- Make sure that the fork of the operating lever is set onto the needle screw firmly.

- 5** Position the side cutter so that the side cutter pin is aligned with the notch in the presser foot holder, and then lower the presser foot.

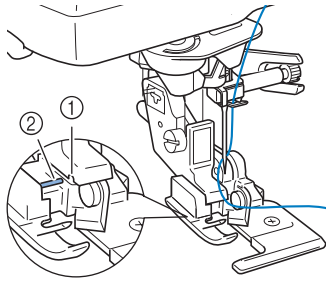

- ① Notch in presser foot holder
 ② Pin
 → The side cutter is attached.

- 6** Raise the presser foot and pull out a long section of the upper thread. Pass it below the presser foot and pull it out in the fabric feed direction.

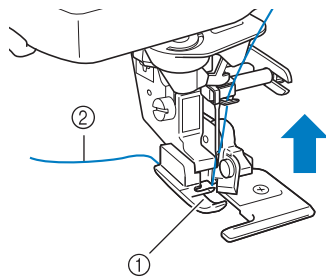

- ① Presser foot
 ② Upper thread

- 7** Make a cut of approximately 20 mm (approx. 3/4 inch) in the fabric.

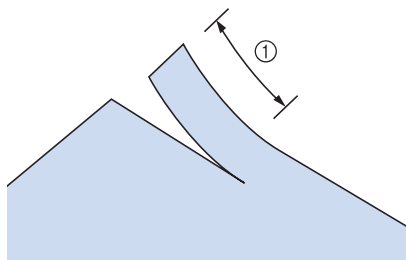

- ① 20 mm (approx. 3/4 inch)

- 8** Position the fabric so that the right side of the cut is on top of the guide plate and the left side of the cut is underneath the presser foot.

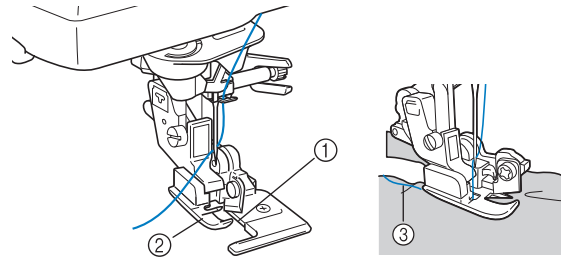

- ① Guide plate (lower knife)
 ② Presser foot
 ③ Upper thread

 **Memo**

- If the fabric is not positioned correctly, the fabric will not be cut.

9 Lower the presser foot and start.

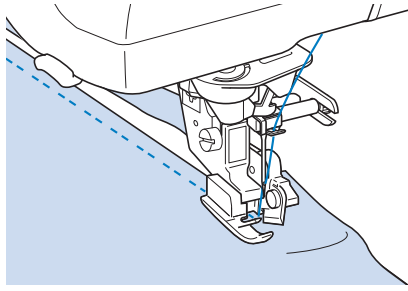

→ A seam allowance is cut while the stitching is sewn.

CAUTION

- When using the side cutter, sew between low and mid-speed and do not touch the knives or operation lever of the side cutter while sewing to avoid equipment damage or injury.

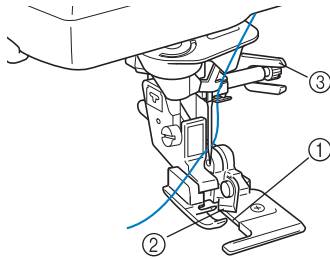

- ① Guide plate (lower knife)
- ② Upper knife
- ③ Operation lever

Note

- If the width has been adjusted, rotate the handwheel toward you (counterclockwise). Check that the needle does not touch the side cutter. If the needle touches the side cutter, it might cause the needle to break.

When Sewing Straight Stitches While Using the Side Cutter

The seam margin should be approximately 5 mm (approx. 3/16 inch).

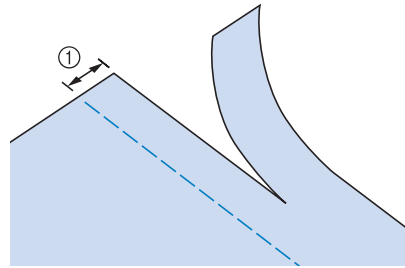

① Seam margin

Memo

- The fabric will not be cut if the whole fabric is simply spread out underneath the presser foot guide plate. Set the fabric as explained in step **8** from the previous section, and then start sewing.

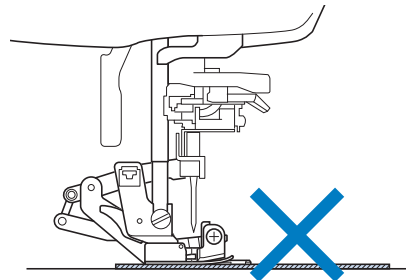

- One layer of 13 oz. denim can be cut.
- Clean the side cutter after use to avoid having dust and scraps of thread build up on it.
- Add a small amount of oil as required to the cutting edge of the cutter.





Quilting

















You can make beautiful quilts quickly and easily with this machine. When making a quilt, you will find it convenient to use the knee lifter and foot controller to free your hands for other tasks (“Using the Foot Controller” on page 61 and/or “Using the Knee Lifter” on page 71).

The 30 quilting stitches Q-01 through Q-30 and the utility stitches with “P” or “Q” indicated on their key are useful for quilting.

The “P” or “Q” at the bottom of the key display indicates that these stitches are intended for (“Q”) quilting and (“P”) piecing.

Stitch	Stitch name	Presser foot		Applications	Stitch width [mm (inch)]		Stitch length [mm (inch)]		Twin needle
					Auto	Manual	Auto	Manual	
	Piecing stitch (Middle)			Piecework/patchwork	—	—	2.0 (1/16)	0.2 - 5.0 (1/64 - 3/16)	NO
	Piecing stitch (Right)			Piecework/patchwork 6.5 mm (approx. 1/4 inch) right seam allowance	5.50 (7/32)	0.00 - 7.00 (0 - 1/4)	2.0 (1/16)	0.2 - 5.0 (1/64 - 3/16)	NO
	Piecing stitch (Left)			Piecework/patchwork 6.5 mm (approx. 1/4 inch) left seam allowance	1.50 (1/16)	0.00 - 7.00 (0 - 1/4)	2.0 (1/16)	0.2 - 5.0 (1/64 - 3/16)	NO
	Hand-look quilting			Quilting stitch made to look like hand quilting stitch	3.50	0.00 - 7.00 (0 - 1/4)	2.5 (3/32)	1.0 - 4.0 (1/16 - 3/16)	NO
	Basting stitch			Basting	3.50	0.00 - 7.00 (0 - 1/4)	20 (3/4)	5 - 30 (3/16 - 1-3/16)	NO
	Stem stitch			Reinforced stitching, sewing and decorative applications	1.00 (1/16)	1.00 - 3.00 (1/16 - 1/8)	2.5 (3/32)	1.0 - 4.0 (1/16 - 3/16)	NO
	Quilting appliqué zigzag stitch			Zigzag stitch for quilting and sewing on appliqué quilt pieces	3.50 (1/8)	0.00 - 7.00 (0 - 1/4)	1.6	0.0 - 4.0 (0 - 3/16)	NO
	Zigzag stitch (Right)			Start from right needle position, zigzag sew at left	3.50 (1/8)	2.50 - 5.00 (3/32 - 3/16)	1.6	0.3 - 4.0 (1/64 - 3/16)	NO
	Zigzag stitch (Left)			Start from left needle position, zigzag sew at right	3.50 (1/8)	2.50 - 5.00 (3/32 - 3/16)	1.6	0.3 - 4.0 (1/64 - 3/16)	NO
	2 steps elastic zigzag			Overcasting (medium weight and stretch fabrics), tape and elastic	5.00 (3/16)	1.50 - 7.00 (1/16 - 1/4)	1.0 (1/16)	0.2 - 4.0 (1/64 - 1/16)	NO
	3 steps elastic zigzag			Overcasting (medium, heavyweight and stretch fabrics), tape and elastic	5.00 (3/16)	1.50 - 7.00 (1/16 - 1/4)	1.0 (1/16)	0.2 - 4.0 (1/64 - 1/16)	NO
	Quilting appliqué stitch			Quilting stitch for invisible appliqué or attaching binding	2.00	0.50 - 5.00 (1/64 - 3/16)	2.0	1.0 - 4.0 (1/16 - 3/16)	NO
	Shell tuck edge			Shell tuck edge finish on fabrics	4.00 (3/16)	0.00 - 7.00 (0 - 1/4)	2.5 (3/32)	0.2 - 4.0 (1/64 - 1/16)	NO
	Blanket stitch			Appliqués, decorative blanket stitch	3.50 (1/8)	2.50 - 7.00 (3/32 - 1/4)	2.5 (3/32)	1.6 - 4.0 (1/16 - 3/16)	NO

Stitch	Stitch name	Presser foot		Applications	Stitch width [mm (inch)]		Stitch length [mm (inch)]		Twin needle
					Auto	Manual	Auto	Manual	
	Quilting stippling			Background quilting	7.00 (1/4)	1.00 - 7.0 (1/16 - 1/4)	1.6 (1/16)	1.0 - 4.0 (1/16 - 3/16)	NO
	Overcasting stitch			Stretch knit seam	5.00 (3/16)	0.00 - 7.00 (0 - 1/4)	4.0 (3/16)	1.0 - 4.0 (1/16 - 3/16)	NO
	Tape attaching			Attaching tape to seam in stretch fabric	5.50	0.00 - 7.00 (0 - 1/4)	1.4	0.2 - 4.0 (1/61 - 3/16)	NO
	Serpentine stitch			Decorative stitching and attaching elastic	5.00 (3/16)	1.50 - 7.00 (1/16 - 1/4)	2.0	0.2 - 4.0 (1/64 - 3/16)	NO
	Feather stitch			Fagoting, decorative stitching	5.00 (3/16)	0.00 - 7.00 (0 - 1/4)	2.5 (3/32)	1.0 - 4.0 (1/16 - 3/16)	NO
	Fagoting cross stitch			Fagoting, bridging and decorative stitching	5.00 (3/16)	2.50 - 7.00 (3/32 - 1/4)	2.5 (3/32)	1.0 - 4.0 (1/16 - 3/16)	NO
	Couching stitch			Decorative stitching, attaching cord and couching	5.00 (3/16)	0.00 - 7.00 (0 - 1/4)	1.2 (1/16)	0.2 - 4.0 (1/64 - 1/16)	NO
	Patchwork double overlock stitch			Patchwork stitches, decorative stitching	5.00 (3/16)	2.50 - 7.00 (3/32 - 1/4)	2.5 (3/32)	1.0 - 4.0 (1/16 - 3/16)	NO
	Smocking stitch			Smocking, decorative stitching	5.00 (3/16)	0.00 - 7.00 (0 - 1/4)	1.6 (1/16)	1.0 - 4.0 (1/16 - 3/16)	NO
	Rick-rack stitch			Decorative top stitching	4.00 (3/16)	0.00 - 7.00 (0 - 1/4)	2.5 (3/32)	1.0 - 4.0 (1/16 - 3/16)	NO
	Decorative stitch			Decorative stitching and appliqué	6.00 (15/64)	1.00 - 7.00 (1/16 - 1/4)	1.0 (1/16)	0.2 - 4.0 (1/64 - 3/16)	NO
	Decorative stitch			Decorative stitching	5.50 (3/16)	0.00 - 7.00 (0 - 1/4)	1.6 (1/16)	1.0 - 4.0 (1/16 - 3/16)	NO
	Hemstitching			Heirloom, decorative hems	5.00 (3/16)	1.50 - 7.00 (1/16 - 1/4)	2.0 (1/16)	1.5 - 4.0 (1/16 - 3/16)	NO
	Hemstitching			Decorative hems and bridging stitch	6.00 (15/64)	1.50 - 7.00 (1/16 - 1/4)	2.0 (1/16)	1.5 - 4.0 (1/16 - 3/16)	NO
	Single diamond overcast			Reinforcement and seaming stretch fabric	6.00 (15/64)	1.00 - 7.00 (1/16 - 1/4)	3.0 (1/8)	1.0 - 4.0 (1/16 - 3/16)	NO
	Overcasting stitch			Reinforcement of stretch fabric or decorative stitching	4.00 (3/16)	0.00 - 7.00 (0 - 1/4)	4.0 (3/16)	1.0 - 4.0 (1/16 - 3/16)	NO
	Piecing stitch (Right)			Piecework/patchwork 6.5 mm (approx. 1/4 inch) left seam allowance	5.5 (7/32)	0.0 - 7.0 (0 - 1/4)	2.0 (1/16)	0.2 - 5.0 (1/64 - 3/16)	NO
	Piecing stitch (Middle)			Piecework/patchwork	—	—	2.0 (1/16)	0.2 - 5.0 (1/64 - 3/16)	NO

Stitch	Stitch name	Presser foot		Applications	Stitch width [mm (inch)]		Stitch length [mm (inch)]		Twin needle
					Auto	Manual	Auto	Manual	
	Piecing stitch (Left)			Piecing/patchwork 6.5 mm (approx. 1/4 inch) left seam allowance	1.5 (1/16)	0.0 - 7.0 (0 - 1/4)	2.0 (1/16)	0.2 - 5.0 (1/64 - 3/16)	NO
	Hand-look quilting			Quilting stitch made to look like hand quilting stitch	0.0 (0)	0.0 - 7.0 (0 - 1/4)	2.5 (3/32)	1.0 - 4.0 (1/16 - 3/16)	NO
	Quilting appliqué zigzag stitch			Zigzag stitch for quilting and sewing on appliqué quilt pieces	3.5 (1/8)	0.0 - 7.0 (0 - 1/4)	1.4 (1/16)	0.0 - 4.0 (0 - 3/16)	NO
	Quilting appliqué stitch			Quilting stitch for invisible appliqué or attaching binding	1.5 (1/16)	0.5 - 5.0 (1/64 - 3/16)	1.8 (1/16)	1.0 - 4.0 (1/16 - 3/16)	NO
	Quilting stippling			Background quilting	7.0 (1/4)	1.0 - 7.0 (1/16 - 1/4)	1.6 (1/16)	1.0 - 4.0 (1/16 - 3/16)	NO

**Memo**



- When a stitch pattern in the Quilting Stitches category (Q-02 through Q-30) is selected, a finer stitch width can be set than is available with stitch patterns in other categories. For example: Stitch Q-03 has 57 needle positions and stitch Q-19 has 29 width selections.

**Note**

- The width range of stitch setting is only available in the Quilting stitch "Q" quilting category.

■ Piecing

Sewing two pieces of fabric together is called piecing. When cutting pieces for quilt blocks, make sure the seam allowance is 6.5 mm (approx. 1/4 inch).

1 Select  or  and attach presser foot “J”.

2 Align the edge of the fabric with the edge of the presser foot, and start sewing.

* To sew a 6.5 mm (approx. 1/4 inch) seam allowance

along the left edge of the presser foot with 

selected, the width should be set to 5.50 mm (approx. 7/32 inch).

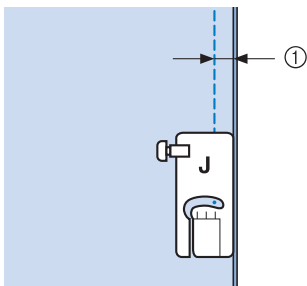

① 6.5 mm (approx. 1/4 inch)



* To sew a 6.5 mm (approx. 1/4 inch) seam allowance

along the left edge of the presser foot with 

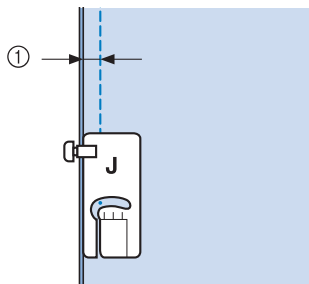
selected, the width should be set to 1.50 mm (approx. 1/32 inch).



① 6.5 mm (approx. 1/4 inch)

* To change the needle position, use  or  in the width display.

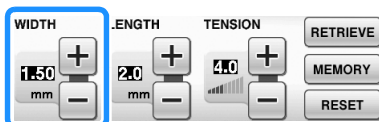

Memo

- Using a straight stitch (middle needle position) makes it easier to sew smoothly (see page 83).

■ Quilting

Sewing the quilt top, batting, and backing together is called quilting. You can sew the quilt with the walking foot to keep the quilt top, batting, and backing from sliding. The walking foot has a set of feed dogs that move together with the feed dogs in the needle plate during sewing.

For straight line quilting, use the walking foot and the straight stitch needle plate. Always select a straight stitch (middle needle position) when using the straight stitch needle plate.

1 Select ,  or .

2 Attach the walking foot (see page 55).

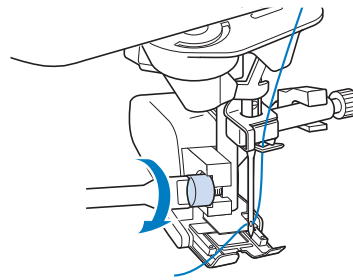

Note

- Thread the needle manually when using the walking foot, or only attach the walking foot after threading the needle using the “Automatic Threading” button.

3 Place one hand on each side of the presser foot to hold the fabric secure while sewing.

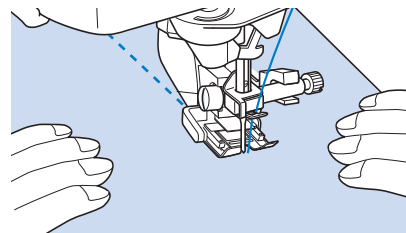

Memo

- Sew at slow to medium speed.
- Do not sew in reverse or use stitches that require side ways or reverse feeding. Always check to be sure that your quilting surface is securely basted before beginning to sew. Specialized machine quilt needles and threads are also available for machine quilting.

■ Appliqué

- 1 Trace the pattern onto the appliqué fabric and then cut around it, leaving a 3 to 5 mm (approx. 1/8 to 3/16 inch) seam allowance.

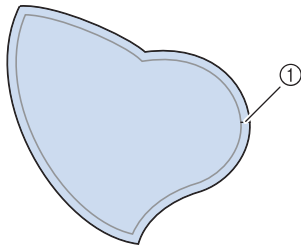

① Seam allowance: 3 to 5 mm (approx. 1/8 to 3/16 inch)

- 2 Place a piece of stabilizer cut to the finished size of the appliqué design onto the fabric, and then fold over the seam margin using an iron. Clip curves when necessary.

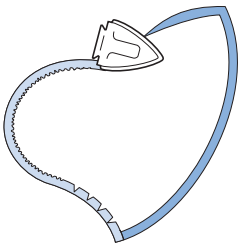

- 3 Turn the appliqué over, and attach the stabilizer with basting pins or a basting stitch.

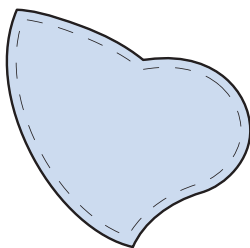

- 4 Select  and attach presser foot "J".

- 5 Use the quilting appliqué stitch to attach the appliqué. Sew around the edge while dropping the needle as close to the edge as possible.

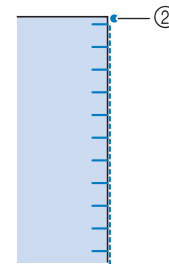
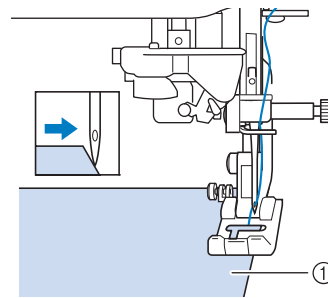
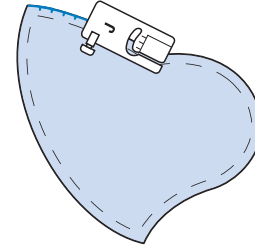

- ① Appliqué
② Needle drop position

⚠ CAUTION

- Be careful that the needle does not strike a basting pin during sewing. Striking a pin can cause the needle to break, resulting in injury.

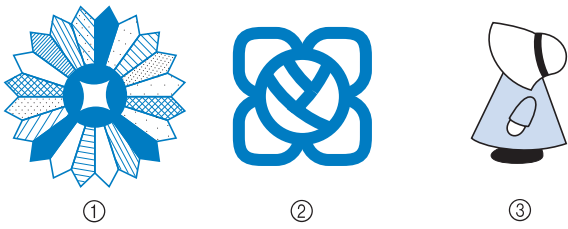

You can use the appliqué technique to attach appliqué designs like the three pictured below.



- ① Dresden plate
- ② Stained glass
- ③ Sunbonnet sue

■ Quilting with Satin Stitches

For better fabric control, use the foot controller to sew with satin stitches. Set the speed control slide to control the stitch width to make subtle changes in the stitch width during sewing.

- 1 Attach the foot controller (see page 61).
- 2 Select  and attach presser foot “J”.
- 3 Press  in the length display to shorten the stitch length.

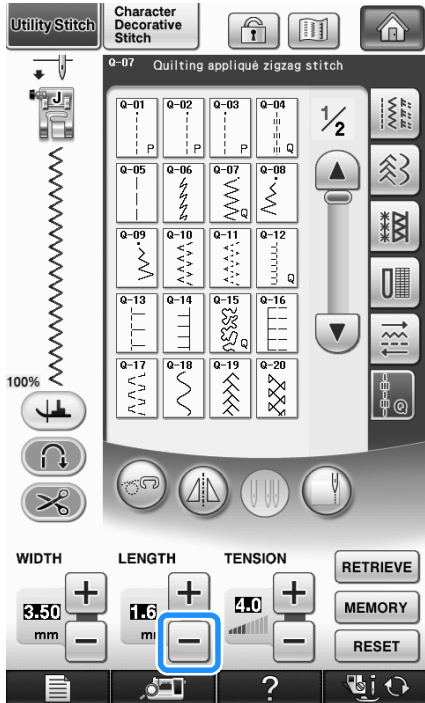

Memo

- The setting will vary according to the kind of fabric and the thickness of the thread, but a length of 0.3 to 0.5 mm (approx. 1/64 to 1/32 inch) is best for satin stitches.

- 4 Press  to use the speed control slide to control the stitch width.
- 5 Set the width control to “ON”.

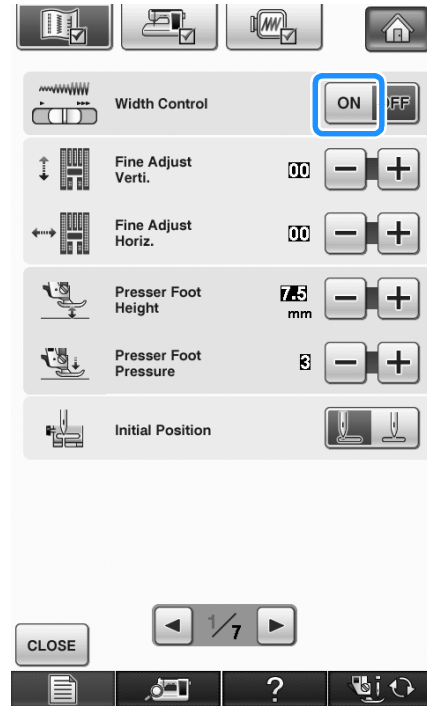

Memo

- You can use the speed control slide to adjust the stitch width. Use the foot controller to adjust the sewing speed.

- 6 Press  .
→ The display will return to the original screen.
- 7 Start sewing.
* You can adjust the stitch width during sewing by moving the sewing speed controller. Slide the lever to the left, and the stitch width becomes narrower. Slide it to the right, the stitch width becomes wider. The size of the width changes equally on both sides of the middle needle position.

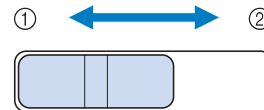

- ① narrower
- ② wider

Example: Changing the width

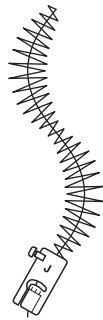

- 8** When you are finished sewing, set the width control back to “OFF”.

Free Motion Quilting

With free motion quilting, the feed dogs can be lowered by pressing , so that the fabric can be moved freely in any direction.

For free motion quilting, use free motion quilting foot “C” or free motion open toe quilting foot “O” depending on the stitch that is selected, and set the machine to free motion sewing mode. In this mode, the presser foot is raised to the necessary height for free motion sewing.

We recommend attaching the foot controller and sewing at a consistent speed. You can adjust the sewing speed with the speed control slide on the machine.

Using Free motion Quilting Foot “C”

Use the free motion quilting foot “C” with straight stitch needle plate for free motion sewing.



Free motion quilting foot “C”



CAUTION

- With free motion quilting, control the feeding speed of the fabric to match the sewing speed. If the fabric is moved faster than the sewing speed, the needle may break or other damage may result.
- When using free motion quilting foot “C”, be sure to use the straight stitch needle plate and sew with the needle in middle (center) needle position. If the needle is moved to any position other than the middle (center) needle position, the needle may break, which may result in injuries.

Memo

- When starting to sew, the internal sensor detects the thickness of the fabric, and the quilting foot is raised to the height specified in the machine settings screen. Press

 to display “Free Motion Foot Height” on 2/7 of the settings screen. Press

 or  to select the height that the quilting foot is raised above the fabric.

Increase the setting by pressing , for example, when sewing very stretchy fabric, so that it is easier to sew.



- In order to sew with a balanced tension, it may be necessary to adjust the upper thread tension. Test with a sample piece of fabric that is similar to your chosen fabric.

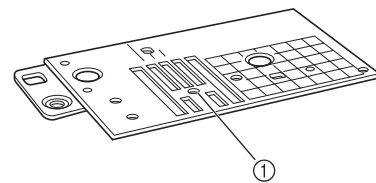

- 1** Attach the straight stitch needle plate (see page 86).



① Round hole

Memo

- Notice this needle plate has a round hole for the needle.

- 2** Select  or .

- 3** Press  to set the machine to free motion sewing mode.

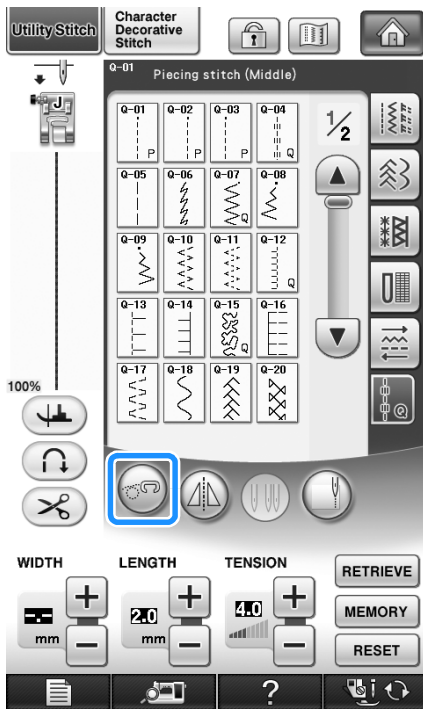

→ The key appears as , the quilting foot is raised to the necessary height, and then the feed dogs are lowered for free motion sewing.

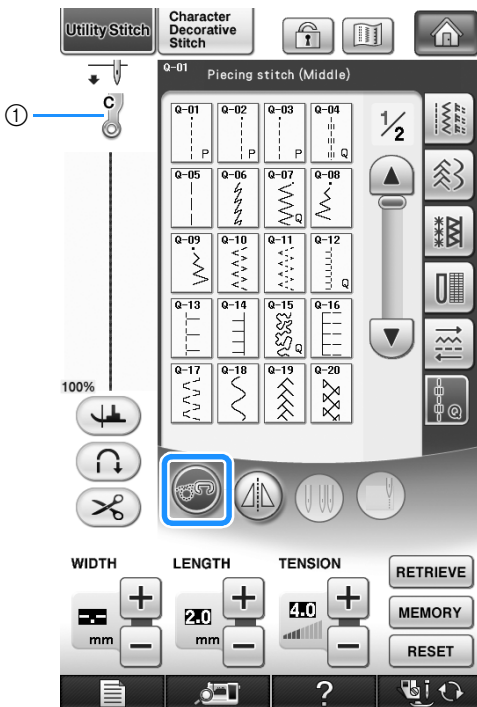

- ① Free motion quilting foot “C”
 → When stitch Q-01 or 1-31 is selected, free motion quilting foot “C” is indicated in the upper-left corner of the screen.

- 4** Remove the presser foot holder (see page 55).

- 5** Attach free motion quilting foot “C” at the front with the presser foot holder screw aligned with the notch in the quilting foot.

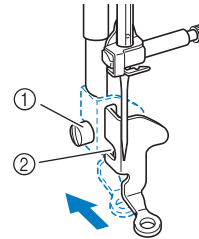

- ① Presser foot holder screw
 ② Notch

Note
 • Make sure that the quilting foot is attached properly and not slanted.

- 6** Hold the quilting foot in place with your right hand, and tighten the presser foot holder screw using the screwdriver with your left hand.

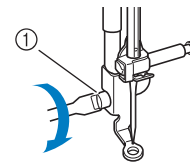

- ① Presser foot holder screw

CAUTION
 • Be sure to securely tighten the screws with the included screwdriver. Otherwise, the needle may touch the quilting foot, causing it to bend or break.

- 7** Use both hands to stretch the fabric taut, and then move the fabric at a consistent pace in order to sew uniform stitches roughly 2.0-2.5 mm (approx. 1/16 - 3/32 inch) in length.

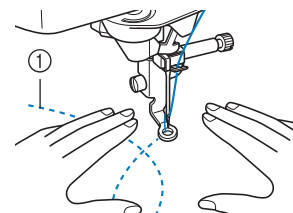

- ① Stitch

8 Press to cancel the free motion sewing mode.

→ Rotate the handwheel toward you (counterclockwise) to raise the feed dogs.

9 After sewing, make sure to remove the straight stitch needle plate and presser foot “C”, and reinstall the regular needle plate and the needle plate cover.



Note

- Free motion open toe quilting foot “O” can also be used with the straight stitch needle plate. We recommend using free motion open toe quilting foot “O” with free motion sewing of fabrics of uneven thicknesses.
- When using the straight stitch needle plate, all straight stitches become middle needle position stitches. You cannot change the needle position using the width display.



Memo

- Normally, the feed dogs are raised for regular sewing.
- Do not be discouraged with your initial results. The technique requires practice.

Using free motion Open Toe Quilting Foot “O”

The free motion open toe quilting foot “O” is used for free motion quilting with zigzag or decorative stitches or for free motion quilting of straight lines on fabric with an uneven thickness. Various stitches can be sewn using free motion open toe quilting foot “O”. For details on the stitches that can be used, refer to the “STITCH SETTING CHART” at the end of this manual.

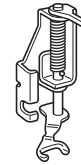

Free motion open toe quilting foot “O”



Memo

- In order to sew with a balanced tension, it may be necessary to adjust the upper thread tension (see page 67). Test with a sample piece of quilting fabric.

1 Press to set the machine to free motion sewing mode.

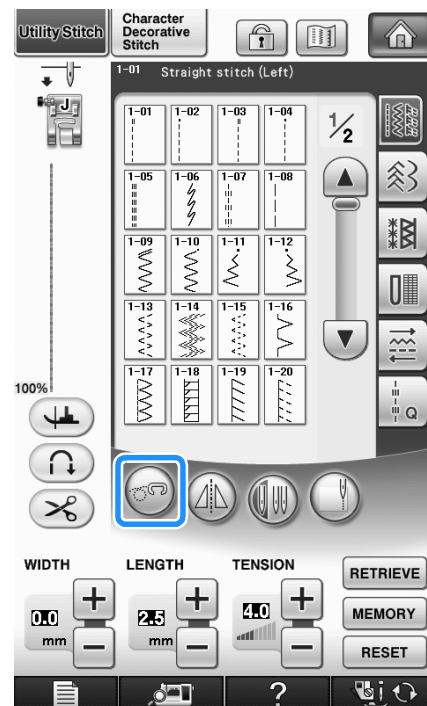

→ The key appears as , the quilting foot is raised to the necessary height, and then the feed dogs are lowered for free motion sewing.

2 Select a stitch.

Memo

- When stitch Q-01 or 1-31 is selected, free motion quilting foot “C” is indicated in the upper-left corner of the screen. When the other stitches are selected, free motion open toe quilting foot “O” is indicated in the screen.

3 Remove the presser foot holder (see page 55).

4 Attach free motion open toe quilting foot “O” by positioning the pin of the quilting foot above the needle clamp screw and aligning the lower-left of the quilting foot and the presser bar.

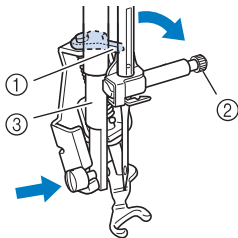

- ① Pin
- ② Needle clamp screw
- ③ Presser bar

Note

- Make sure that the quilting foot is not slanted.

5 Hold the quilting foot in place with your right hand, and tighten the presser foot holder screw using the screwdriver with your left hand.

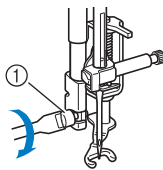

- ① Presser foot holder screw

CAUTION

- Be sure to securely tighten the screws with the included screwdriver. Otherwise, the needle may touch the quilting foot, causing it to bend or break.

6 Use both hands to stretch the fabric taut, and then move the fabric at a consistent pace in order to sew uniform stitches roughly 2.0-2.5 mm (approx. 1/16 - 3/32 inch) in length.

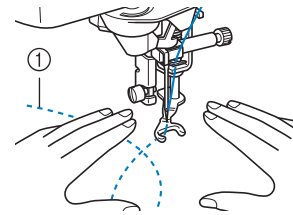

- ① Stitch

7 Press  to cancel the free motion sewing mode.

- Rotate the handwheel toward you (counterclockwise) to raise the feed dogs.

Memo

- Do not be discouraged with your initial results. The technique requires practice.

Echo Quilting Using the Free Motion Echo Quilting Foot “E”

Sewing quilting lines at equal distances around a motif is called echo quilting. The quilting lines, which appear as ripples echoing away from the motif, are the distinguishing characteristic of this quilting style. Use the free motion echo quilting foot “E” for echo quilting. Using the measurement on the presser foot as a guide, sew around the motif at a fixed interval. We recommend attaching the foot controller and sewing at a consistent speed.

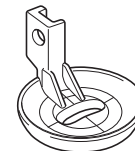

Free motion echo quilting foot “E” measurement

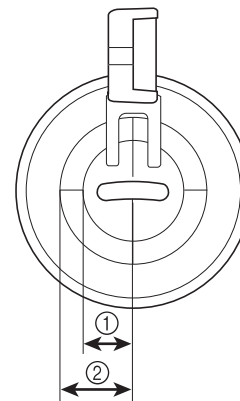





- ① 6.4 mm (approx. 1/4 inch)
- ② 9.5 mm (approx. 3/8 inch)

CAUTION

- With free motion quilting, control the feeding speed of the fabric to match the sewing speed. If the fabric is moved faster than the sewing speed, the needle may break or other damage may result.

Memo

- When starting to sew, the internal sensor detects the thickness of the fabric, and the quilting foot is raised to the height specified in the machine settings screen. Press  to display "Free Motion Foot Height" on 2/7 of the settings screen (see page 22). Press  or  to select the height that the quilting foot is raised above the fabric. Increase the setting by pressing , for example, when sewing very soft fabric, so that it is easier to sew.



- In order to sew with a balanced tension, it may be necessary to adjust the upper thread tension (see page 67). Test with a sample piece of quilting fabric.

1 Select .

2 Press  to set the machine to free motion sewing mode.

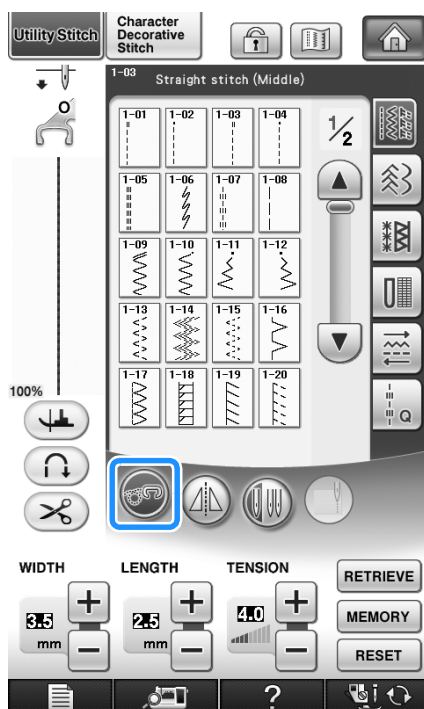

→ The key appears as , the quilting foot is raised to the necessary height, then the feed dogs are lowered for free motion sewing.

3 Follow the steps on page 54 "Removing the Presser Foot" to remove the presser foot.

4 Remove the presser foot holder (see page 55) and the screw.

5 Position the free motion echo quilting foot "E" on the left side of the presser bar with the holes in the quilting foot and presser bar aligned.

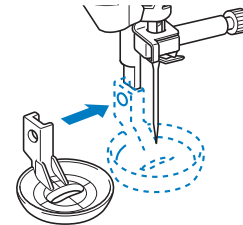

6 Tighten the screw with the included screwdriver.

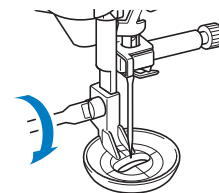
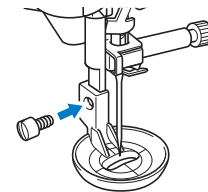

CAUTION

- Be sure to securely tighten the screws with the included screwdriver. Otherwise, the needle may touch the quilting foot, causing it to bend or break.

- 7** Using the measurement on the quilting foot as a guide, sew around the motif.

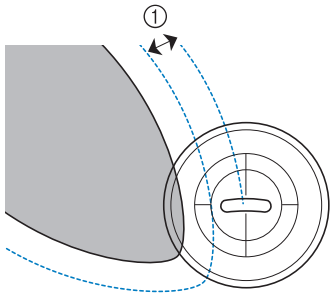
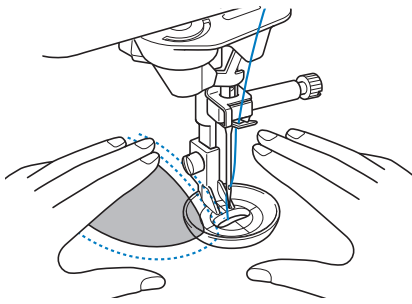

① 6.4 mm (approx. 1/4 inch)

Finished project

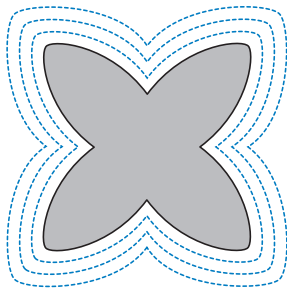



- 8** Press  to cancel the free motion sewing mode.

→ Rotate the handwheel toward you (counterclockwise) to raise the feed dogs.

Blind Hem Stitches

Secure the bottoms of skirts and pants with a blind hem. Two stitches are available for blind hem stitching.

Stitch	Stitch name	Presser foot	Applications	Stitch width [mm (inch)]		Stitch length [mm (inch)]		Twin needle
				Auto	Manual	Auto	Manual	
2-01	Blind hem stitch		Blind hem stitching on mediumweight fabrics	0.0 (0)	+3.0 - -3.0 (+1/8 - -1/8)	2.0 (1/16)	1.0 - 3.5 (1/16 - 1/8)	NO
2-02	Blind hem stitch stretch		Blind hem stitching on stretch fabrics	0.0 (0)	+3.0 - -3.0 (+1/8 - -1/8)	2.0 (1/16)	1.0 - 3.5 (1/16 - 1/8)	NO

Sew a blind hem according to the following procedure.

Memo

- When the size of cylindrical pieces is too small to slide onto the arm or the length is too short, the fabric will not feed and desired results may not be achieved.

1 Turn the skirt or pants wrong side out.



- ① Right side of fabric
- ② Bottom edge of fabric

2 Fold the fabric along the desired edge of the hem, and press.

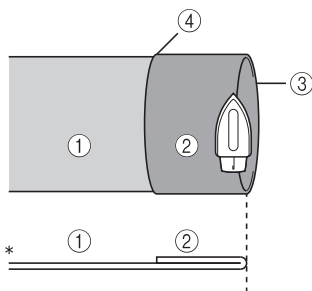

- * Seen from the side
- ① Wrong side of fabric
- ② Right side of fabric
- ③ Folded edge of hem
- ④ Bottom edge of fabric

3 Use a chalk to mark on the fabric about 5 mm (3/16 inch) from the edge of the fabric, and then baste it.

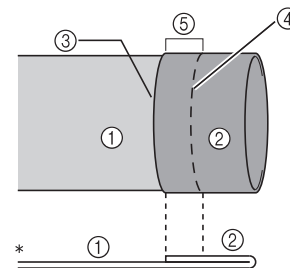

- * Seen from the side
- ① Wrong side of fabric
- ② Right side of fabric
- ③ Edge of fabric
- ④ Basting stitching
- ⑤ 5 mm (3/16 inch)

4 Fold back the fabric inside along the basting line.

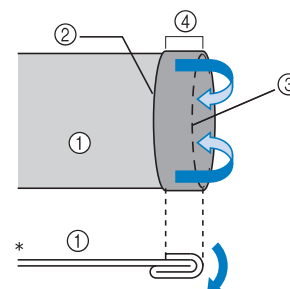

- * Seen from the side
- ① Wrong side of fabric
- ② Edge of fabric
- ③ Basting line
- ④ 5 mm (3/16 inch)

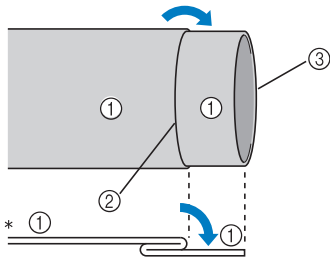

5 Unfold the edge of fabric, and position the fabric with the wrong side facing up.

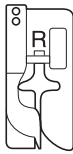

- * Seen from the side
- ① Wrong side of fabric
- ② Basting line
- ③ Bottom edge of fabric

6 Attach blind hem foot "R".



7 Select  or .

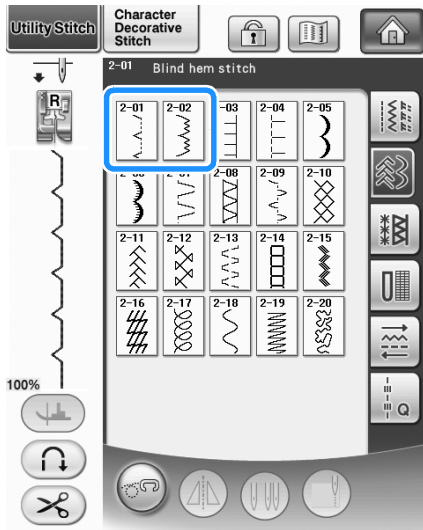

8 Remove the flat bed attachment to use the free-arm.

9 Slide the item that you wish to sew onto the free arm, make sure that the fabric feeds correctly, and then start sewing.

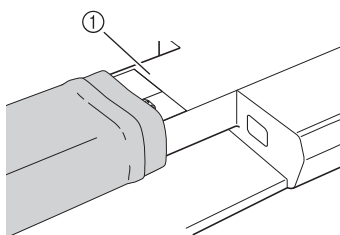

- ① Free arm

10 Position the fabric with the edge of the folded hem against the guide of the presser foot, and then lower the presser foot lever.

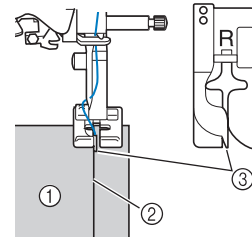

- ① Wrong side of fabric
- ② Fold of hem
- ③ Guide

11 Adjust the stitch width until the needle slightly catches the fold of the hem.

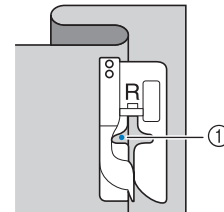

- ① Needle drop point
- When you change the needle drop point, raise the needle, and then change the stitch width.

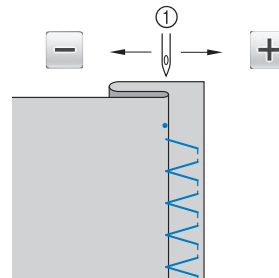

- ① Stitch width

Memo

- Blind hem stitches cannot be sewn if the left needle drop point does not catch the fold. If the needle catches too much of the fold, the fabric cannot be unfolded and the seam appearing on the right side of the fabric will be very large, leaving an unattractive finish. If you experience either of these cases, follow the instructions below to solve the problem.

■ If the Needle Catches Too Much of the Hem Fold

The needle is too far to the left.

Press **+** to decrease the stitch width so that the needle slightly catches the fold of the hem.

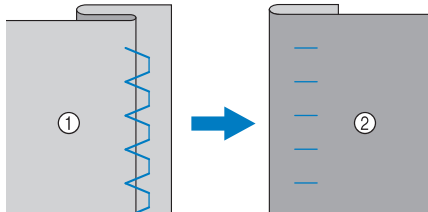

- ① Wrong side of fabric
- ② Right side of fabric

■ If the Needle does not Catch the Hem Fold

The needle is too far to the right.

Press **-** to increase the stitch width so that the needle slightly catches the fold of the hem.

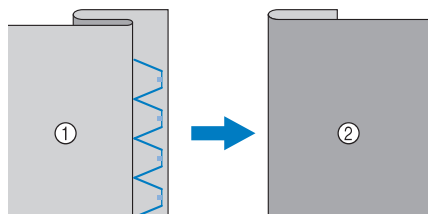

- ① Wrong side of fabric
- ② Right side of fabric

12 Sew with the fold of the hem against the presser foot guide.

13 Remove the basting stitching and reverse the fabric.

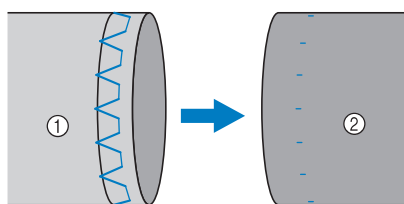

- ① Wrong side of fabric
- ② Right side of fabric



Appliqué

1 Use a temporary spray adhesive, fabric glue or a basting stitch to attach the appliqué to the fabric.

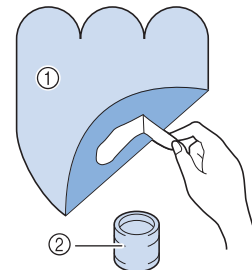
* This will keep the fabric from moving during sewing.



- ① Appliqué
- ② Fabric glue

2 Select  or .

* Adjust the stitch length and width to correspond to the appliqué shape, size, and quality of material (see page 66).



Memo

- For details on each stitch, refer to the “STITCH SETTING CHART” at the end of this manual.

3 Attach presser foot “J”. Check that the needle drops slightly off the edge of the appliqué, then start sewing.

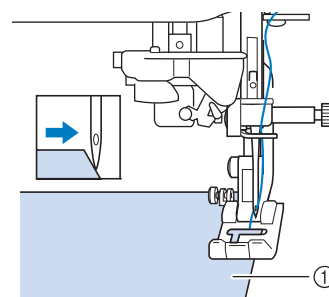

- ① Appliqué material

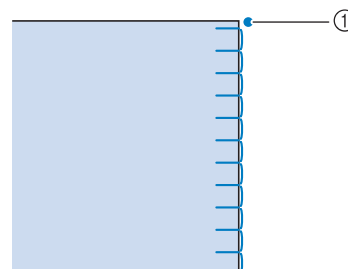

- ① Needle drop position

■ Appliqué Sharp Curves

Stop the machine with the needle in the fabric outside the appliqué. Raise the presser foot and turn the fabric a little bit at a time while sewing for an attractive finish to the seam.

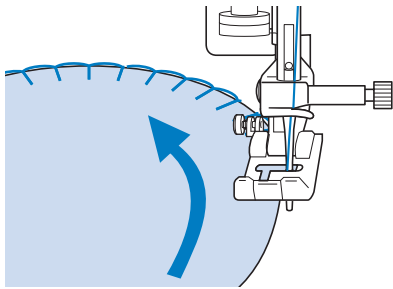

■ Appliqué Corners

Stop the machine with the needle in the right position of the outside (or inside) corner of the appliqué. Raise the presser foot and pivot the fabric to align the fabric edge. Lower the presser foot and continue stitching.

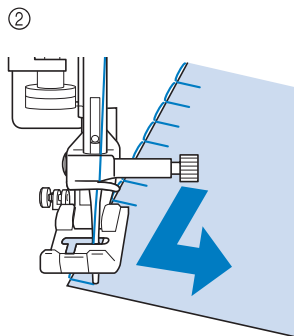
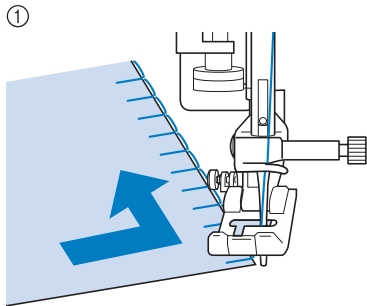

- ① Outside corner
- ② Inside corner

Memo

- Placing a lightweight tear away stabilizer beneath the stitching area will improve the stitch placement along the edge of the appliqué fabric.

Shelltuck Stitches

Shelltuck stitches give an attractive appearance of shells along the curve of a collar. This stitch pattern can be used for edging the neckline or sleeves of dresses and blouses.

- 1 Select  .



Memo

- For details on each stitch, refer to the “STITCH SETTING CHART” at the end of this manual.

- 2 Increase the upper thread tension for an attractive scallop finish to the shelltuck stitches (see page 67).



Memo

- If the upper thread tension is too weak, the shelltuck stitches will not scallop.

- 3 To make rows of shell tuck stitches, fold the fabric in half along the bias.

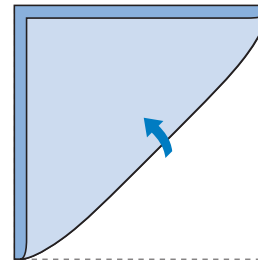

Memo

- Use a thin fabric.

- 4** Attach presser foot “J”. Set the needle drop point slightly off the edge of the fabric, and start sewing.

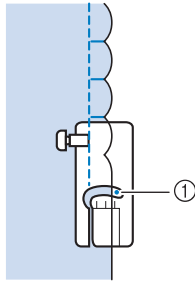
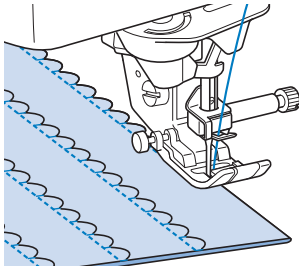

① Needle drop position

- 5** Unfold the fabric, and iron the tucks to one side.

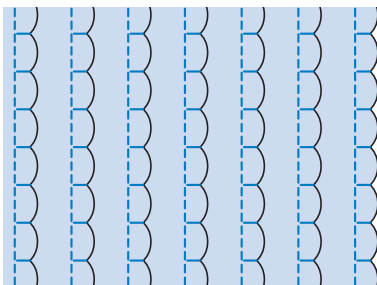

Memo

- To make shell tucks at the edge of a collar or neckline, follow the pattern's instructions and then use this stitch to make a decorative finish on the collar or neckline.

Scallop Stitches

This wave-shaped satin stitch is called the scallop stitch. Use this stitch to decorate the edges of blouse collars and handkerchiefs or use it as a hem accent.



Memo

- A temporary spray adhesive may be necessary for lightweight fabrics. Test sew the fabric before sewing a project.

- 1** Select .



Memo

- For details on each stitch, refer to the “STITCH SETTING CHART” at the end of this manual.

- 2** Attach presser foot “N”. Sew scallop stitches along the edge of the fabric.

* Do not sew directly on the edge of the fabric.

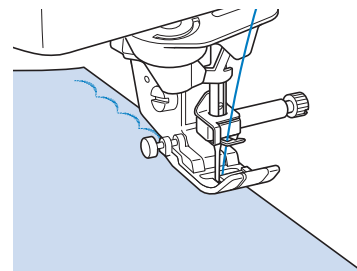

- 3** Trim along the seam, making sure not to cut the stitches.

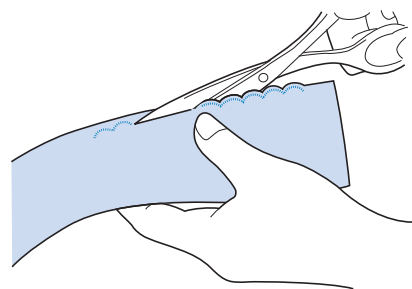

Memo

- Use a seam sealant to secure the edges of the scallop stitches.

Crazy Quilting

For a decorative look called “Crazy Quilting”, the following stitches can be sewn on top of a pressed seam allowance.

- 1 Select a straight stitch and attach presser foot “J”.
- 2 With the right sides facing each other, sew two pieces of fabric together, and then press open the seam allowance.

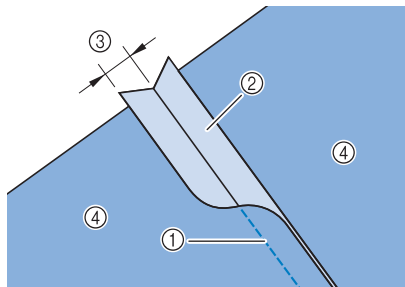

- ① Straight stitch
- ② Seam margins
- ③ 6.5 mm (approx. 1/4 inch)
- ④ Wrong side

- 3 Select a stitch for top stitching.

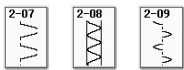

- 4 Place the fabric right side up in the machine, and center the presser foot over the seam when sewing.

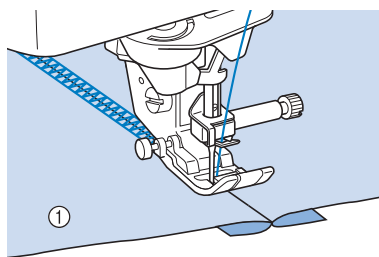

- ① Right side of fabric

Smocking Stitches

Use smocking stitches for decorative sewing on clothes, etc.

- 1 Select a straight stitch and attach presser foot “J”.
- 2 Set the stitch length to 4.0 mm (approx. 3/16 inch) and loosen the upper thread tension to approximately 2.0 (see “Setting the Stitch Length” on page 67 and “Setting the Thread Tension” on page 67).
- 3 Pull the bobbin and upper threads out by 50 mm (approx. 1-15/16 inches).
- 4 Sew the seams, leaving approximately 10 mm (approx. 3/8 inch) between the seams, then trim excess thread, leaving 50 mm (approx. 1-15/16 inches).

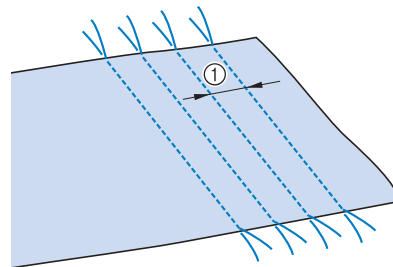

- ① Approximately 10 mm (approx. 3/8 inch)

- 5 Pull the bobbin threads to obtain the desired amount of gather, and then smooth the gathers by ironing them.

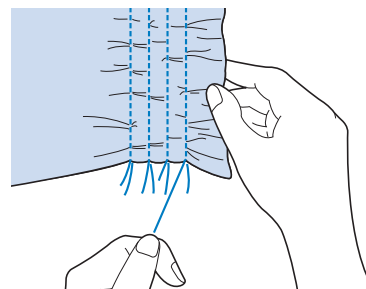

- 6 Select  or  .



Memo

- For details on each stitch, refer to the “STITCH SETTING CHART” at the end of this manual.

- 7** Sew the spaces between the straight seams.

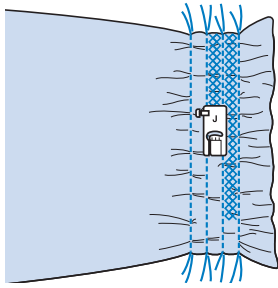

- 8** Pull out the straight stitch threads.

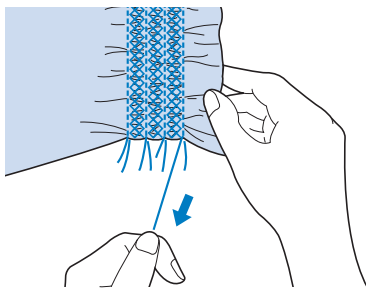

Fagoting



When there is a space between two fabrics with thread sewn over the space to join the fabrics together, it is called fagoting. Use this stitch when sewing blouses or children's clothes.

- 1** Baste two pieces of fabric onto thin paper, leaving a space of 4 mm (approx. 3/16 inch) between the fabrics.

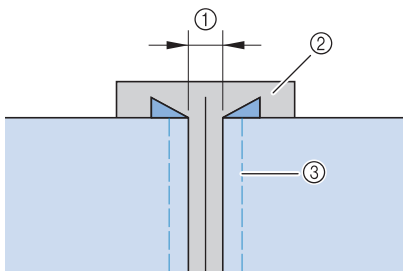
* If you draw a line down the middle of the thin paper or water-soluble stabilizer, sewing is easier.



- ① 4.0 mm (approx. 3/16 inch)
 ② Paper
 ③ Basting stitches

- 2** Select  or .



Memo

- For details on each stitch, refer to the "STITCH SETTING CHART" at the end of this manual.

- 3** Attach presser foot "J". Align the center of the presser foot with the middle of the space between the fabrics and begin sewing.

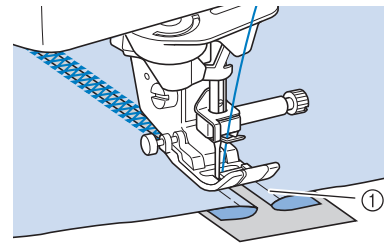

- ① Basting stitches



Memo

- Use a thick thread.



- 4** When sewing is finished, gently tear the paper away.

Tape or Elastic Attaching

- 1** Select a straight stitch and attach presser foot "J".
- 2** Set the stitch length to 4.0 mm (approx. 3/16 inch), and loosen the upper thread tension to 2.0 (see "Setting the Stitch Length" on page 67 and "Setting the Thread Tension" on page 67).



Memo

- Be sure that neither automatic reinforcement  nor automatic thread cutting  is selected.

3 Sew two rows of straight stitches on the right side of the fabric, then pull the bobbin thread to create the necessary gather.

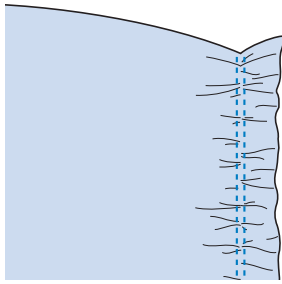

Memo

- Before sewing the straight stitch, rotate the handwheel toward you (counterclockwise) and pull up the bobbin thread. Holding the top and bobbin thread, pull a length of thread out from the rear of the machine. (Be sure that the presser foot is raised.)

4 Place the tape over the gather, and hold it in place with basting pins.

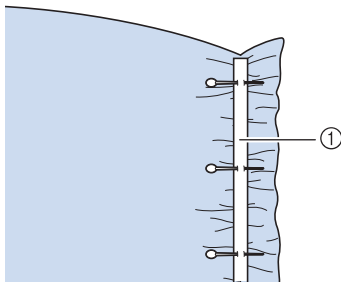

① Tape

5 Select  or .

Memo

- For details on each stitch, refer to the "STITCH SETTING CHART" at the end of this manual.

6 Sew over the tape (or elastic).

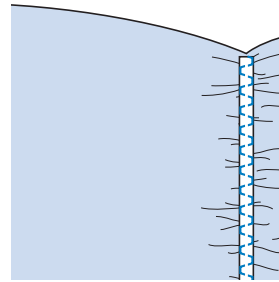
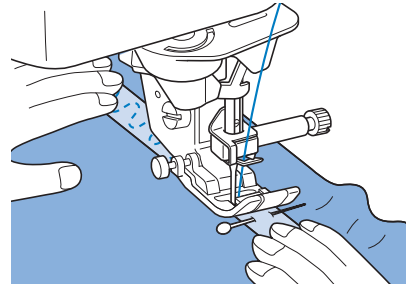

CAUTION

- Be sure the needle does not strike a basting pin, or any other objects, during sewing. The thread could tangle or the needle could break, causing injury.

7 Pull out the straight stitch threads.

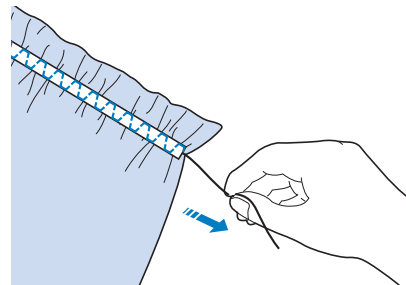

Heirloom

■ Hemstitching (1) (Daisy Stitch)

Use for sewing tablecloths, decorative hems, and decorative stitching on shirt fronts.

Memo

- Use a light to medium weight homespun fabric with a little stiffness.

1 Insert a type 130/705H, size 100/16 Wing needle.

- * This specialty sewing needle is not furnished with your machine. Must be purchased separately.

CAUTION

- The “Automatic Threading” button cannot be used. Thread the wing needle by hand, from front to back. Using the “Automatic Threading” button may result in damage to the machine.
- A more attractive finish can be obtained if you use a “130/705H Wing” needle when sewing these patterns. If using a wing needle and the stitch width has been set manually, check that the needle will not touch the presser foot by carefully rotating the handwheel toward you (counterclockwise) before starting to sew.

2 Select a stitch and attach presser foot “N”.

- * Select any stitch between 3-01 and 3-25.

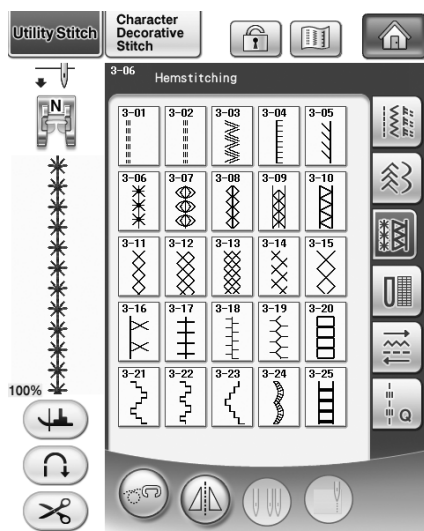

Memo

- For details on each stitch, refer to the “STITCH SETTING CHART” at the end of this manual.

3 Start sewing.

Example: Illustration of finished product

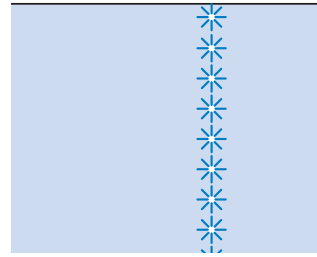

■ Hemstitching (2) (Drawn Work (1))

1 Pull out several threads from one area on a piece of fabric to open the area.

- * Pull out 5 or 6 threads to leave a 3 mm (approx. 1/8 inch) area open.

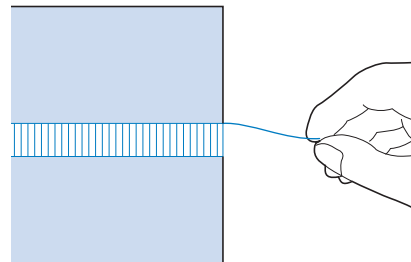

Memo

- Loosely woven fabrics work best for this.

2 Select .

Memo

- For details on each stitch, refer to the “STITCH SETTING CHART” at the end of this manual.

3 Attach presser foot “N”. With the right side of the fabric facing up, sew one edge of the open area.

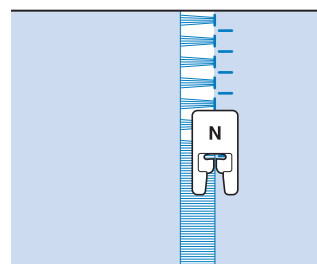

- 4 Press  to create a mirror image of the stitch.
- 5 Match beginning needle drop points on the opposite edge of the open area to keep the stitching symmetrical.

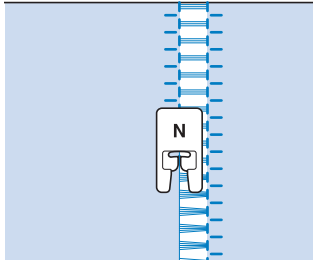

■ Hemstitching (3) (Drawn Work (2))

- 1 Pull out several threads from both sides of the 4 mm (approx. 3/16 inch) area which are not yet open.
 - * Pull out four threads, leave five threads, and then pull out four threads. The width of five threads is approximately 4 mm (approx. 3/16 inch) or less.

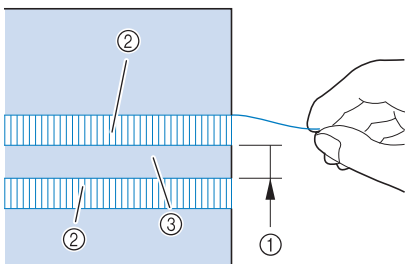

- ① Approx. 4 mm (approx. 3/16 inch) or less
- ② Four threads (pull out)
- ③ Five threads (leave)

- 2 Select .

Memo

- For details on each stitch, refer to the “STITCH SETTING CHART” at the end of this manual.

- 3 Sew the decorative stitch in the center of the five threads created above.

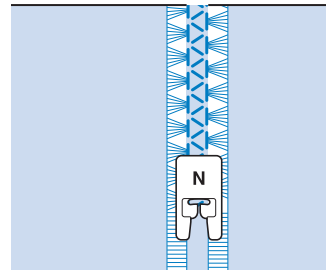































Memo

- A wing needle can be used for Hemstitching (3).

One-step Buttonholes

With one-step buttonholes, you can make buttonholes appropriate to the size of your button.

Stitch	Stitch name	Presser foot	Applications	Stitch width [mm (inch)]		Stitch length [mm (inch)]		Twin needle
				Auto	Manual	Auto	Manual	
	Narrow rounded buttonhole		Buttonhole on light to medium weight fabrics	5.0 (3/16)	3.0 - 5.0 (1/8 - 3/16)	0.4 (1/64)	0.2 - 1.0 (1/64 - 1/16)	NO
	Wide round ended buttonhole		Buttonholes with extra space for larger buttons	5.5 (7/32)	3.5 - 5.5 (1/8 - 7/32)	0.4 (1/64)	0.2 - 1.0 (1/64 - 1/16)	NO
	Tapered round ended buttonhole		Reinforced waist tapered buttonholes	5.0 (3/16)	3.0 - 5.0 (1/8 - 3/16)	0.4 (1/64)	0.2 - 1.0 (1/64 - 1/16)	NO
	Round ended buttonhole		Buttonholes with vertical bar tack in heavyweight fabrics	5.0 (3/16)	3.0 - 5.0 (1/8 - 3/16)	0.4 (1/64)	0.2 - 1.0 (1/64 - 1/16)	NO
	Round ended buttonhole		Buttonholes with bar tack	5.0 (3/16)	3.0 - 5.0 (1/8 - 3/16)	0.4 (1/64)	0.2 - 1.0 (1/64 - 1/16)	NO
	Round double ended buttonhole		Buttonholes for fine, medium to heavyweight fabrics	5.0 (3/16)	3.0 - 5.0 (1/8 - 3/16)	0.4 (1/64)	0.2 - 1.0 (1/64 - 1/16)	NO
	Narrow squared buttonhole		Buttonholes for light to medium weight fabrics	5.0 (3/16)	3.0 - 5.0 (1/8 - 3/16)	0.4 (1/64)	0.2 - 1.0 (1/64 - 1/16)	NO
	Wide squared buttonhole		Buttonholes with extra space for larger decorative buttons	5.5 (7/32)	3.5 - 5.5 (1/8 - 7/32)	0.4 (1/64)	0.2 - 1.0 (1/64 - 1/16)	NO
	Squared buttonhole		Heavy-duty buttonholes with vertical bar tacks	5.0 (7/32)	3.0 - 5.0 (1/8 - 3/16)	0.4 (1/64)	0.2 - 1.0 (1/64 - 1/16)	NO
	Stretch buttonhole		Buttonholes for stretch or woven fabrics	6.0 (15/64)	3.0 - 6.0 (1/8 - 15/64)	1.0 (1/16)	0.5 - 2.0 (1/32 - 1/16)	NO
	Heirloom buttonhole		Buttonholes for heirloom and stretch fabrics	6.0 (15/64)	3.0 - 6.0 (1/8 - 15/64)	1.5 (1/16)	1.0 - 3.0 (1/1 - 1/8)	NO
	Bound buttonhole		The first step in making bound buttonholes	5.0 (3/16)	0.0 - 6.0 (0 - 15/64)	2.0 (1/16)	0.2 - 4.0 (1/64 - 3/16)	NO
	Keyhole buttonhole		Buttonholes in heavyweight or thick fabrics for larger flat buttons	7.0 (1/4)	3.0 - 7.0 (1/8 - 1/4)	0.5 (1/32)	0.3 - 1.0 (1/64 - 1/16)	NO
	Tapered keyhole buttonhole		Buttonholes in medium to heavy weight fabrics for larger flat buttons	7.0 (1/4)	3.0 - 7.0 (1/8 - 1/4)	0.5 (1/32)	0.3 - 1.0 (1/64 - 1/16)	NO
	Keyhole buttonhole		Buttonholes with vertical bar tack for reinforcement in heavyweight or thick fabrics	7.0 (1/4)	3.0 - 7.0 (1/8 - 1/4)	0.5 (1/32)	0.3 - 1.0 (1/64 - 1/16)	NO

One-step buttonholes are sewn from the front of the presser foot to the back, as shown below.

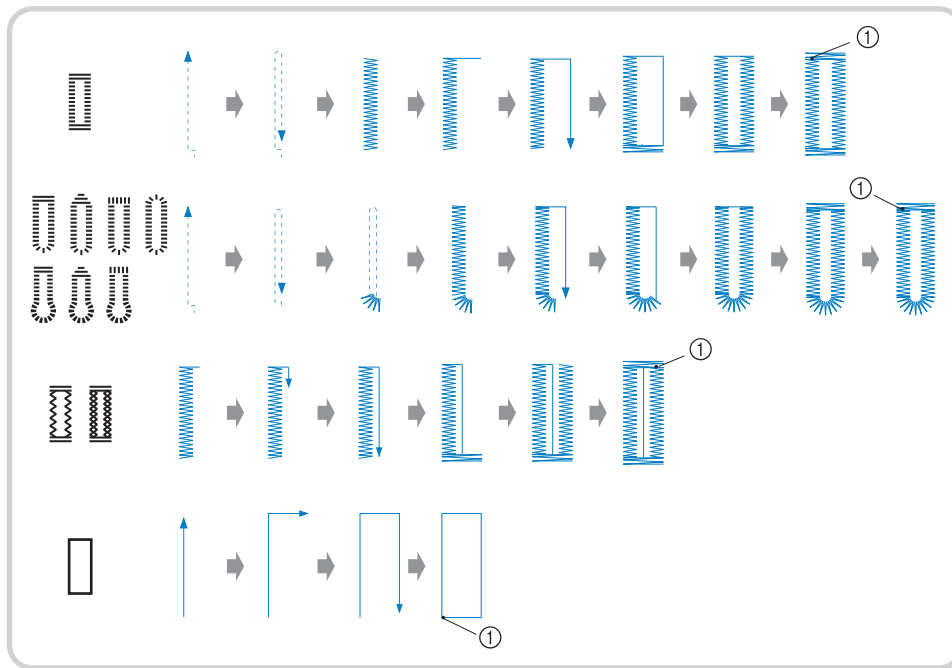

① Reinforcement stitching

1 Select a buttonhole stitch, and attach buttonhole foot “A”.

2 Mark the position and length of the buttonhole on the fabric.

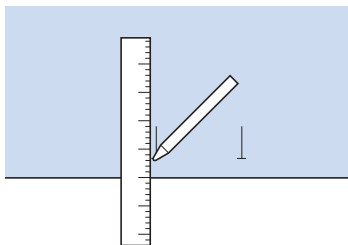

Memo

- The maximum buttonhole length is about 28 mm (approx. 1-1/16 inches) (diameter + thickness of the button).

3 Pull out the button holder plate on the presser foot, and insert the button that will be put through the buttonhole. Then tighten the button holder plate around the button.

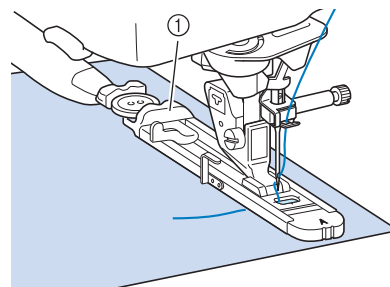

① Button holder plate

Memo

- The size of the buttonhole is determined by the size of the button in the button holder plate.

4 Align the presser foot with the mark on the fabric, and lower the presser foot.

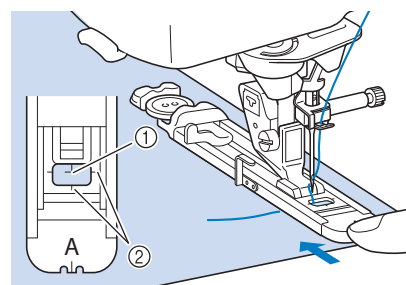

① Mark on the fabric
② Marks on the presser foot

**Note**

- Pass the thread underneath the presser foot.
- Slide the outside frame of the buttonhole foot backward as far as possible as shown in the illustration, making sure that there is no gap behind the part of the foot marked "A". If the buttonhole foot is not slid back as far as possible, the buttonhole will not be sewn at the correct size.

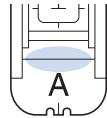

- 5** Lower the buttonhole lever so that it is positioned behind the metal bracket on the buttonhole foot.

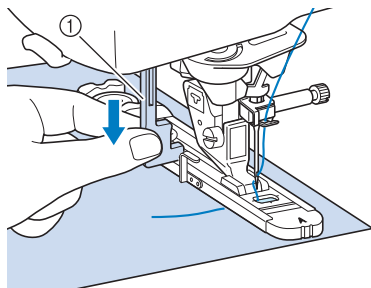

① Buttonhole lever

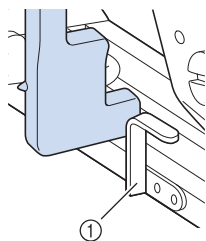

① Metal bracket

- 6** Gently hold the end of the upper thread, and then start sewing.

- * Feed the fabric carefully by hand while the buttonhole is sewn.

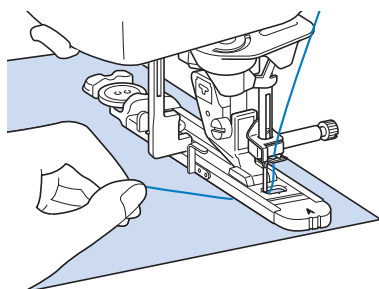

→ Once sewing is completed, the machine automatically sews reinforcement stitches, and then stops.

**Memo**

- If automatic thread cutting is turned on before you start sewing, both threads are automatically cut after the reinforcement stitches are sewn. If the fabric does not feed (for example, because it is too thick), increase the stitch length setting.

- 7** Insert a pin along the inside of one of the bar tacks, and then insert the seam ripper into the center of the buttonhole and cut towards the pin.

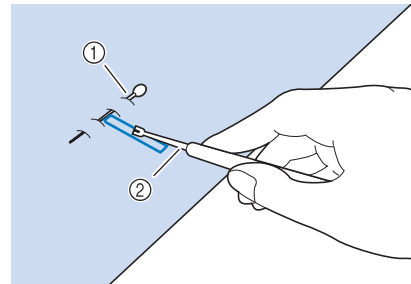

- ① Basting pin
② Seam ripper

⚠ CAUTION

- When using the seam ripper to open the buttonhole, do not put your hand or finger in the path of the ripper. The ripper may slip and cause injury. Do not use the seam ripper in any other way than how it is intended.

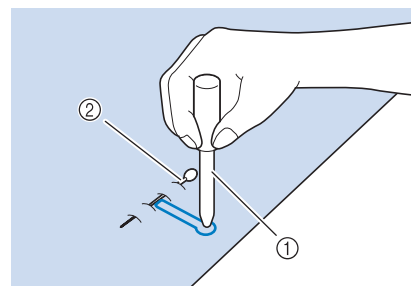

**Memo**

- For keyhole buttonholes, use the eyelet punch to make a hole in the rounded end of the buttonhole. Then insert a pin along the inside of one of the bar tacks, insert a seam ripper into the hole made with the eyelet punch, and cut towards the pin.



- ① Eyelet punch
② Basting pin

■ Sewing Stretch Fabrics

When sewing on stretch fabric with  or , sew the buttonhole stitches over a gimp thread.

- 1** Hook the gimp thread onto the back of presser foot "A". Insert the ends into the grooves at the front of the presser foot, and then temporarily tie them there.

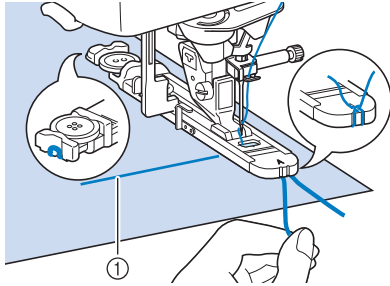

① Upper thread

- 2** Lower the presser foot and start sewing.

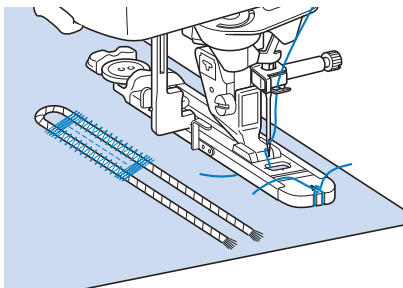

Memo

- Set the width of the satin stitches to the width of the gimp thread, and set the buttonhole width to be 2-3 times the width of the gimp thread.

- 3** Once sewing is completed, gently pull the gimp thread to remove any slack, and trim off any excess.

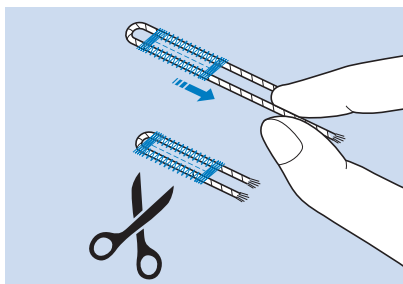

Memo

- After using the seam ripper to cut open the threads over the buttonhole, trim off the threads.

■ Odd Shaped Buttons/Buttons that do Not Fit into the Button Holder Plate

Use the markings on the presser foot scale to set the size of the buttonhole. One mark on the presser foot scale equals 5 mm (approx. 3/16 inch). Add the button diameter and thickness together, and then set the plate at the calculated value.

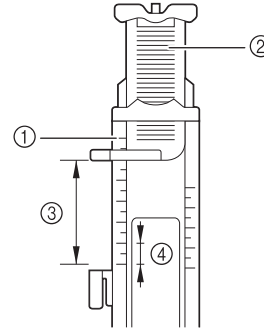

- ① Presser foot scale
- ② Button holder plate
- ③ Completed measurement of diameter + thickness
- ④ 5 mm (approx. 3/16 inch)

Memo

- For example, for a button with a diameter of 15 mm (approx. 9/16 inch) and a thickness of 10 mm (approx. 3/8 inch), the scale should be set at 25 mm (approx. 1 inch).

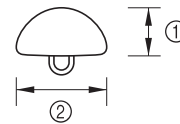

- ① 10 mm (approx. 3/8 inch)
- ② 15 mm (approx. 9/16 inch)









Four-step Buttonholes

You can sew 4-step buttonholes using the following 4 stitches together. You can sew any desired length for the buttonhole when using 4-step buttonholes. 4-step buttonholes are a good option when attaching oversize buttons.



Note

- When changing the stitch settings, make sure that all stitch settings are changed to match.

Stitch	Stitch name	Presser foot	Applications	Stitch width [mm (inch)]		Stitch length [mm (inch)]		Twin needle
				Auto	Manual	Auto	Manual	
	4 steps buttonhole 1		Left side of 4 steps buttonhole	5.0 (7/32)	1.5 - 7.0 (1/16 - 1/4)	0.4 (1/64)	0.2 - 1.0 (1/64 - 1/16)	NO
	4 steps buttonhole 2		Bar tack of 4 steps buttonhole	5.0 (7/32)	1.5 - 7.0 (1/16 - 1/4)	0.4 (1/64)	0.2 - 1.0 (1/64 - 1/16)	NO
	4 steps buttonhole 3		Right side of 4 steps buttonhole	5.0 (7/32)	1.5 - 7.0 (1/16 - 1/4)	0.4 (1/64)	0.2 - 1.0 (1/64 - 1/16)	NO
	4 steps buttonhole 4		Bar tack of 4 steps buttonhole	5.0 (7/32)	1.5 - 7.0 (1/16 - 1/4)	0.4 (1/64)	0.2 - 1.0 (1/64 - 1/16)	NO

Four-step buttonholes are sewn as shown below.

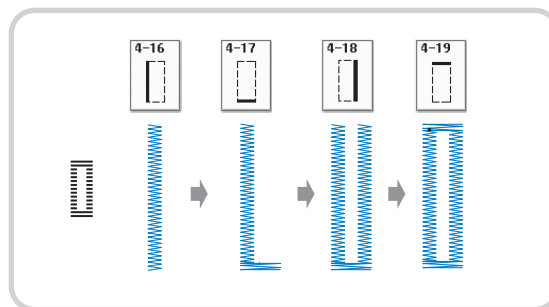

- 1 Mark the position and length of the buttonhole on the fabric.

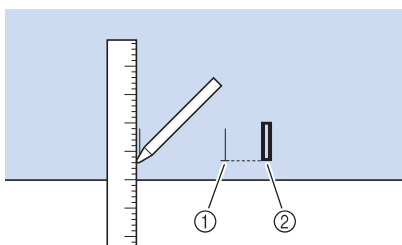

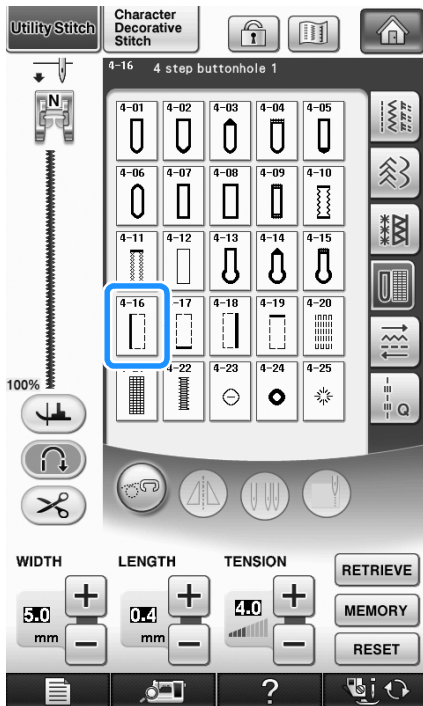

- ① Marks on fabric
- ② Finished stitching

- 2** Attach monogramming foot “N”, and select stitch  to sew the left side of the buttonhole.

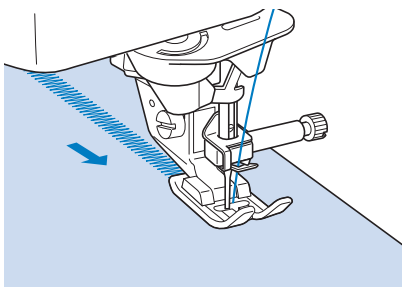

- 3** Press the “Start/Stop” button to start sewing.
- 4** Sew the desired length for the buttonhole and press the “Start/Stop” button again.



- 5** Select stitch  to sew the bar tack and press the “Start/Stop” button.

→ The machine will automatically stop after sewing the bar tack.

- 6** Select stitch  to sew the right side of the buttonhole, and press the “Start/Stop” button to begin sewing.

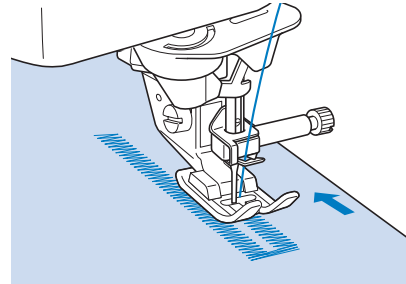

- 7** Sew the right side of the buttonhole and press the “Start/Stop” button again.

* Sew the right side of the buttonhole the same length as the left.

- 8** Select stitch  to sew the bar tack and then press the “Start/Stop” button.



→ The machine will automatically sew off the bar tack tie and stop when the bar tack is complete.

- 9** Raise the presser foot and remove the fabric.

- 10** Refer to page 123 to open the buttonhole.

■ Darning

Use darning stitches for mending and other applications.

Stitch	Stitch name	Presser foot	Applications	Stitch width [mm (inch)]		Stitch length [mm (inch)]		Twin needle
				Auto	Manual	Auto	Manual	
4-20	Darning		Darning medium weight fabric	7.0 (1/4)	2.5 - 7.0 (3/32 - 1/4)	2.0 (1/16)	0.4 - 2.5 (1/64 - 1/16)	NO
4-21	Darning		Darning heavyweight fabric	7.0 (1/4)	2.5 - 7.0 (3/32 - 1/4)	2.0 (1/16)	0.4 - 2.5 (1/64 - 1/16)	NO

Darning is performed by sewing from the front of the presser foot to the back as shown below.

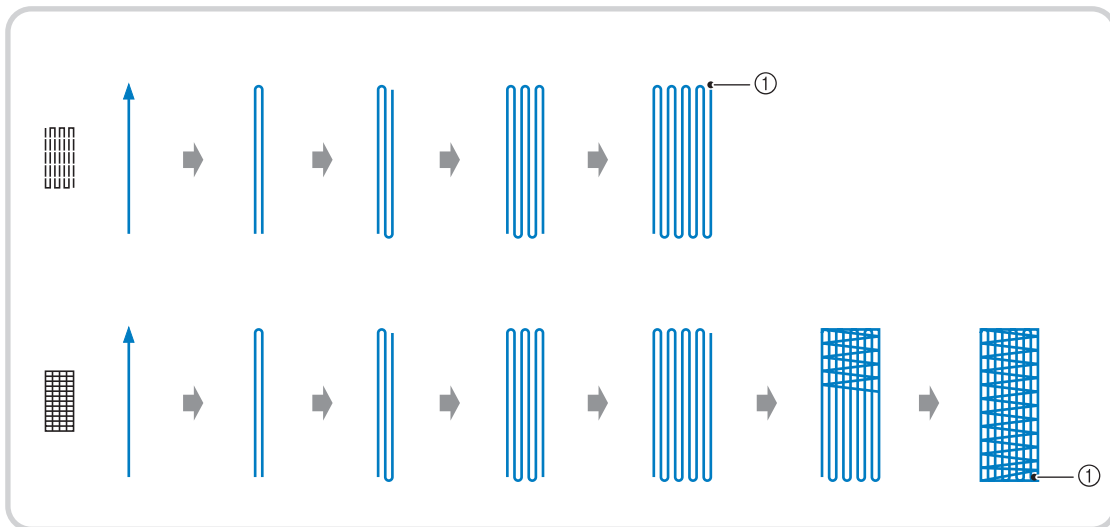

① Reinforcement stitches

- 1 Select a stitch, and attach buttonhole foot "A".
- 2 Set the scale to the desired length of the darning.

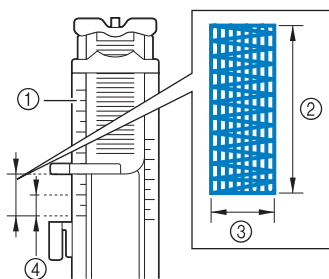

- ① Presser foot scale
- ② Completed length measurement
- ③ Width 7 mm (approx. 1/4 inch)
- ④ 5 mm (approx. 3/16 inch)

Memo

- The maximum length for darning is 28 mm (approx. 1-1/16 inches).

- 3** Check that the needle drops at the desired position and lower the presser foot, making sure the upper thread passes underneath the buttonhole foot.

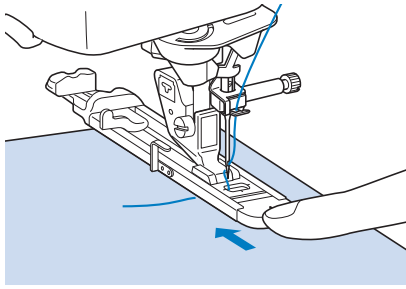

Note

- Pass the thread underneath the presser foot.
- Set the presser foot so that there is no gap behind the section marked with an “A” (the shaded area in the illustration below). If there is a gap, the size of the darning will not be correct.

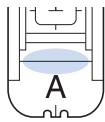

- 4** Lower the buttonhole lever so that it is positioned behind the metal bracket on the buttonhole foot.

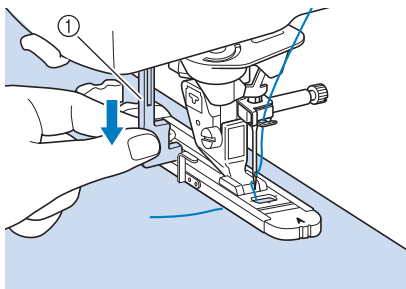

① Buttonhole lever

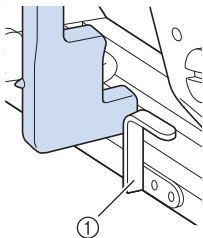

① Metal bracket

- 5** Gently hold the end of the upper thread, and then press the “Start/Stop” button to start the machine.

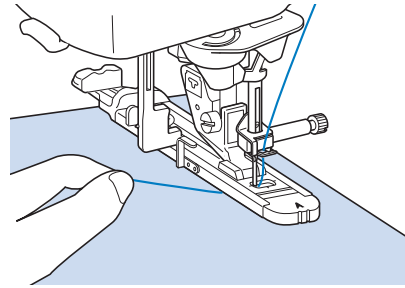

→ Once sewing is completed, the machine automatically sews reinforcement stitches, and then stops.



Memo

- If automatic thread cutting is turned on before you start sewing, both threads are automatically cut after the reinforcement stitches are sewn. If the fabric does not feed (for example, because it is too thick), increase the stitch length setting.

Bar Tacks

Use bar tacks to reinforce areas that will be subject to strain, such as pocket corners.

Stitch	Stitch name	Presser foot	Applications	Stitch width [mm (inch)]		Stitch length [mm (inch)]		Twin needle
				Auto	Manual	Auto	Manual	
4-22	Bar tack		Reinforcement at opening of pocket, etc.	2.0 (1/16)	1.0 - 3.0 (1/16 - 1/8)	0.4 (1/64)	0.3 - 1.0 (1/64 - 1/16)	NO

1 Select .

2 Attach buttonhole foot "A" and set the scale to the length of the bar tack you wish to sew.

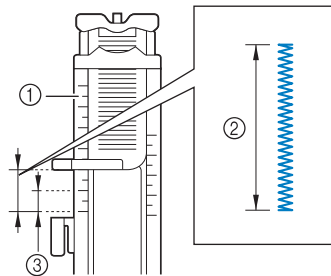

- ① Presser foot scale
- ② Completed length measurement
- ③ 5 mm (approx. 3/16 inch)

Memo

- Bar tacks can be between 5 mm (approx. 3/16 inch) and 28 mm (approx. 1-1/16 inches). Bar tacks are usually between 5 mm (approx. 3/16 inch) and 10 mm (approx. 3/8 inch).

3 Set the fabric so that the pocket moves toward you during sewing.

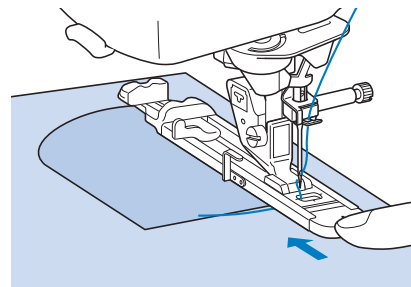

Note

- Pass the thread underneath the presser foot.
- Slide the outside frame of the buttonhole foot backward as far as possible as shown in the illustration, making sure that there is no gap behind the part of the foot marked "A". If the buttonhole foot is not slid back as far as possible, the bar tack will not be sewn to the correct size.

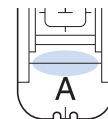

4 Check the first needle drop point and lower the presser foot.

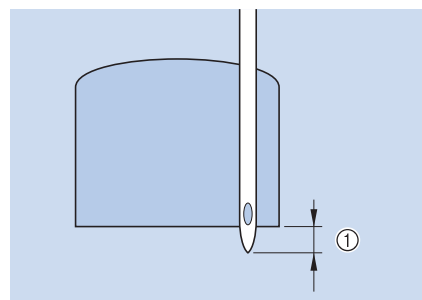

- ① 2 mm (approx. 1/16 inch)

3

- 5** Lower the buttonhole lever so that it is positioned behind the metal bracket on the buttonhole foot.

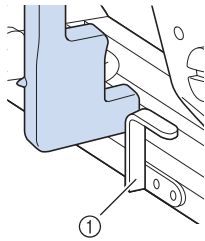
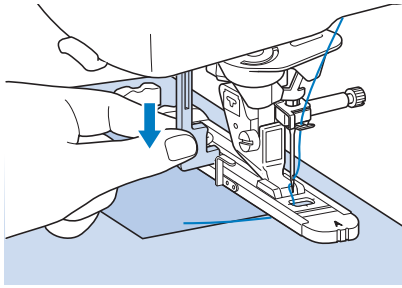

① Metal bracket

- 6** Gently hold the end of the upper thread and begin sewing.

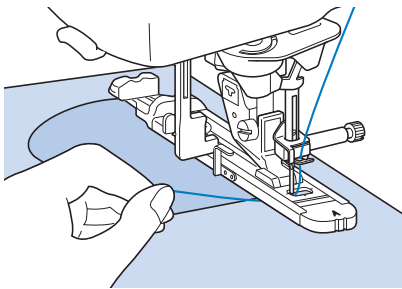

→ When sewing is completed, the machine will sew reinforcement stitches and stop automatically.

■ Bar Tacks on Thick Fabrics

Place a piece of folded fabric or cardboard beside the fabric being sewn to level the buttonhole foot and allow for easier and even feeding.

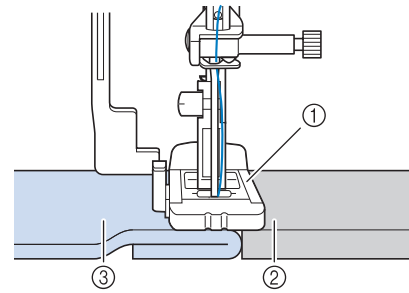



- ① Presser foot
- ② Thick paper
- ③ Fabric

Memo

- If automatic thread cutting is turned on before you start sewing, both threads are automatically cut after the reinforcement stitches are sewn. If the fabric does not feed (for example, because it is too thick), increase the stitch length setting.

Button Sewing

Buttons with 2 or 4 holes can be attached, using the machine.

Stitch	Stitch name	Presser foot	Applications	Stitch width [mm (inch)]		Stitch length [mm (inch)]		Twin needle
				Auto	Manual	Auto	Manual	
4-23 	Button sewing		Attaching buttons	3.5 (1/8)	2.5 - 4.5 (3/32 - 3/16)	—	—	NO



Note

- Do not use the automatic thread cutting function when sewing buttons. Otherwise, you will lose the thread ends.

3

Utility Stitches

1 Select .

→ The feed dogs are lowered automatically.

2 Raise the presser foot.

3 Attach button sewing foot “M”, slide the button along the metal plate and into the presser foot, and lower the presser foot.

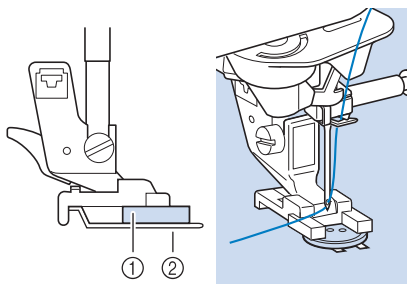

- ① Button
② Metal plate

4 Rotate the handwheel toward you (counterclockwise) to check that the needle goes into each hole correctly.

- * If the needle does not reach the holes on the left side, adjust the stitch width.
- * To attach the button more securely, repeat the process.

5 Gently hold the end of the upper thread and start sewing.

→ The machine stops automatically when sewing is finished.

! CAUTION

- Make sure the needle does not strike the button during sewing. The needle may break and cause injury.

6 From the wrong side of the fabric, pull the end of the bobbin thread to pull the upper thread through to the wrong side of the fabric. Tie the two thread ends together and cut the threads.

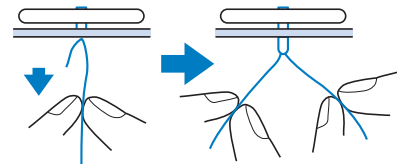

7 After the button is attached, select another stitch and rotate the handwheel toward you (counterclockwise) to raise the feed dogs.

■ Attaching 4 Hole Buttons

Sew the two holes closest to you. Then raise the presser foot and move the fabric so that the needle goes into the next two holes, and sew them in the same way.

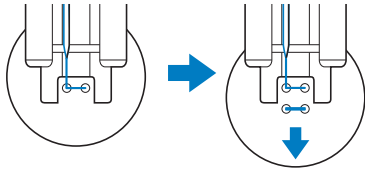

■ Attaching a Shank to the Button

- 1 Pull the shank lever toward you before sewing.

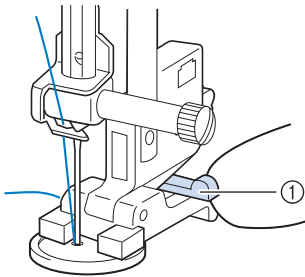

① Shank lever

- 2 Pull the two ends of the upper thread between the button and the fabric, wind them around the shank, and then tie them firmly together.

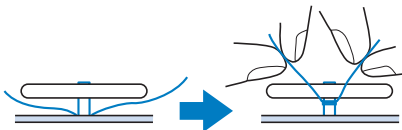

- 3 Tie the ends of the bobbin thread from the beginning and end of sewing together on the wrong side of the fabric.

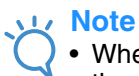





Note



- When sewing is completed, be sure to select the other stitch and rotate the handwheel toward you (counterclockwise) to raise the feed dogs.



- 4 Cut off any excess thread.

Eyelet

Use this stitch for making belt holes and other similar applications.

Stitch	Stitch name	Presser foot	Applications	Stitch width [mm (inch)]		Stitch length [mm (inch)]		Twin needle
				Auto	Manual	Auto	Manual	
4-24 	Eyelet		For making eyelets, holes on belts, etc.	7.0 (1/4)	7.0 6.0 5.0 (1/4 15/64 3/16)	7.0 (1/4)	7.0 6.0 5.0 (1/4 15/64 3/16)	NO
4-25 	Star eyelet		For making star-shaped eyelets on holes.	—	—	—	—	NO

1 Select  or .

2 Use   in either the stitch width display or the stitch length display to choose the size of the eyelet.

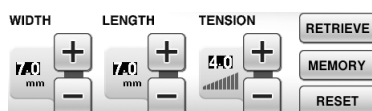

* Actual size

- ① Large 7 mm (approx. 1/4 inch)
- ② Medium 6 mm (approx. 15/64 inch)
- ③ Small 5 mm (approx. 3/16 inch)



Note

- Only one size is available for .

3 Attach monogramming foot “N”, then rotate the handwheel toward you (counterclockwise) to check the needle drop position.

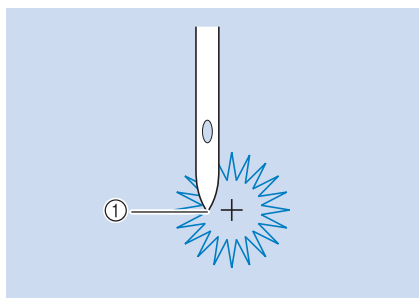

① Needle drop position

4 Lower the presser foot and start sewing.

→ When sewing is finished, the machine sews reinforcement stitches and stops automatically.



Note

- If the stitch pattern comes out poorly, make adjustments to “SEWING STITCH PATTERNS” on page 152.

5 Use the eyelet punch to make a hole in the center of the stitching.

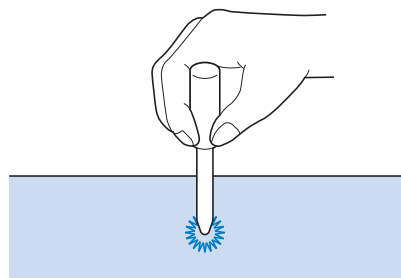

3

Utility Stitches

Multi-directional Sewing (Straight Stitch and Zigzag Stitch)

Use these stitch patterns to attach patches or emblems to pant legs, shirt sleeves, etc.

- 1 Remove the flat bed attachment to use the free-arm.

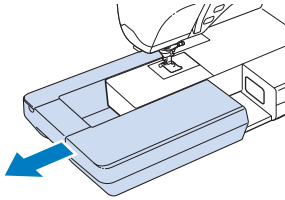

Memo

- Insert the tubular piece of fabric onto the free-arm, and then sew in the order shown in the illustration.

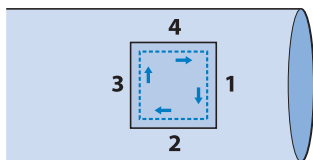

- 2 Select  and attach monogramming foot “N”.

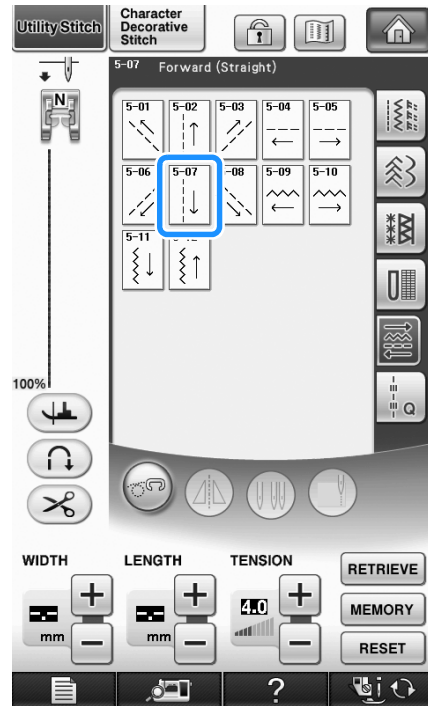

Memo

- For details on each stitch, refer to the “STITCH SETTING CHART” at the end of this manual.

- 3 Set the needle in the fabric at the sewing start point, and sew seam “1” as shown.

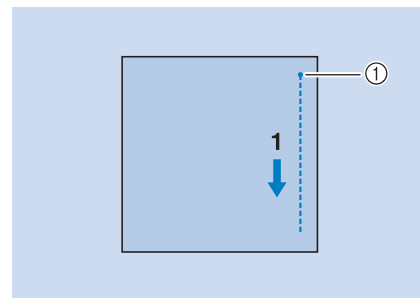

① Start Point

4 Select  and sew seam "2" as shown.

* The fabric will move sideways, guide the fabric by hand to keep sewing straight.

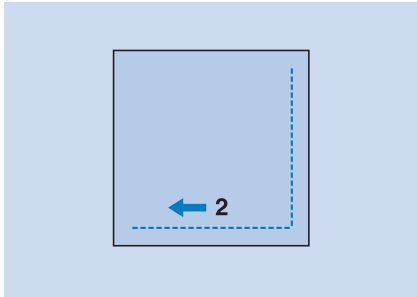

5 Select  and sew seam "3" as shown.

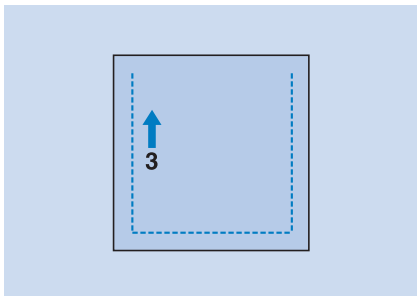

→ The fabric feeds forward while stitching backward.

6 Select  and sew seam "4" as shown.

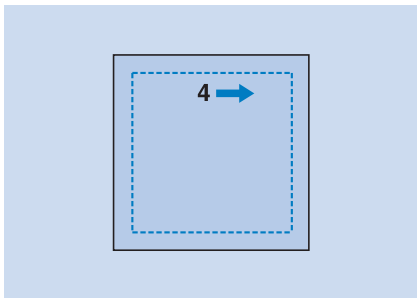

→ The seam will be connected to the starting point of seam 1.

Zipper Insertion

■ Centered Zipper

Use for bags and other such applications.

1 Select  .

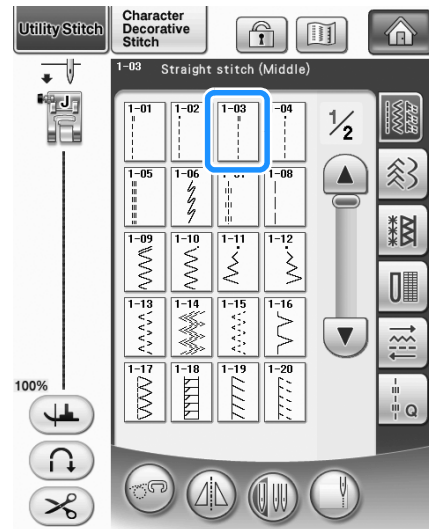

Memo

- For details on each stitch, refer to the "STITCH SETTING CHART" at the end of this manual.

Note

- Make sure you sew using the middle needle position.

2 Attach presser foot "J" and sew straight stitches up to the zipper opening. Change to a basting stitch (see page 87) and sew to the top of the fabric.

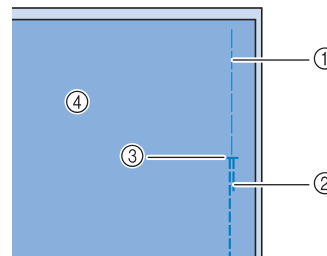

- ① Basting stitches
- ② Reverse stitches
- ③ End of zipper opening
- ④ Wrong side

- 3** Press the seam allowance open and attach the zipper with a basting stitch in the middle of each side of the zipper tape.

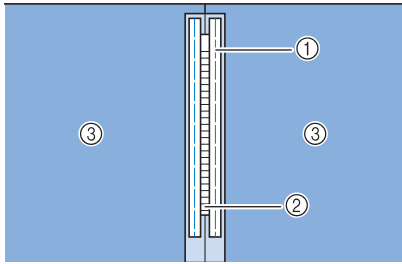

- ① Basting stitches
- ② Zipper
- ③ Wrong side

- 4** Remove presser foot “J”. Align the right side of the pin in zipper foot “I” with the presser foot holder, and attach the zipper foot.

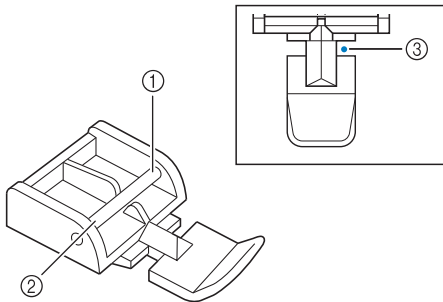

- ① Right
- ② Left
- ③ Needle drop position

CAUTION

- When using zipper foot “I”, make sure the straight stitch, middle needle position is selected. Rotate the handwheel toward you (counterclockwise) to make sure the needle does not strike the presser foot. If another stitch is selected, the needle will strike the presser foot, causing the needle to break and possibly causing injury.

- 5** Topstitch 7 to 10 mm (approx. 1/4 to 3/8 inch) from the seamed edge of the fabric, then remove the basting.

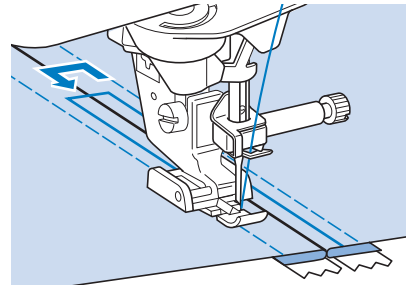

CAUTION

- Make sure the needle does not strike the zipper during sewing. If the needle strikes the zipper, the needle may break, leading to injury.

Inserting a Side Zipper

Use for side zippers in skirts or dresses.

- 1** Select 1-03.

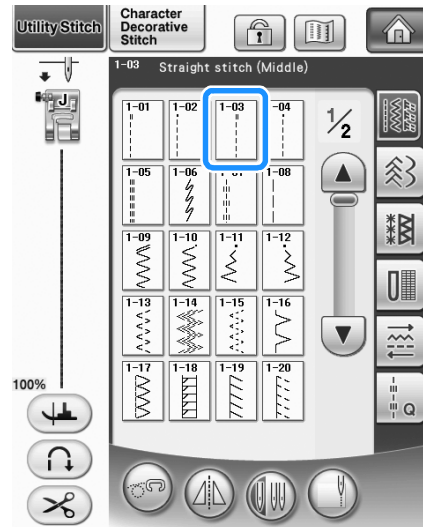

Note

- Make sure you sew using the middle needle position.

- 2** Attach presser foot “J” and sew straight stitches up to the zipper opening. Change to a basting stitch and sew to the top of the fabric.

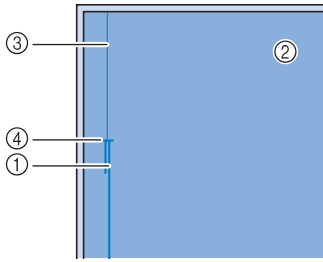

- ① Reverse stitches
② Wrong side of fabric
③ Basting stitches
④ End of zipper opening

- 3** Press the seam allowance open and align the folded hem along the teeth of the zipper, while maintaining 3 mm (approx. 1/8 inch) of sewing space.

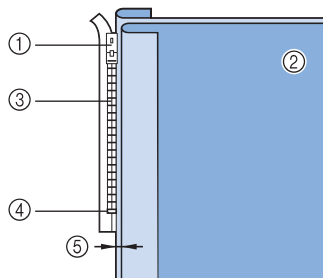

- ① Zipper pull tab
② Wrong side of fabric
③ Zipper teeth
④ End of zipper opening
⑤ 3 mm (approx. 1/8 inch)

- 4** Remove presser foot “J”.

- 5** Align the right side of the pin in zipper foot “I” with the presser foot holder, and attach the presser foot.

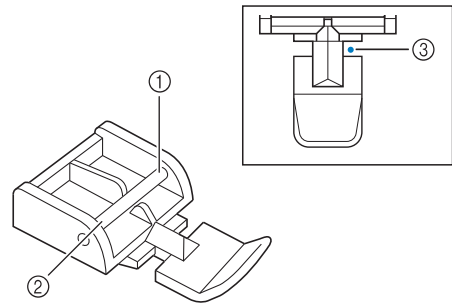

- ① Right
② Left
③ Needle drop position

CAUTION

- When using zipper foot “I”, make sure the straight stitch, middle needle position is selected. Rotate the handwheel toward you (counterclockwise) to make sure the needle does not strike the presser foot. If another stitch is selected, the needle will strike the presser foot, causing the needle to break and possibly causing injury.

- 6** Set the presser foot in the 3 mm (approx. 1/8 inch) margin.

- 7** Starting from the end of the zipper opening, sew to a point about 50 mm (approx. 2 inches) from the edge of the fabric, then stop the machine.

- 8** Pull down the zipper slider, then continue sewing to the edge of the fabric.

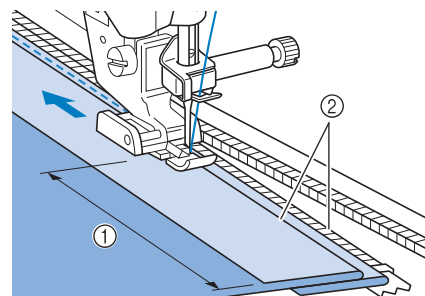

- ① 50 mm (approx. 2 inches)
② 3 mm (approx. 1/8 inch)

CAUTION

- Make sure the needle does not strike the zipper during sewing. If the needle strikes the zipper, the needle may break, leading to injury.

- 9** Close the zipper, turn the fabric over, and sew a basting stitch.

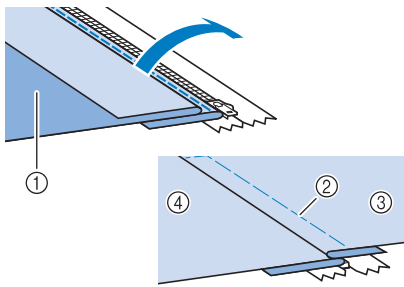

- ① Front of the skirt (wrong side of fabric)
- ② Basting stitches
- ③ Front of the skirt (right side of fabric)
- ④ Back of the skirt (right side of fabric)

- 10** Remove the presser foot, and reattach it so that the left side of the pin is attached to the presser foot holder.

* When sewing the left side of the zipper, the needle should drop on the right side of the presser foot. When sewing the right side of the zipper, the needle should drop on the left side of the presser foot.

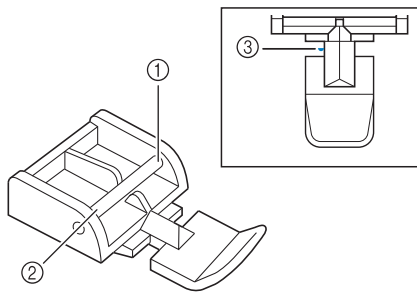

- ① Right
- ② Left
- ③ Needle drop position

- 11** Set the fabric so that the left edge of the presser foot touches the edge of the zipper teeth.

- 12** Sew reverse stitches at the top of the zipper, then continue sewing.

- 13** Stop sewing about 50 mm (approx. 2 inches) from the edge of the fabric, leave the needle in the fabric, and remove the basting stitches.

- 14** Open the zipper and sew the rest of the seam.

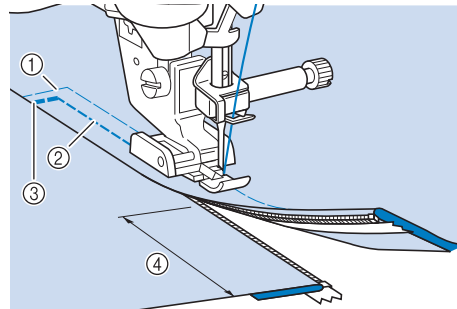

- ① Basting stitches
- ② 7 to 10 mm (approx. 1/4 inch to 3/8 inch)
- ③ Reverse stitches
- ④ 50 mm (approx. 2 inches)

Edge Sewing

Using the built-in camera, the width of the area from the edge of the fabric to the stitching line can be measured and set for edge sewing. This function can be used when the edge of the fabric is straight or a gentle curve.

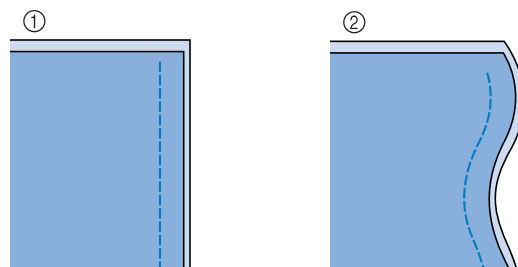

- ① Straight
- ② Curved

**Note**

- Clean stitching cannot be sewn if this function is used when the edge of the fabric has corners as shown below.

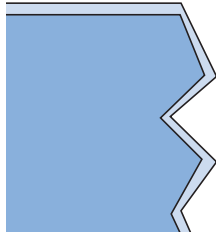

- When edge sewing using the built-in camera, make sure that the room is evenly lit. If the brightness in the room changes while edge sewing, the built-in camera may not be able to detect the edge of the fabric.
- The built-in camera detects the contrast between the fabric and the background. Therefore, observe the following precautions.
 - If the edge of the fabric is fraying, cut off any excess fabric threads.
 - If the fabric has a complicated pattern, is sheer or is glossy, such as a vinyl material, the built-in camera may not be able to detect it correctly.
- For best results, iron the fold when folding the edge of the fabric for edge sewing.
- When “Width Control” on page 1/7 of the settings screen is set to “ON” or when “Needle Position – Stitch Placement” on page 3/7 is set to “ON”, the built-in camera cannot be used with edge sewing. If either of these parameters are set to “ON”,  appears gray and cannot be selected. Before using the built-in camera for edge sewing, set “Width Control” and “Needle Position – Stitch Placement” in the settings screen to “OFF”.

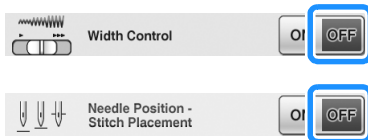
**1 Select a stitch.**

- * Edge sewing using the built-in camera cannot be used with patterns where  appears in gray when the pattern is selected.

2 Attach the vertical stitch alignment foot “V”.**! CAUTION**

- When edge sewing with the built-in camera, be sure to use the vertical stitch alignment foot “V”. In order to maintain a fixed distance from the edge of the fabric, the needle will slightly move to either side, even when sewing with a straight stitch. If a different presser foot is used, it may be hit by the needle, causing the needle to break or resulting in injuries.

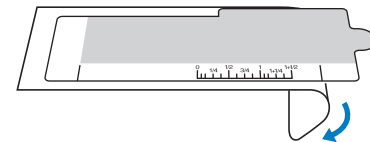
3 Peel off the transparent sheet of the edge sewing sheet.

4 Place the edge sewing sheet on top of the needle plate cover.

Align the guides on the edge sewing sheet with the sides of the needle plate cover, and then adjust the position of the edge sewing sheet so that its cutout aligns with the edges of the opening for the feed dogs. Position the edge sewing sheet so that there is no gap between it and the edges of the opening for the feed dogs.

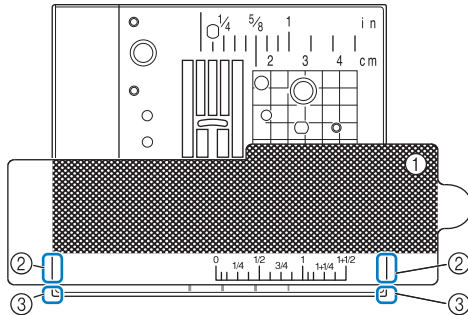

- ① Edge sewing sheet
- ② Guides on edge sewing sheet
- ③ Sides of needle plate cover

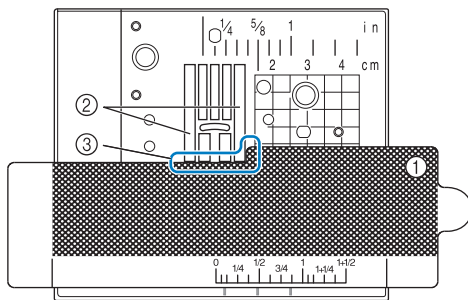

- ① Edge sewing sheet
- ② Feed dogs
- ③ Between the feed dogs and the edge sewing sheet

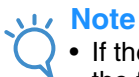

Note

- If the metal needle plate is visible between the feed dogs and the edge sewing sheet, the fabric may be incorrectly detected by the built-in camera.



Memo

- Before using the edge sewing sheet, peel off the transparent sheet. After use, affix the edge sewing sheet to the transparent sheet to prevent it from collecting dust.

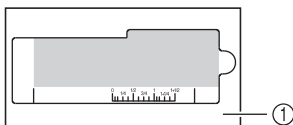

- ① Transparent sheet
- Set a fully wound bobbin before starting to use the edge sewing feature and built-in camera. If you need to change the bobbin while edge sewing, remove the edge sewing sheet carefully and place it again after changing the bobbin.

5 Press

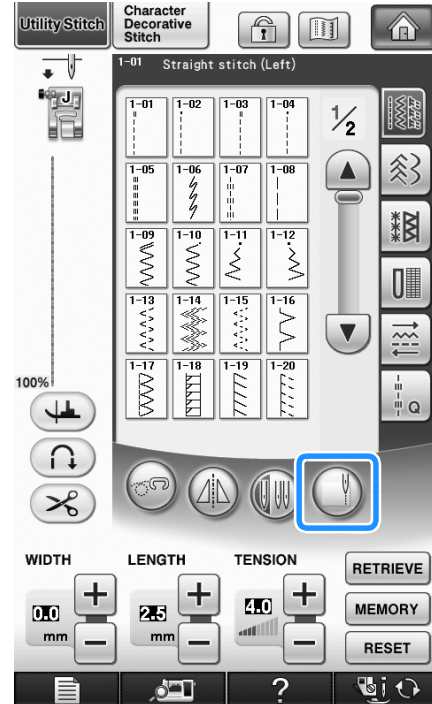

→ Depending on the stitch, the straight stitch with the middle (center) needle position is selected, regardless of the preset stitch width.

* Regardless of the setting selected in the machine settings screen, the brightness of the light changes to "5".



Note

- After is pressed, the stitch width and stitch length cannot be changed. Change the stitch width and stitch length before pressing .

6 When the message shown below appears, check that the vertical stitch alignment foot "V" is attached and that the edge sewing sheet is positioned, and then press

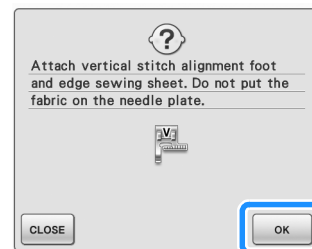

→ Then the edge sewing window appears.

Note

- Before pressing **OK**, install the vertical stitch alignment foot “V” and position the edge sewing sheet; otherwise, the built-in camera cannot detect the fabric.
- If **OK** is pressed before the edge sewing sheet is positioned, the message shown in step 6 appears again.
- After pressing **OK**, do not place your hands or any other object near the needle plate until the message “Recognizing...” disappears.

7 Place the fabric under the presser foot.

8 Move the fabric to the desired position for edge sewing. Position the fabric so that its edge is as straight as possible.

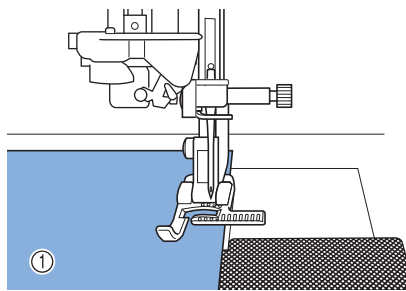

① Fabric

Note

- When pinning the fabric, insert the pins as shown below. If the head of the pin extends off the edge of the fabric, the fabric may not be correctly detected.

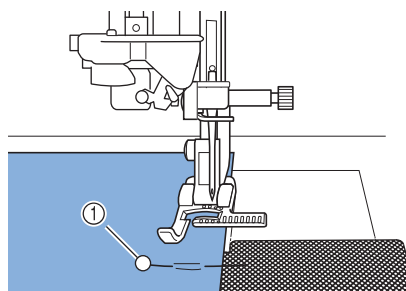

① Basting pin

9 Check that the built-in camera is correctly detecting the fabric.

- * Press to change the colors of the fabric edge indicator line and starting point according to the color of the fabric. Each press of this key changes the color of the fabric edge indicator line to red (with a blue starting point), blue (with a black starting point) or black (with a red starting point).

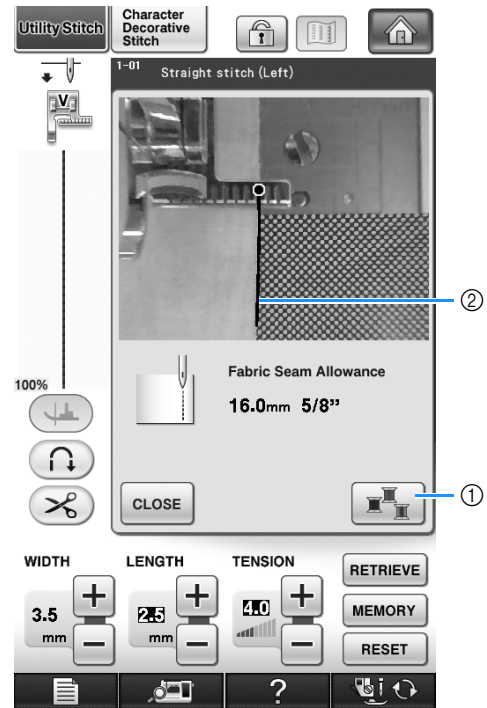

- ① Key for changing the color of the fabric edge indicator line
- ② Fabric edge indicator line

When the Built-In Camera Can Detect the Edge of the Fabric

The fabric edge indicator line appears correctly following the edge of the fabric.

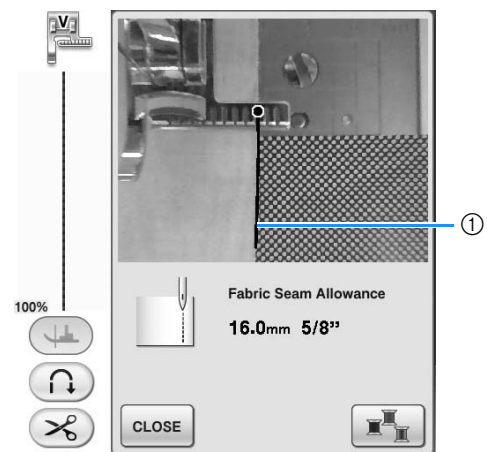

- ① Fabric edge indicator line

When the Fabric Edge Indicator Line Does Not Appear

The built-in camera cannot detect the edge of the fabric.

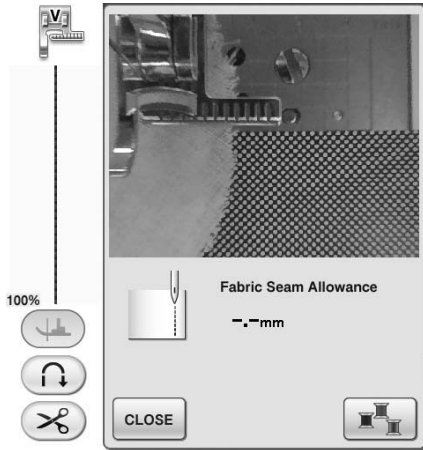

Press **CLOSE**, and then perform the procedure again starting with step 1.

When the Fabric Edge Indicator Line Is Not Aligned With the Edge of the Fabric

The fabric edge indicator line that appears is not aligned with the edge of the fabric. The fabric at the beginning of sewing is not straight.

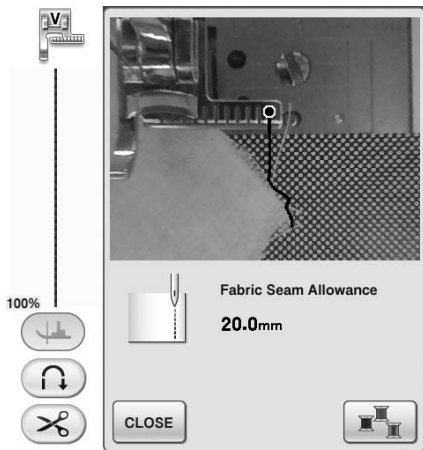

Try to straighten the edge of the fabric at the beginning of sewing (so it is parallel with the edge of the presser foot).

Note

- If a straight part of fabric edge indicator line (shown below) does not follow the edge of the fabric, edge sewing cannot be sewn correctly.

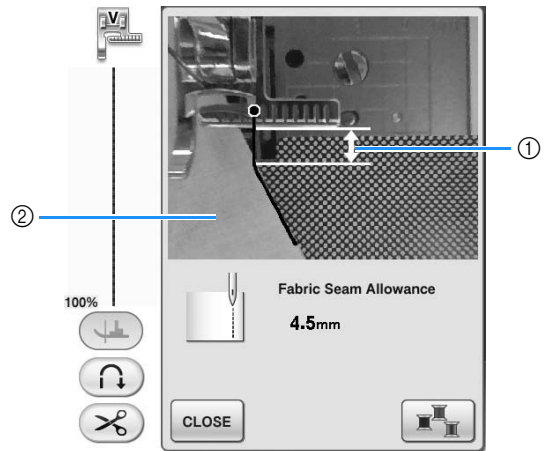

- ① Straight part
- ② Fabric

10 While checking the screen for the distance from the fabric edge to the edge sewing position, move the fabric to the desired position.

- * The starting point of the fabric edge indicator line shows the position for the start of sewing. The actual position for the start of sewing is directly below the needle and parallel to the starting point.

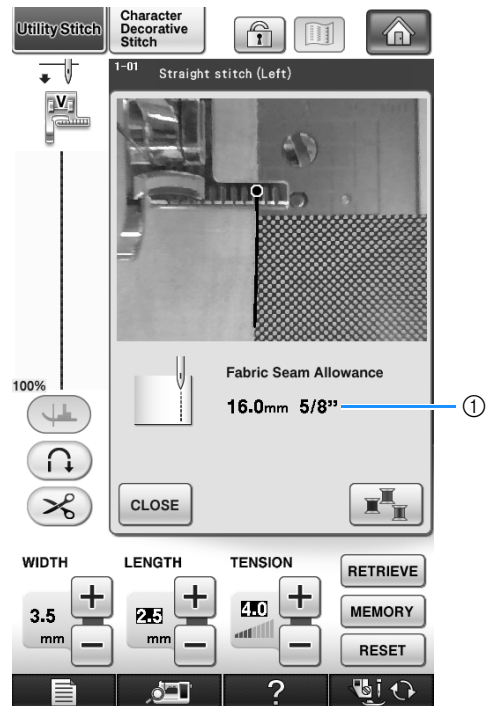

- ① Distance from edge of fabric

Example: When a straight stitch is selected

(example: )

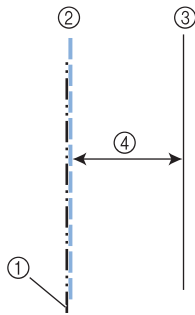

- ① Middle needle position
- ② Stitching
- ③ Edge of fabric
- ④ Width of edge sewing



Note

- Distances between 1.5 mm (about 1/16 inch) and 38.5 mm (about 1-1/2 inches) can be measured. The distance is displayed in the screen in 0.5 mm (about 1/64 inch) increments.
- The distance is displayed in millimeters. However, depending on the measurement setting, it can also be displayed in inches.
- If “_ _ mm” appears as the distance and no inch measurement is displayed, the built-in camera is not able to detect the edge of the fabric.
- When a straight stitch is selected, use the scale on the edge sewing sheet as a guide for positioning the fabric for edge sewing.

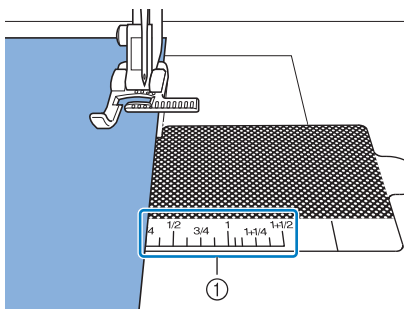

- ① Scale on the edge sewing sheet

11 Lower the presser foot.

→ The distance from the edge of the fabric to the seam is set.



Memo

- If the knee lifter is used to lower the presser foot, the fabric can be held in place with both hands so the fabric does not move when the presser foot is lowered.

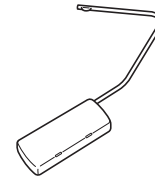

12 Press the “Start/Stop” button to start edge sewing.

- Sewing starts with the set distance to the edge of the fabric maintained.
- * While sewing, use the red scale marks on the vertical stitch alignment foot “V” as a guide to keep a fixed distance from the edge of the fabric.

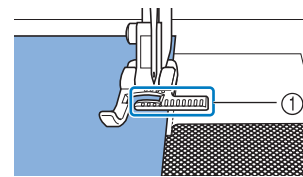

- ① Red scale marks
- * When sewing starts, a still image from the built-in camera is displayed.



Note

- While sewing, do not place anything, including your hands, within 2 mm (about 1/16 inch) from the edge of the fabric, otherwise the edge of the fabric cannot be detected correctly. When guiding the fabric with your hands, place them outside of the object-free area and more than 2 mm (about 1/16 inch) from the edge of the fabric.

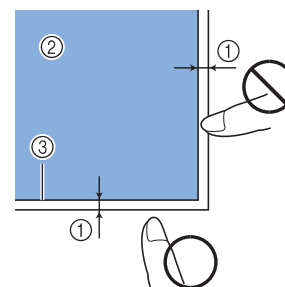

- ① Approximately 2 mm (about 1/16 inch)
- ② Fabric
- ③ Edge of fabric

- 13** When sewing is between 1 and 2 cm (about 3/8 and 3/4 inch) from the edge of the fabric, sewing stops automatically and the following message appears. To stop sewing, press  .

* When this message appears, edge sewing (with the seam wizard function) is canceled.



Note

- To continue sewing to the edge of the fabric, do not press  when the message shown above appears. With the above message displayed, press the “Start/Stop” button to sew.



Memo

- When edge sewing is finished, store the edge sewing sheet affixed to the transparent sheet in order to prevent it from collecting dust.



Chapter 4

Character/Decorative Stitches

SELECTING STITCH PATTERNS	146
■ Stitch Selection Screens	147
Selecting Decorative Stitch Patterns/7mm Decorative Stitch Patterns/Satin Stitch Patterns/7mm Satin Stitch Patterns/ Cross Stitch/Utility Decorative Stitch Patterns	148
Alphabet Characters	148
■ Deleting Characters	150
■ Adjusting the Character Spacing	150
SEWING STITCH PATTERNS	152
Sewing Attractive Finishes	152
Basic Sewing	152
Making Adjustments	153
EDITING STITCH PATTERNS	155
■ Key Functions	155
Changing the Size	157
Changing the Length (for 7mm Satin Stitch Patterns Only)	157
Creating a Vertical Mirror Image	157
Creating a Horizontal Mirror Image	158
Sewing a Pattern Continuously	158
Changing Thread Density (for Satin Stitch Patterns Only)	158
Returning to the Beginning of the Pattern	159
Checking the Image	160
COMBINING STITCH PATTERNS	162
Before Combining	162
Combining Various Stitch Patterns	162
Combining Large and Small Stitch Patterns	164
Combining Horizontal Mirror Image Stitch Patterns	165
Combining Stitch Patterns of Different Length	165
Making Step Stitch Patterns (for 7mm Satin Stitch Patterns Only)	166
■ More Examples	168
USING THE MEMORY FUNCTION	169
Stitch Data Precautions	169
■ Types of Stitch Data that can be Used	169
■ Types of USB Devices/Media that can be Used	169
■ Computers and Operating Systems with the Following Specifications can be Used	169
■ Precautions on Using the Computer to Create and Save Data	169
■ Trademarks	170
Saving Stitch Patterns in the Machine's Memory	171
■ If the Memory is Full	172
Saving Stitch Patterns to USB Media	174
Saving Stitch Patterns in the Computer	175
Retrieving Stitch Patterns from the Machine's Memory	176
Recalling from USB Media	177
Recalling from the Computer	179

SELECTING STITCH PATTERNS

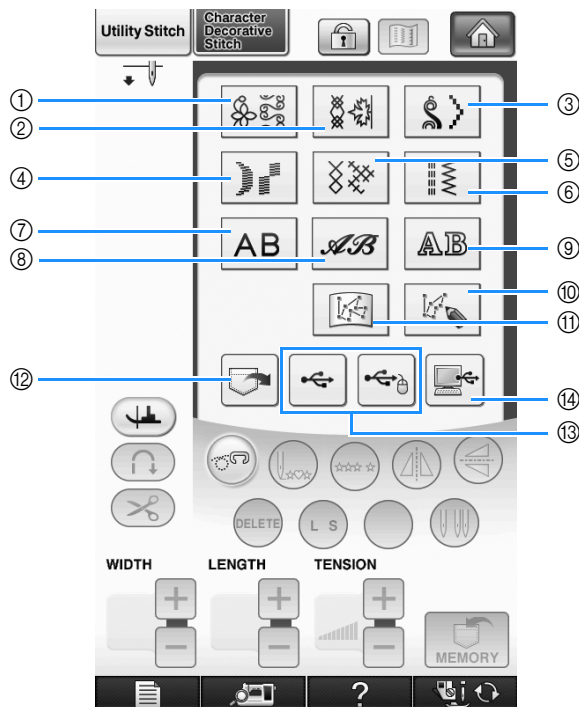

Press , then  to display the screen below.



- ① Decorative stitch patterns
- ② 7mm decorative stitch patterns. You can set stitch length and width.
- ③ Satin stitch patterns
- ④ 7mm satin stitch patterns. You can set stitch length and width.
- ⑤ Cross stitch
- ⑥ Utility decorative stitch patterns
- ⑦ Alphabet characters (gothic font)
- ⑧ Alphabet characters (handwriting font)
- ⑨ Alphabet characters (outline)
- ⑩ Press this key to create your own stitches with the “MY CUSTOM STITCH™” function (see page 316)
- ⑪ Patterns stored in “MY CUSTOM STITCH™” (see page 323)
- ⑫ Patterns saved in the machine’s memory (see page 176)
- ⑬ Patterns saved in USB media (see page 177)
- ⑭ Patterns saved on the computer (see page 179)



Note

- If the screen is locked (), unlock the screen by pressing  . While the screen is locked, no other key can be operated.

Stitch Selection Screens

There are 9 categories of Character/Decorative stitch patterns. If a page number such as $\frac{1}{2}$ appears, there is more than one stitch selection screen for that category.

Decorative Stitch Patterns

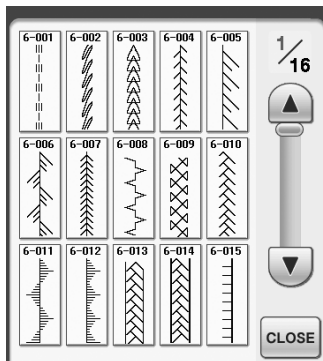

7mm Decorative Stitch Patterns

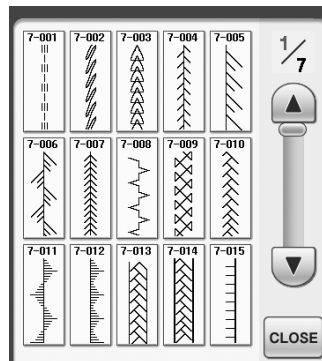

Satin Stitch Patterns

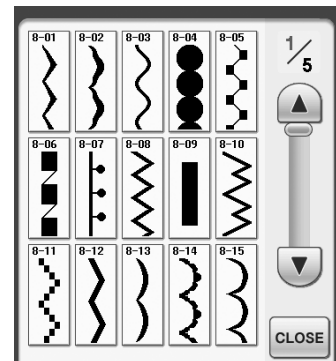

7mm Satin Stitch Patterns

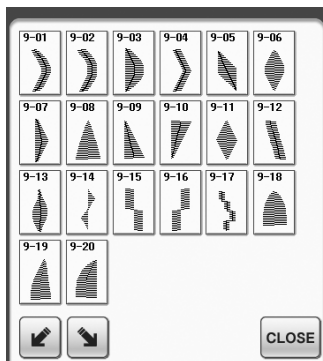

Cross Stitch

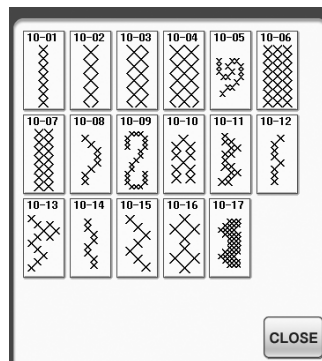

Utility Decorative Stitch Patterns

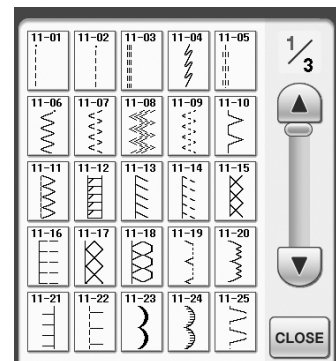

Alphabet Characters
(Gothic Font)



Alphabet Characters
(Handwriting Font)

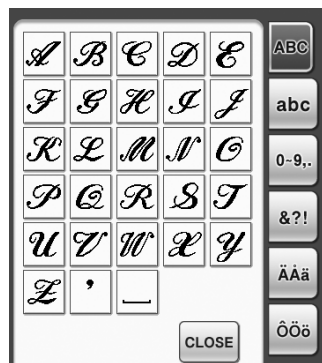



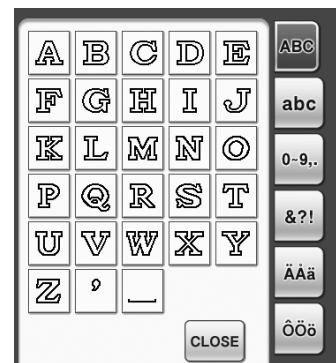

Alphabet Characters
(Outline)



Selecting Decorative Stitch Patterns/7mm Decorative Stitch Patterns/Satin Stitch Patterns/7mm Satin Stitch Patterns/ Cross Stitch/Utility Decorative Stitch Patterns

1 Select the category of the pattern you want to sew.

2 Press the key of the stitch pattern you want to sew.

- * Press  to view the next page.
- * Press  to view the previous page.
- * Touch the bar that appears between  and  to leap multiple pages at one time.
- * To select a different stitch pattern, press  .
When the current stitch pattern is erased, select the new stitch pattern.

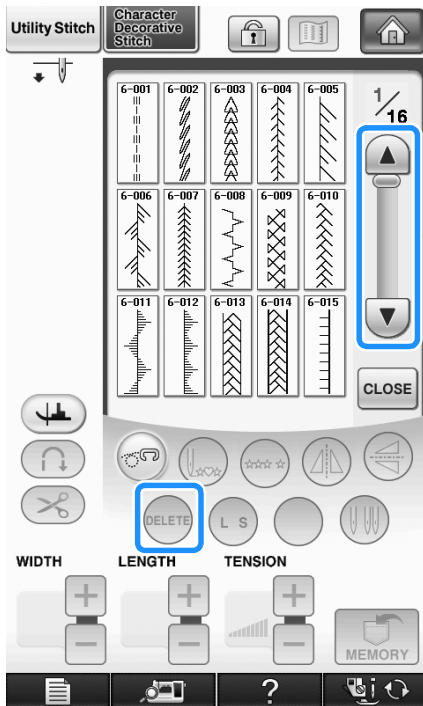

→ The selected pattern is displayed.

Alphabet Characters

Example: Entering “Blue Sky”.

1 Press ,  or  to select a font.

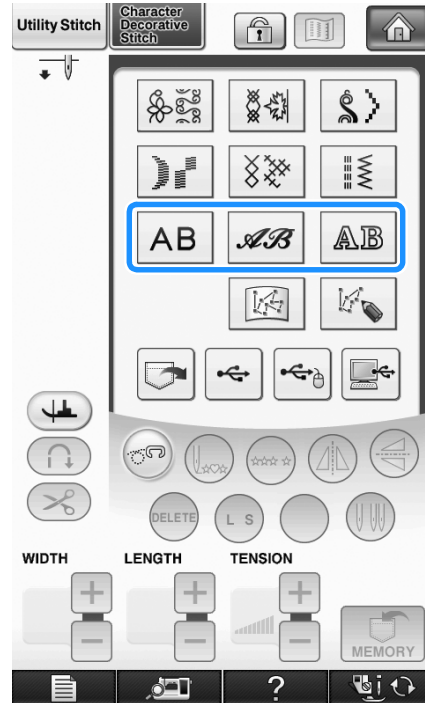

Memo

- There are three fonts for alphabet character stitching.

2 Press to change the selection screens.

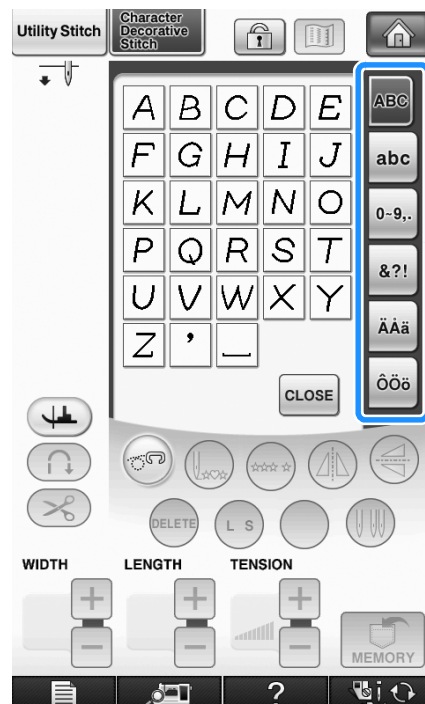

3 Press **ABC** and then enter "B".

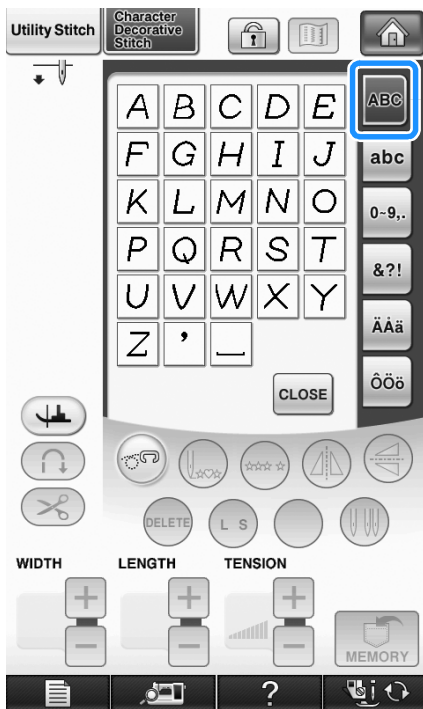

4 Press **abc** and then enter "lue".



5 Press **_** to enter a space.

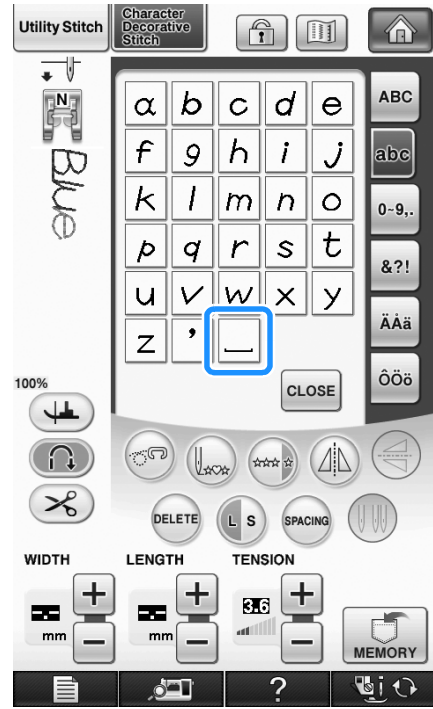

6 Press **ABC** again and enter "S".



- ① Jumping stitch
- * Remove the jumping stitches after sewing.

4

Character/Decorative Stitches

7 Press **abc** and then enter “ky”.

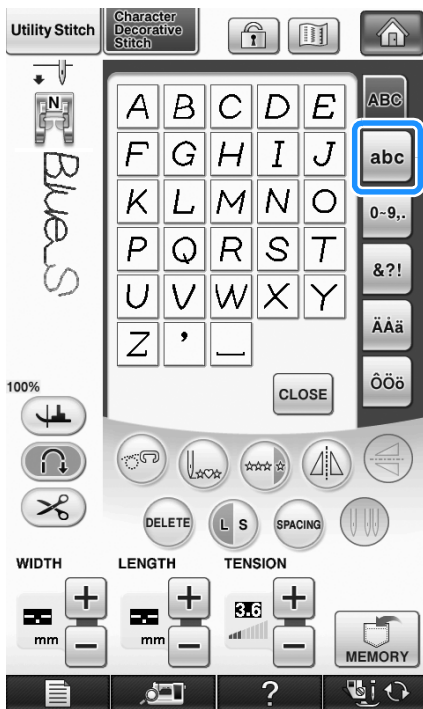

* If you want to continue entering characters in a different font, press **CLOSE**, and then repeat from step 1.

■ Deleting Characters

1 Press **DELETE** to delete the last character.



Memo

- Characters are deleted individually starting with the last character entered.

2 Select the correct character.

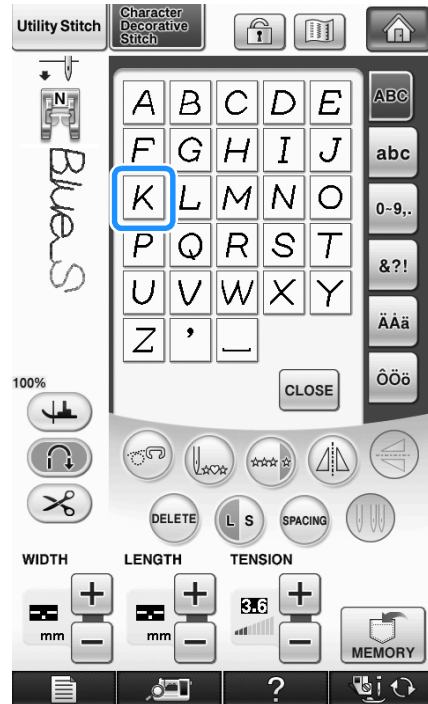

■ Adjusting the Character Spacing

The space between the characters can be adjusted.

1 Press **SPACING**.



→ The character spacing window appears.

2 Press **-** **+** to adjust character spacing.

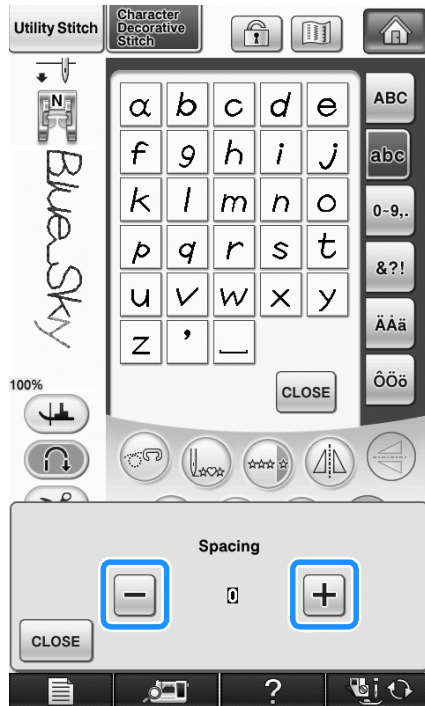

- * Press **+** to increase the character spacing and press **-** to decrease the character spacing.

Example:

- * Each setting equals a specific distance between characters.

10 Blue Sky

Value	mm
0	0
1	0.18
2	0.36
3	0.54
4	0.72
5	0.9
6	1.08
7	1.26
8	1.44
9	1.62
10	1.8

Memo

- The default setting is "0". No number less than "0" can be set.
- Changing character spacing by this method, pertains to all characters. Spacing changes are valid not only while entering characters but also before and after the entering of characters.

SEWING STITCH PATTERNS

Sewing Attractive Finishes

To achieve attractive results when sewing character/decorative stitches, check the table below for the proper fabric/needle/thread combinations.



Note

- Other factors, such as fabric thickness, stabilizer material, etc., also have an effect on the stitch, so you should always sew a few trial stitches before beginning your project.
- When sewing satin stitch patterns, there may be shrinking or bunching of stitches, so be sure to attach a stabilizer material.
- Guide the fabric with your hand to keep the fabric feeding straight and even during sewing.

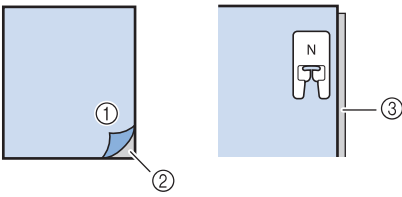
Fabric	When sewing on stretch fabrics, lightweight fabrics, or fabrics with coarse weaves, attach stabilizer on the wrong side of the fabric. If you do not wish to do so, place the fabric on a thin paper such as tracing paper.  ① Fabric ② Stabilizer ③ Thin paper
Thread	#50 - #60
Needle	With lightweight, regular, or stretch fabrics: the Ball point needle (golden colored) With heavyweight fabrics: home sewing machine needle 90/14
Presser foot	Monogramming foot "N". Using another presser foot may give inferior results.

Basic Sewing

- 1 Select a stitch pattern.
- 2 Attach monogramming foot "N".
- 3 Place the fabric under the presser foot, pull the upper thread out to the side, and then lower the presser foot.

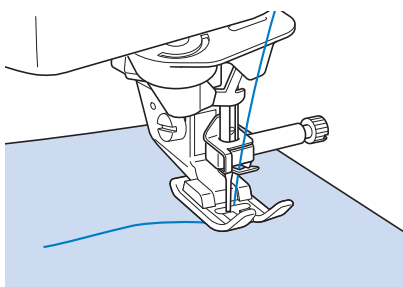

- 4 Press the "Start/Stop" button to start sewing.

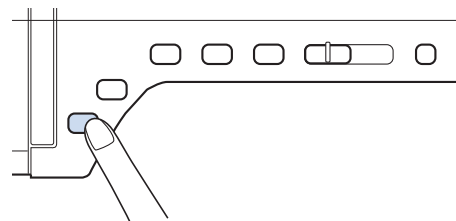

CAUTION

- When sewing 7 mm satin stitch patterns and the stitches are bunched, lengthen the stitch length. If you continue sewing when the stitches are bunched, the needle may bend or break ("Setting the Stitch Length" on page 67).

Memo

- If the fabric is pulled or pushed during sewing, the pattern may not turn out correctly. Also, depending on the pattern, there may be movement to the left and right as well as front and back. Guide the fabric with your hand to keep the fabric feeding straight and even during sewing.

5 Press the “Start/Stop” button to stop sewing.

6 Press the “Reverse/Reinforcement Stitch” button to sew reinforcement stitches.

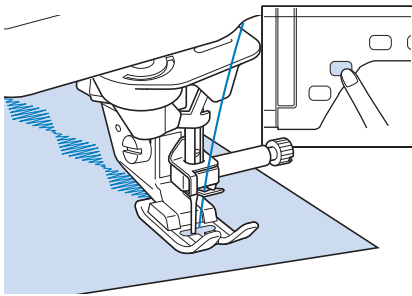
**Memo**

- When sewing character stitches, the machine automatically sews reinforcement stitches at the beginning and end of each character.

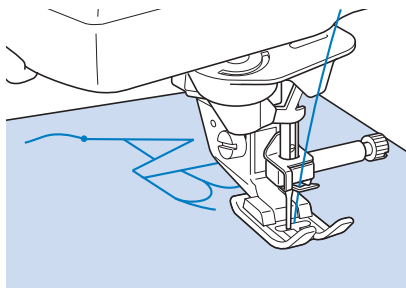

- When sewing is completed, trim any excess thread between letters.

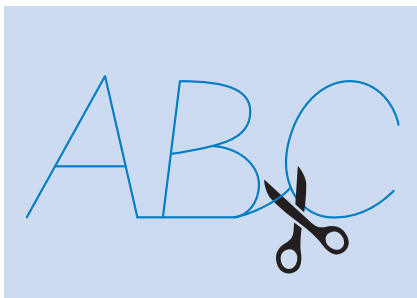

**Note**

- When sewing some patterns, the needle will temporarily pause in the raised position while the fabric is fed due to the operation of the needle bar separation mechanism which is used in this machine. At such times, a clicking sound different from the sound generated during sewing will be heard. This sound is normal and is not the sign of a malfunction.

Making Adjustments

Your stitch pattern may sometimes turn out poorly, depending on the type or thickness of fabric, the stabilizer material used, sewing speed, etc. If your sewing does not turn out well, sew trial stitches using the same conditions as the real sewing, and adjust the stitch pattern as explained below. If the pattern does not turn out well even after making

adjustments based on the  pattern, make adjustments for each pattern individually.

1 Press  and select  on 16/16.

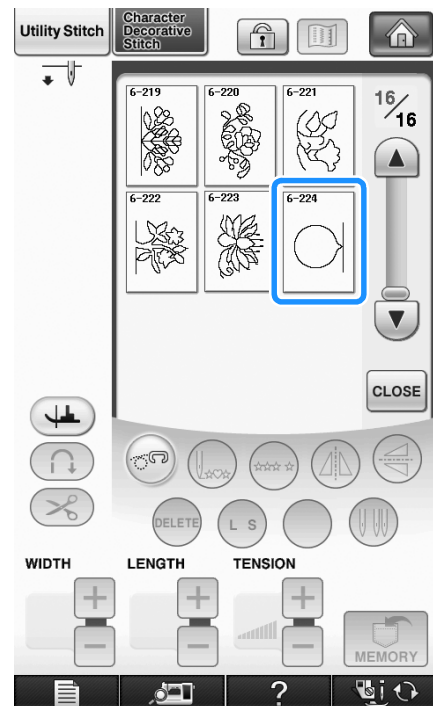

2 Attach monogramming foot “N” and sew the pattern.

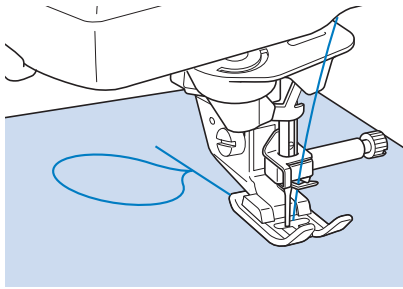

3 Compare the finished pattern to the illustration of the correct pattern below.

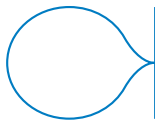

4 Press , and then adjust the pattern with the “Fine Adjust Vert.” or “Fine Adjust Horiz.” displays.

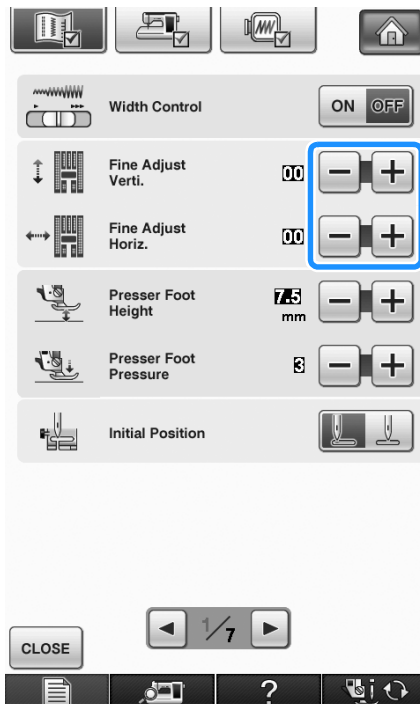

* If the pattern is bunched:

Press  in the “Fine Adjust Vert.” display.

→ The displayed value increases each time the button is pressed and the pattern will lengthen.



* If the pattern has gaps:

Press  in the “Fine Adjust Vert.” display.

→ The displayed value decreases each time the button is pressed and the pattern will shorten.



* If the pattern is skewed to the left:

Press  in the “Fine Adjust Horiz.” display.

→ The displayed value increases each time the button is pressed and the pattern will slide to the right.

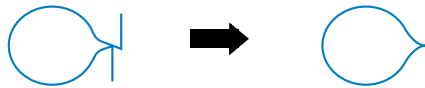

* If the pattern is skewed to the right:

Press  in the “Fine Adjust Horiz.” display.

→ The displayed value decreases each time the button is pressed and the pattern will slide to the left.

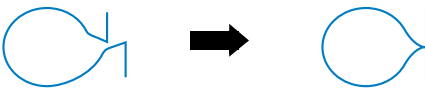

5 Sew the stitch pattern again.

* If the stitch pattern still comes out poorly, make adjustments again. Adjust until the stitch pattern comes out correctly.

 **Memo**

- You can sew with the setting screen on the display.

6 Press  to return to the original screen.

EDITING STITCH PATTERNS

Key Functions









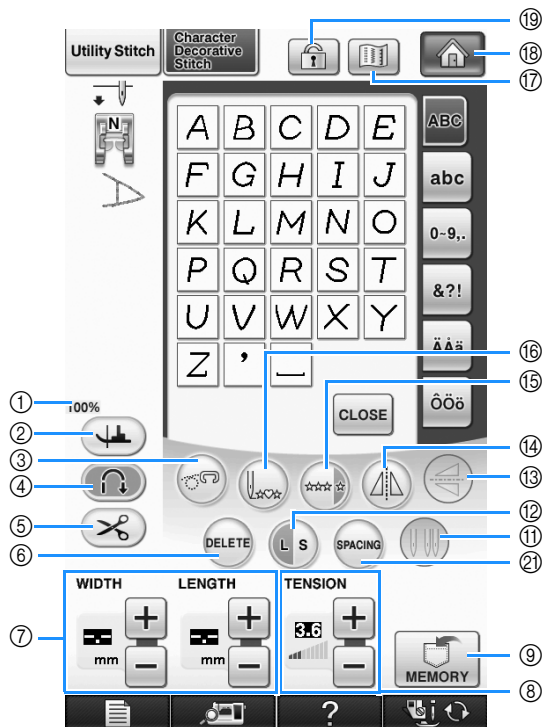
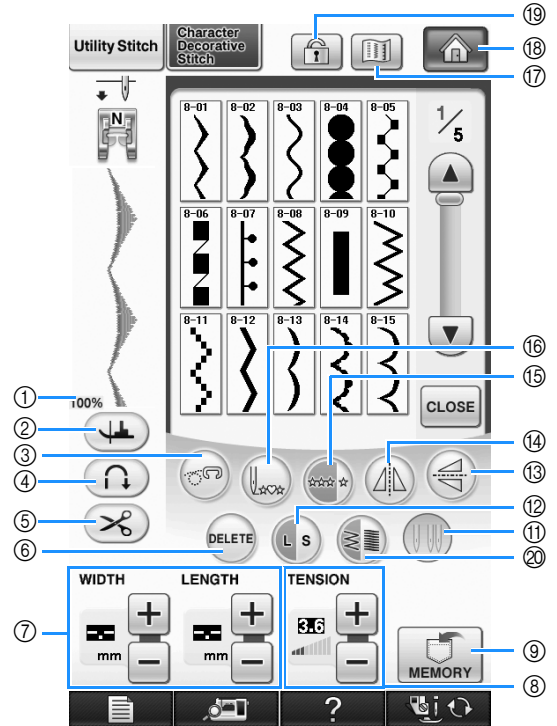
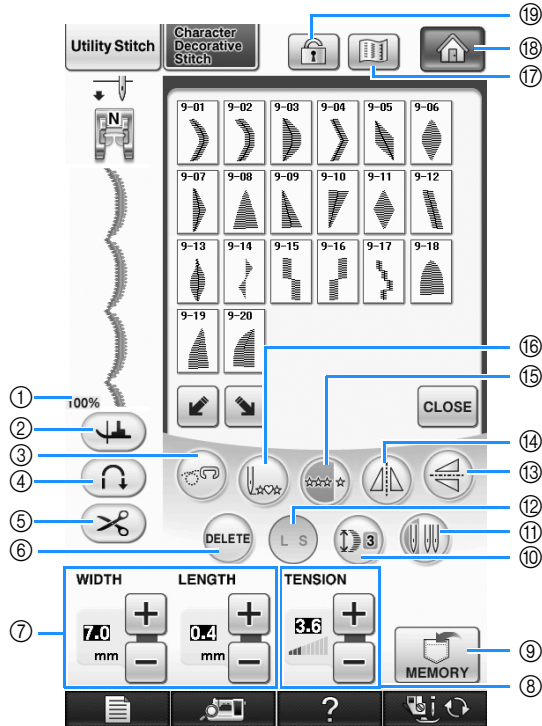







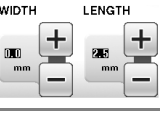



You can create just the finish you want using the editing functions. Make patterns larger or smaller, make mirror images, etc.



Note

- Some editing functions cannot be used with certain stitch patterns. Only the functions for the displayed keys are available when a pattern is selected.



No.	Display	Key Name	Explanation	Page
①		Pattern display size	Show the approximate size of the pattern selected. 100% : Nearly the same size as the sewn pattern 50% : 1/2 the size of the sewn pattern 25% : 1/4 the size of the sewn pattern * The actual size of the sewn pattern may differ depending on the type of fabric and thread that is used.	79
②		Pivot key	Press this key to select the pivot setting. When the pivot setting is selected, stopping the machine lowers the needle and slightly raises the presser foot automatically. In addition, when sewing is restarted, the presser foot is automatically lowered. <ul style="list-style-type: none"> • If this key appears as , the pivot function cannot be used. • Be sure the needle position on page 3 of Machine Settings is set to the down position. 	72
③		Free motion mode key	Press this key to enter free motion sewing mode. The feed dog is lowered and presser foot is raised to a height appropriate for free motion quilting.	105
④		Automatic reinforcement stitch key	Press this key to turn on the automatic reinforcement stitching mode.	69
⑤		Automatic thread cutting key	Press this key to turn on the automatic thread cutting mode.	69
⑥		Delete key	When you make a mistake selecting a stitch pattern, use this key to delete the mistake. When you make a mistake in combining stitch patterns, use this key to delete stitch patterns.	148, 150
⑦		Stitch width and stitch length key	Shows the stitch width and stitch length of the selected stitch pattern. The machine default settings are highlighted.	66-67
⑧		Thread tension key	Shows the thread tension setting for the selected stitch pattern. The machine default settings are highlighted	67
⑨		Memory key	Use this key to save stitch pattern combinations.	171-173
⑩		Elongation key	When 7mm satin stitch patterns are selected, press this key to choose from 5 automatic length settings, without changing the stitch zigzag width or stitch length settings.	157
⑪		Needle mode selection key (Single/Double)	Press this key to choose single needle sewing or twin needle sewing.	49
⑫		Size selection key	Use this key to select the size of the stitch pattern (large, small).	157
⑬		Vertical mirror image key	After selecting the stitch pattern, use this key to create a vertical mirror image of the stitch pattern.	157
⑭		Horizontal mirror image key	After selecting the stitch pattern, use this key to create a horizontal mirror image of the stitch pattern.	158
⑮		Single/Repeat sewing key	Press this key to choose single stitches or continuous stitches.	158
⑯		Back to beginning key	When sewing is stopped, press this key to return to the beginning of the pattern.	159
⑰		Image key	Press this key to display an enlarged image of the selected stitch pattern.	160
⑱		Home key	Press this key to return to the home page screen.	14
⑲		Screen lock key	Press this key to lock the screen. When the screen is locked, the various settings, such as the stitch width and stitch length, are locked and cannot be changed. Press this key again to unlock the settings.	74
⑳		Thread density key	After selecting the stitch pattern, use this key to change the thread density of the pattern.	158
㉑		Character spacing key	Press this key to change the spacing of character patterns.	150

Changing the Size

Select a stitch pattern, then press  to change the size of the stitch pattern. The stitch pattern will be sewn in the size highlighted on the key.



Memo

- If you continue entering stitch patterns after changing the size, those patterns will also be sewn in that size.
- You cannot change the size of combined stitch patterns once the stitch pattern is entered.

Actual Stitch Pattern Size

* The size differs depending on the fabric and threads.



Changing the Length (for 7mm Satin Stitch Patterns Only)

When 7mm satin stitch patterns are selected, press  to choose from 5 automatic length settings, without changing the stitch zigzag width or stitch length settings.

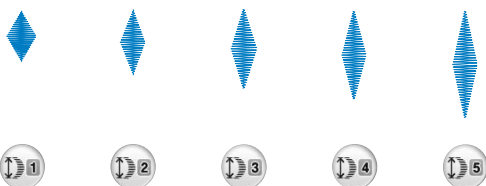

Creating a Vertical Mirror Image

To create a vertical mirror image, select a stitch pattern then press .

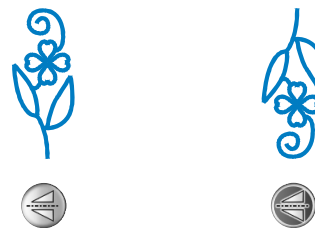

Creating a Horizontal Mirror Image

To create a horizontal mirror image, select a stitch pattern then press .

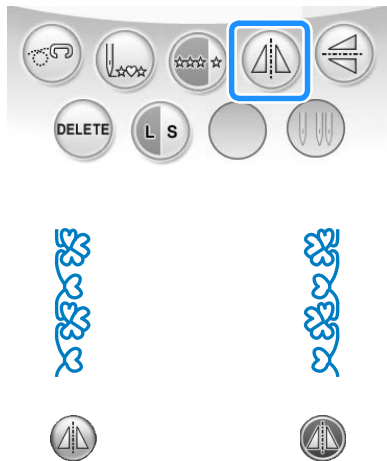

Sewing a Pattern Continuously

Press  to select continuous sewing or single stitch sewing.

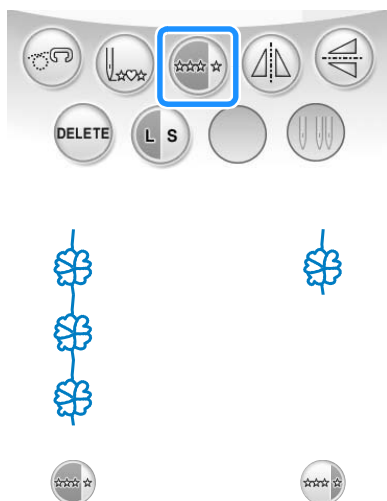

Memo



- To finish a complete motif while sewing the pattern continuously, you can press the  key while sewing. The machine will automatically stop when the motif is finished.

Changing Thread Density (for Satin Stitch Patterns Only)

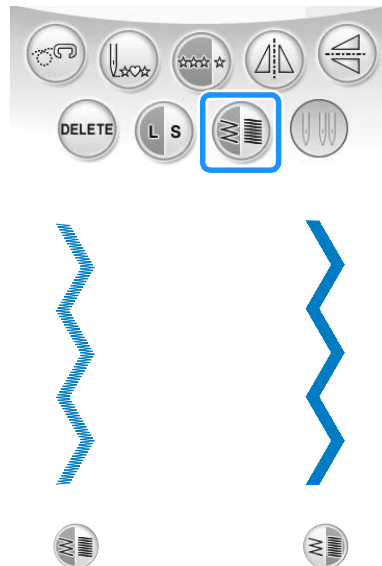
After selecting a satin stitch pattern, press  to select your preferred thread density.



CAUTION

- If the stitches bunch when thread density is changed to , return the thread density to . If you continue sewing when the stitches are bunched, the needle may bend or break.

Memo

- Even if you select a new pattern after changing the thread density, the thread density remains the same until you change it.
- You cannot change thread density for a combined pattern after additional patterns are added.

Returning to the Beginning of the Pattern

When sewing character/decorative stitches, you can return to the beginning of the pattern after trial sewing or when the stitching is sewn incorrectly.

- 1 Press the “Start/Stop” button to stop the machine, and then press .

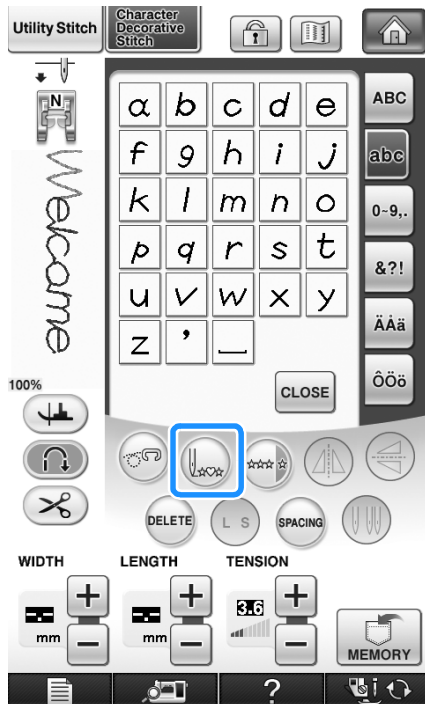

→ Sewing returns to the beginning of the selected pattern (“W”) from the point where sewing was stopped.

Memo

- If this key is pressed when sewing is stopped, patterns can be added at the end of a combined stitch pattern. (In this example, “!” is added.)

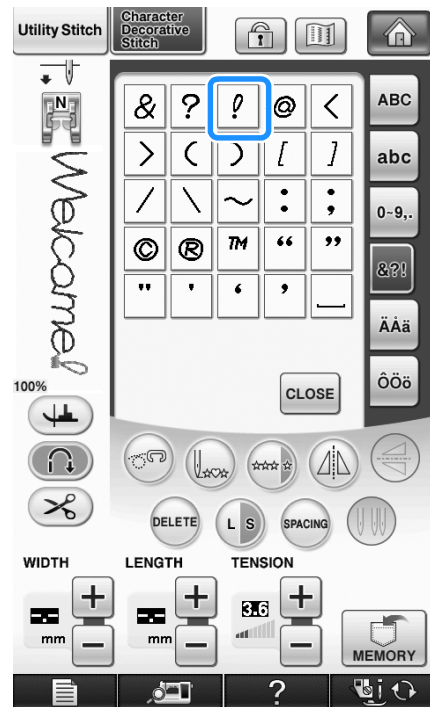

- 2 Press the “Start/Stop” button to continue sewing.

Checking the Image

You can display an approximate size image of the selected stitch pattern. You can also check and change the colors of the image on the screen.

1 Press .

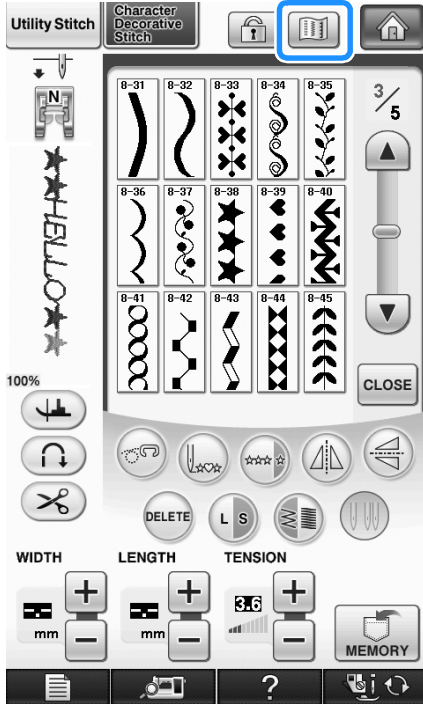

→ An image of the selected pattern is displayed.

2 Press  to change the thread color in the image to red, blue, or black.

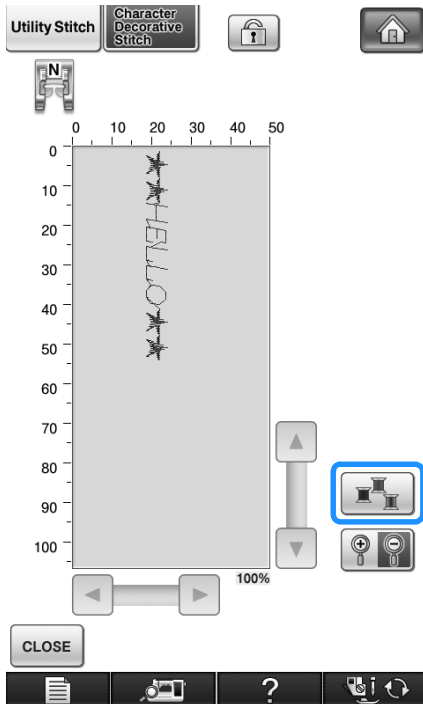

→ The color changes every time you press the button.

3 Press  to display the enlarged image.

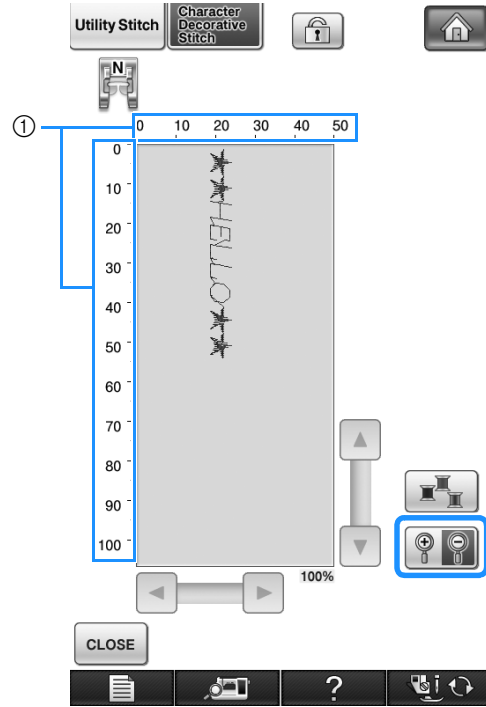

① Displays the approximate size of the pattern

4 Use  to view any part of the image that extends out of the viewable display area.

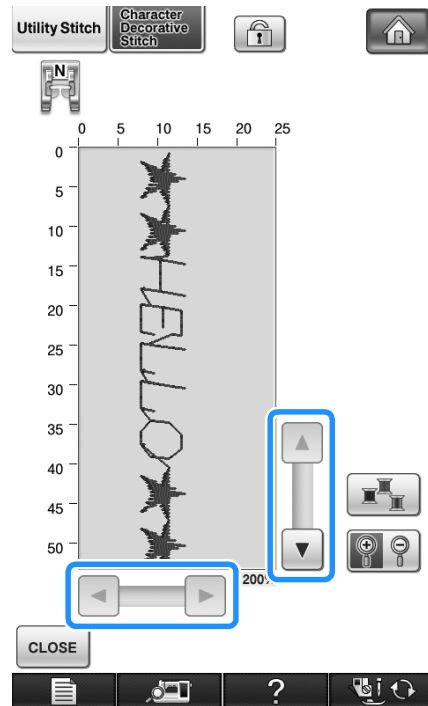

5 Press  to return to the original screen.



Memo

- You can also sew from this screen when the presser foot symbol is displayed.
 - Image of some patterns will display in default size only.
-

COMBINING STITCH PATTERNS

You can combine many varieties of stitch patterns, such as character stitches, cross stitches, satin stitches, or stitches you design with MY CUSTOM STITCH™ function (see chapter 7 for information about MY CUSTOM STITCH™). You can also combine stitch patterns of different sizes, mirror image stitch patterns, and others.

Before Combining

Single stitch sewing is automatically selected for sewing combined patterns. If you want to sew the pattern continuously, press  after finishing the stitch pattern combination.

When changing sizes, creating mirror images, or making other adjustments to a combined stitch pattern, be sure to edit the selected stitch pattern before selecting the next one. You cannot edit a stitch pattern once the next stitch pattern is selected.

Combining Various Stitch Patterns

Example:



1 Press .

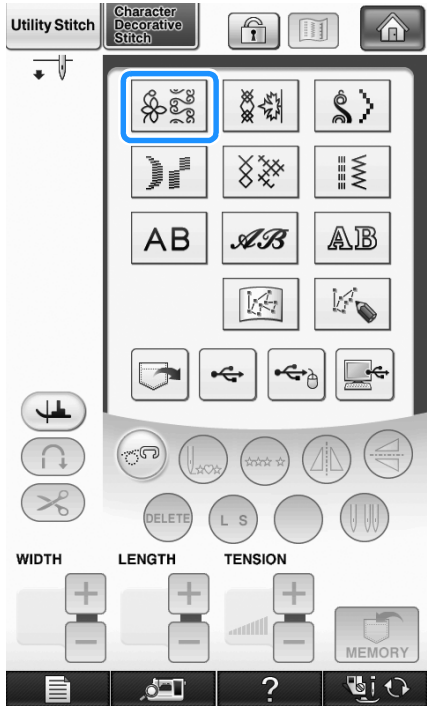

2 Select .

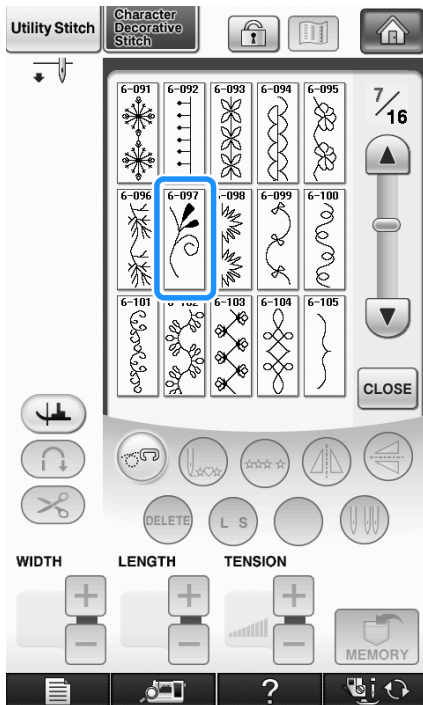

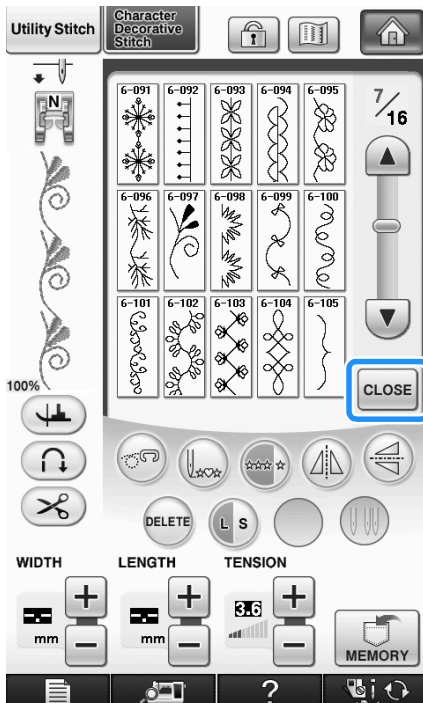

3 Press **CLOSE**.

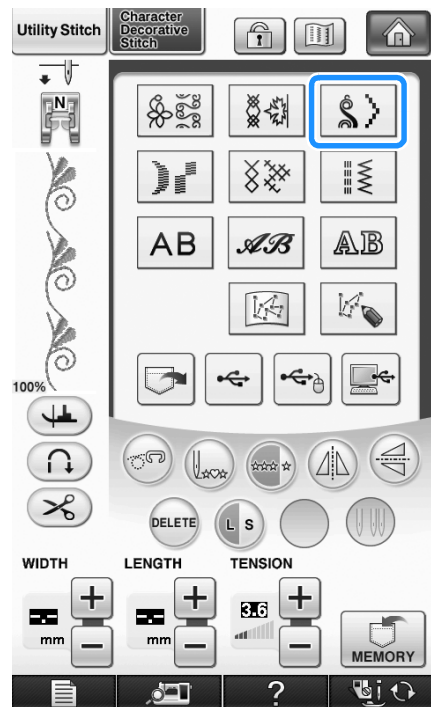

→ The display returns to the stitch selection screen.

4 Press .



5 Select .

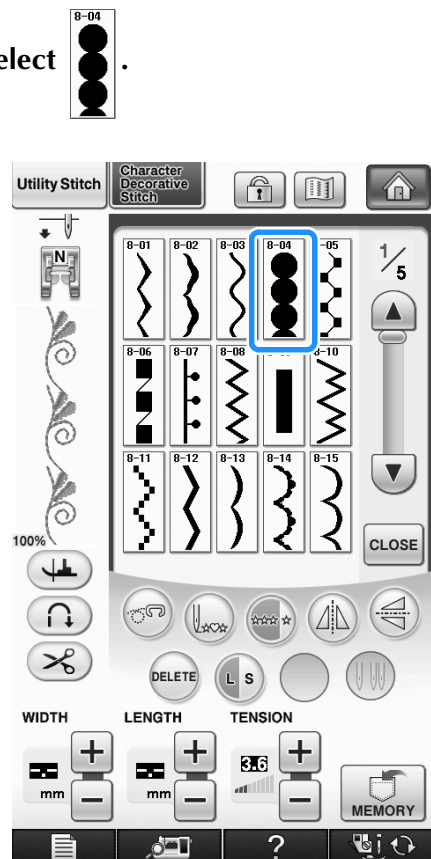

4

Character/Decorative Stitches

6 Press to sew the pattern continuously.

7 Press .

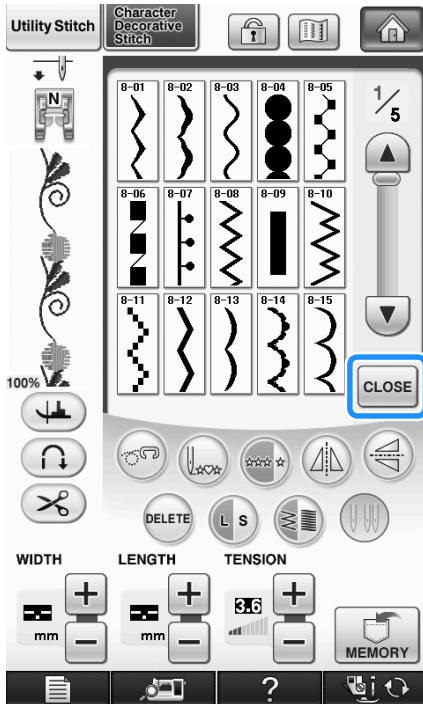

Memo

- Patterns are deleted individually starting with the last pattern entered by pressing



Combining Large and Small Stitch Patterns

Example:



1 Press .

→ The large size stitch will be selected.

2 Press again, then press to select the small size.

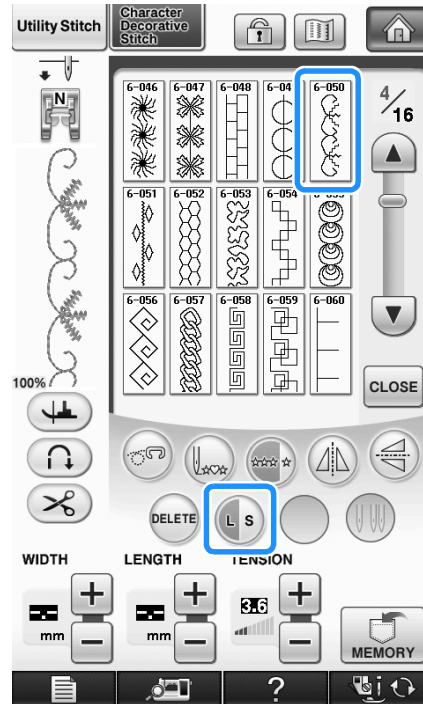

→ The pattern is displayed in a smaller size.

3 Press to sew continuously.

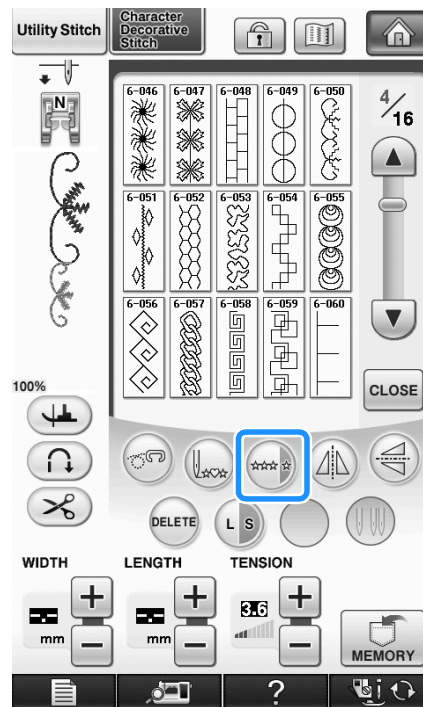



→ The entered pattern is repeated.

Combining Horizontal Mirror Image Stitch Patterns

Example:



1 Press .

2 Press  again, then press .

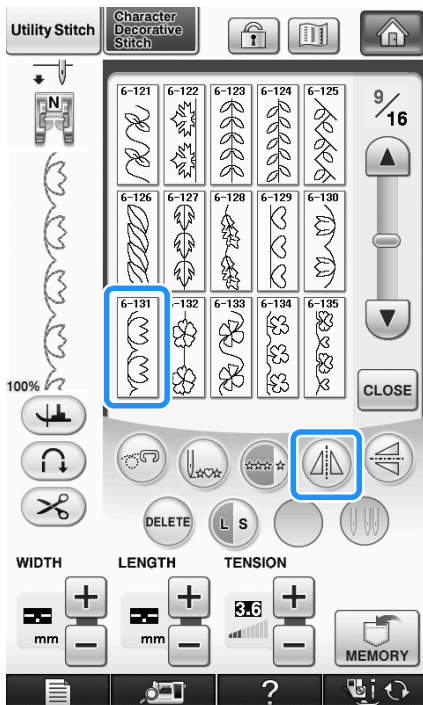

→ The pattern is flipped along a vertical axis.

3 Press .

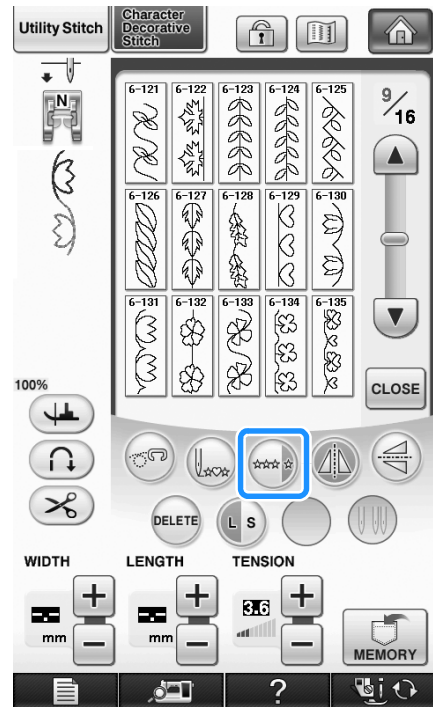



→ The entered pattern is repeated.



Combining Stitch Patterns of Different Length

Example:



1 Press , then press  once.

→ The length of the image is set to .

2 Select  again, then press  3 times.

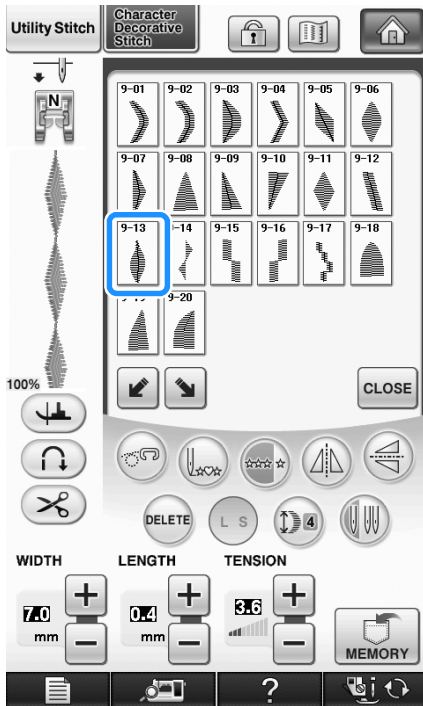

→ The length of the image is set to .

3 Press .

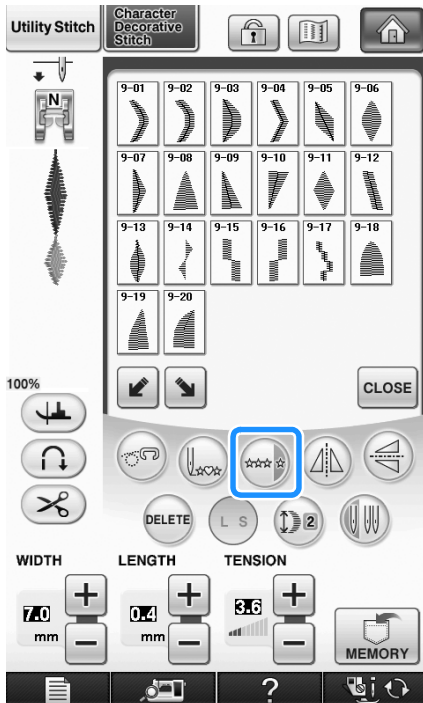



→ The entered pattern is repeated.

Making Step Stitch Patterns (for 7mm Satin Stitch Patterns Only)

You can use the   keys with 7mm satin stitch patterns to create a step effect.

Stitch patterns sewn so that they create a step effect are called step stitch patterns.

- * Press  to move the stitch pattern a distance equal to half of the stitch pattern's size to the left.
- * Press  to move the stitch pattern a distance equal to half of the stitch pattern's size to the right.

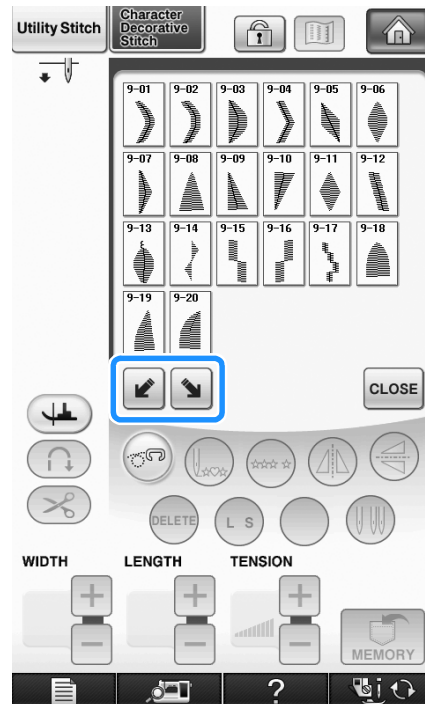

Example:



1 Press .

2 Press .



→ The next stitch pattern will move to the right.

3 Press  again.

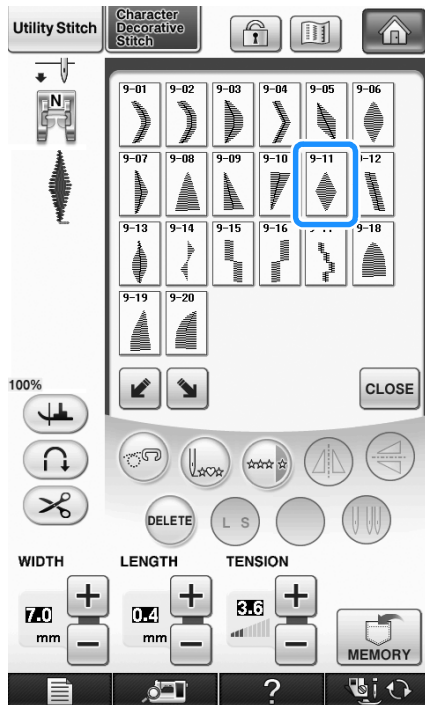

4 Press .



→ The next stitch pattern will move to the left.

5 Press .

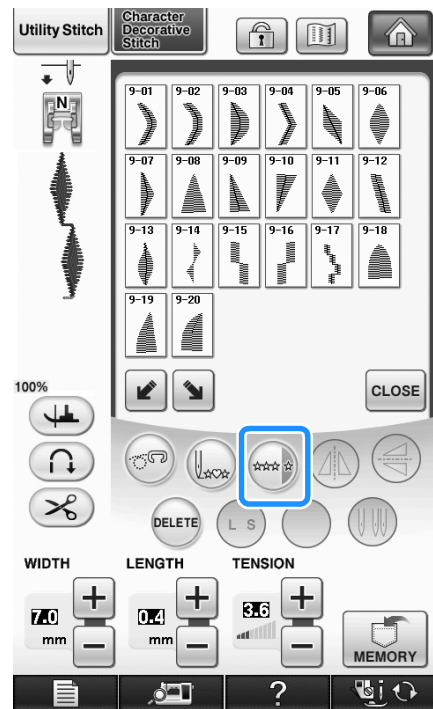

→ The entered pattern is repeated.

4

Character/Decorative Stitches

More Examples

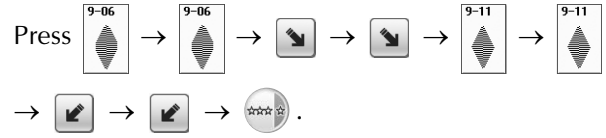
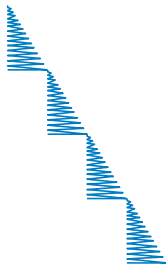
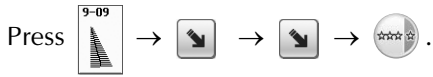
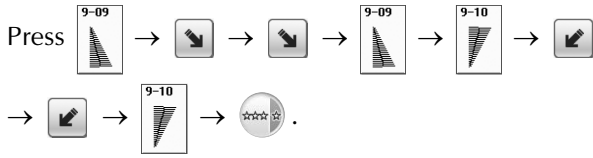
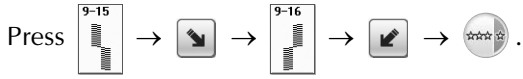

USING THE MEMORY FUNCTION

Stitch Data Precautions

Observe the following precautions when using stitch data other than that created and saved in this machine.

■ Types of Stitch Data that can be Used

- In the Character/Decorative Stitch memory, “.pmx” and “.pmu” stitch data files can be used with this machine. “.pmu” stitch data files can be retrieved; however, when the machine is used to save the file, it is saved as a “.pmx” stitch data file. Using data other than that created using this machine or the machine which create “.pmu” data file, may cause the machine to malfunction.

■ Types of USB Devices/Media that can be Used

Stitch data can be saved to or recalled from USB external media. Use external media that meets the following specifications.

- USB Flash drive (USB Flash memory)
- USB Floppy disk drive

Stitch data can be recalled only from;

- USB CD-ROM, CD-R, CD-RW drives

You can also use the following types of USB media with the USB Memory Card Reader/USB card writer module.

- Secure Digital (SD) Card
- CompactFlash
- Memory Stick
- Smart Media
- Multi Media Card (MMC)
- XD-Picture Card



Note

- Some USB media may not be usable with this machine. Please visit our website for more details.
- The access lamp will begin blinking after inserting USB Devices/Media, and it will take about 5 to 6 seconds to recognize the Devices/Media. (Time will differ depending on the USB Device/Media).

- To create file folders, use a computer.

■ Computers and Operating Systems with the Following Specifications can be Used

- Compatible models:
IBM PC with a USB port as standard equipment
IBM PC-compatible computer equipped with a USB port as standard equipment
- Compatible operating systems:
Microsoft Windows 2000/XP/Vista

■ Precautions on Using the Computer to Create and Save Data

- If the name of the stitch data file/folder cannot be identified, for example, because the name contains special characters, the file/folder is not displayed. If this occurs, change the name of the file/folder. We recommend using the 26 letters of the alphabet (uppercase and lowercase), the numbers 0 through 9, “-”, and “_”.
- Stitch data in a folder created in USB media can be retrieved.
- Do not create folders in “Removable Disk” on a computer. If stitch data is stored in a folder in “Removable Disk”, that stitch data cannot be retrieved by the machine.

■ Trademarks

- Secure Digital (SD) Card is a registered trademark or a trademark of SD Card Association.
- CompactFlash is a registered trademark or a trademark of Sandisk Corporation.
- Memory Stick is a registered trademark or a trademark of Sony Corporation.
- Smart Media is a registered trademark or a trademark of Toshiba Corporation.
- Multi Media Card (MMC) is a registered trademark or a trademark of Infineon Technologies AG.
- xD-Picture Card is a registered trademark or a trademark of Fuji Photo Film Co. Ltd.
- IBM is a registered trademark or a trademark of International Business Machines Corporation.
- Microsoft and Windows are registered trademarks or trademarks of Microsoft Corporation.

Each company whose software title is mentioned in this manual has a Software License Agreement specific to its proprietary programs.

All other brands and product names mentioned in this manual are registered trademarks of their respective companies. However, the explanations for markings such as ® and ™ are not clearly described within the text.

CAUTION

- **Before disconnecting the USB cable, click the “Unplug or Eject Hardware” icon in the taskbar of Windows® 2000 or the “Safely Remove Hardware” icon in the taskbar of Windows® XP/Windows Vista®. Then, when the removable disk can safely be removed, disconnect the USB cable from the computer and the machine.**

Windows® XP



Windows Vista®



Saving Stitch Patterns in the Machine's Memory

You can save often used stitch patterns in the machine's memory. A total of about 1 MB of stitch patterns can be saved in the machine's memory.



Note

- Do not turn the main power to OFF while the "Saving" screen is displayed. You will lose the stitch pattern you are saving.



Memo

- It takes a few seconds to save a stitch pattern.
- See page 176 for information on retrieving a saved stitch pattern.

1 Press  .



2 Press  .

- * Press  to return to the original screen without saving.



- The "Saving" screen is displayed. When the pattern is saved, the display returns to the original screen automatically.



■ If the Memory is Full

If the following screen appears while you are trying to save a pattern on the machine's memory, the memory is too full to hold the currently selected stitch pattern. To save the stitch pattern in the machine's memory, you have to delete a previously saved stitch pattern.

1 Press **DELETE**.

* Press **CANCEL** to return to the original screen without saving.

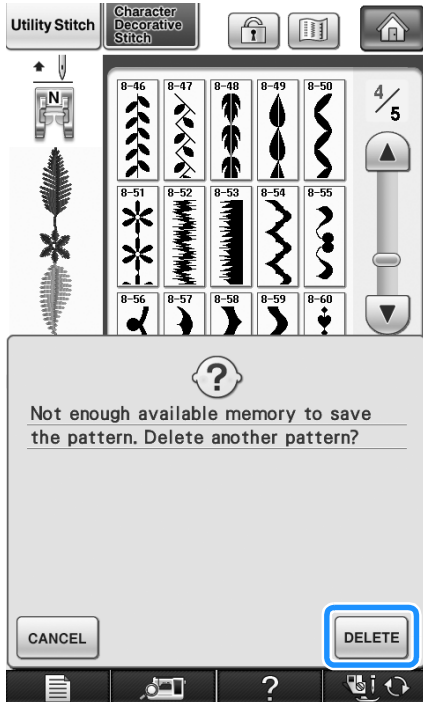

2 Choose a stitch pattern to delete.

* Press **CLOSE** if you decide not to delete the stitch pattern.

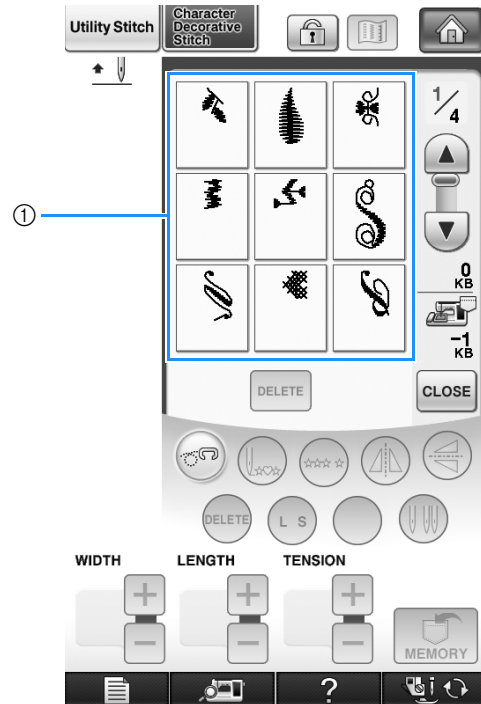

① Pockets holding saved stitch patterns

3 Press **DELETE**.

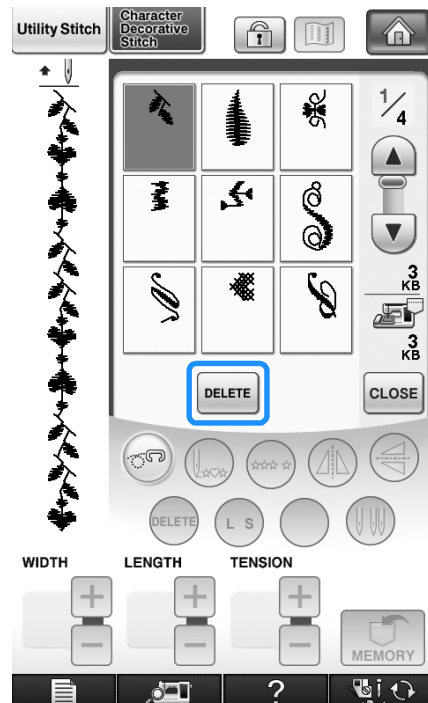

→ A confirmation message appears.

4 Press **OK**.

* If you decide not to delete the stitch pattern, press

CANCEL.

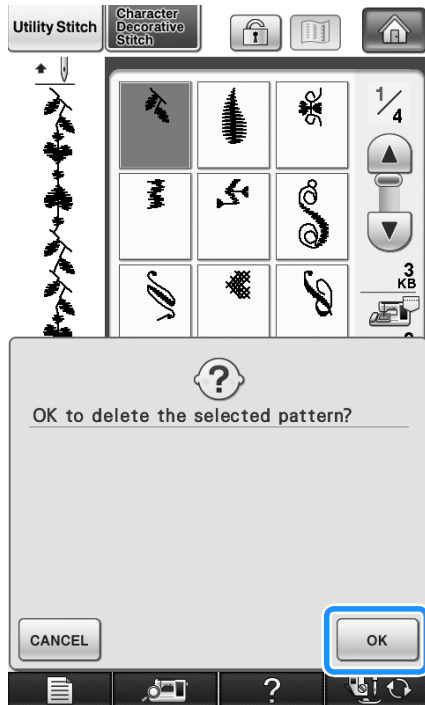

→ The machine deletes the stitch pattern, then automatically saves the new stitch pattern.

Saving Stitch Patterns to USB Media

When sending stitch patterns from the machine to USB media, plug the USB media into the machine's top USB port.

Memo

- USB media is commercially available, but some USB media may not be usable with this machine. Please visit our website for more details.
- Depending on the type of USB media being used, either directly plug the USB device into the machine's USB port or plug the USB media Reader/Writer into the machine's USB port.
- The USB media can be inserted or removed at any time.

1 Press  .



2 Insert the USB media into the primary (top) USB port on the machine.

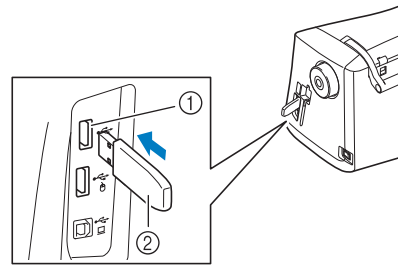

- ① Primary (top) USB port for media
- ② USB media

Note

- The processing speed may vary by port selection and quantity of data. You can also plug a USB media into the center port, but the primary (top) USB port will process the data faster. It is recommended to use the primary (top) USB port.
- Two USB media cannot be used with this machine at the same time. If two USB media are inserted, only the USB media inserted first is detected.

3 Press .

* Press **CLOSE** to return to the original screen without saving.



→ The "Saving" screen is displayed. When the pattern is saved, the display returns to the original screen automatically.



Note

- Do not insert or remove USB media while "Saving" screen is displayed. You will lose some or all of the pattern you are saving.

Saving Stitch Patterns in the Computer

Using the included USB cable, the machine can be connected to your computer, and the stitch patterns can be temporarily retrieved from and saved in the "Removable Disk" folder in your computer.



Note

- Do not turn the main power to OFF while the "Saving" screen is displayed. You will lose the stitch pattern you are saving.

1 Plug the USB cable connector into the corresponding USB ports for the computer and for the machine.

2 Turn on your computer and select "Computer (My computer)".

* The USB cable can be plugged into the USB ports on the computer and machine whether or not they are turned on.

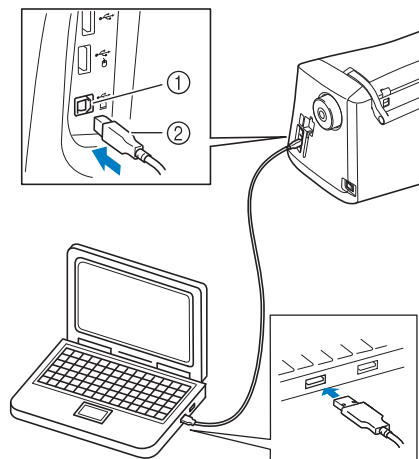

- ① USB port for computer
- ② USB cable connector

→ The "Removable Disk" icon will appear in "Computer (My computer)" on the computer.



Note

- The connectors on the USB cable can only be inserted into a port in one direction. If it is difficult to insert the connector, do not insert it with force and check the orientation of the connector.
- For details on the position of the USB port on the computer (or USB hub), refer to the instruction manual for the corresponding equipment.

3 Press .



4 Press .

* Press **CLOSE** to return to the original screen without saving.



→ The stitch pattern will be temporarily saved to "Removable Disk" under "Computer (My computer)".

5 Select the stitch pattern's .pmx file and copy the file to the computer.

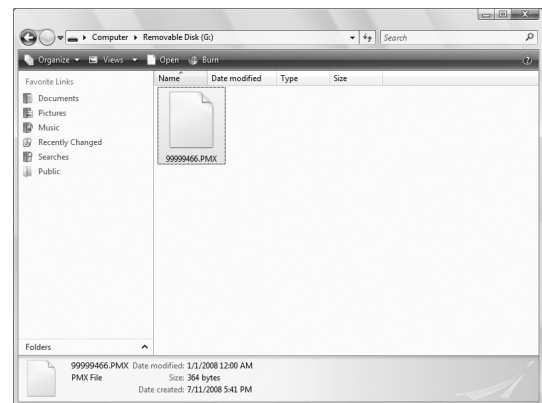

Note

- Do not turn off the machine while the "Saving" screen is showing. You may lose the data.

Retrieving Stitch Patterns from the Machine's Memory

1 Press .

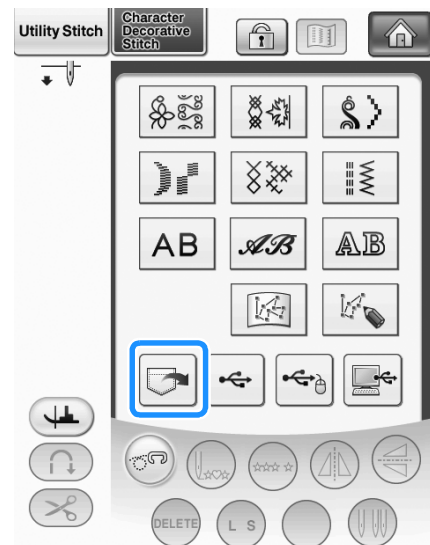

→ The pocket selection screen appears.

2 Choose a stitch pattern to retrieve.

- * If the entire saved stitch pattern is not displayed, press the thumbnail.
- * Press **CLOSE** to return to the original screen without saving.

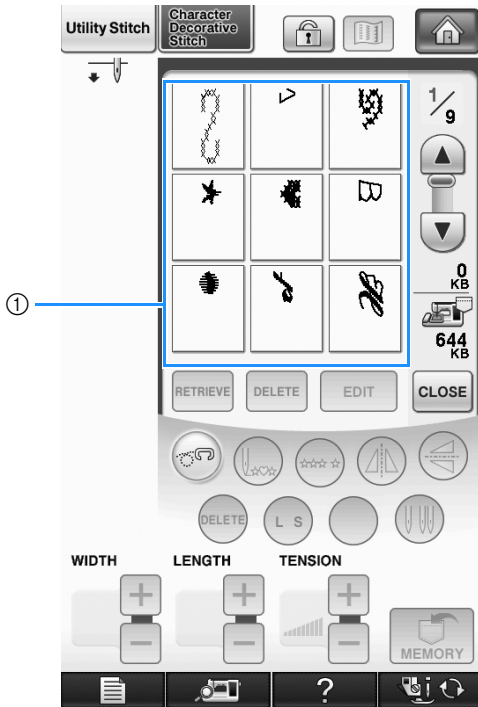

① Saved stitch patterns

3 Press **RETRIEVE**.

- * Press **DELETE** to delete the stitch pattern.

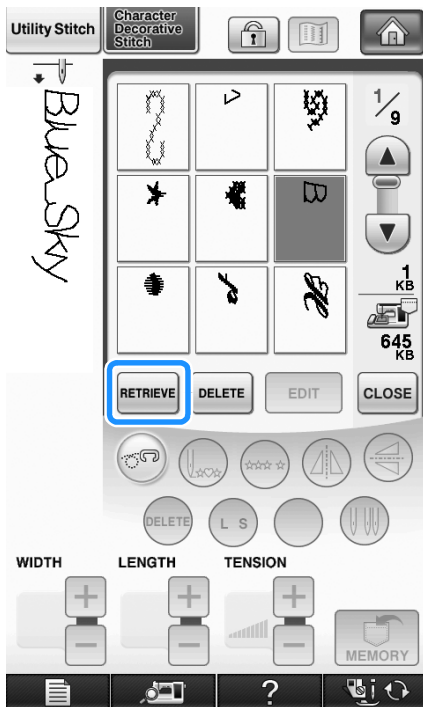

→ The selected stitch pattern is retrieved and the sewing screen will be displayed.

Recalling from USB Media

You can recall a specific stitch pattern from either direct USB media or a folder in the USB media. If the stitch pattern is in a folder, check each folder to find the stitch pattern.

1 Insert the USB Media into the primary (top) USB port on the machine (see page 174).

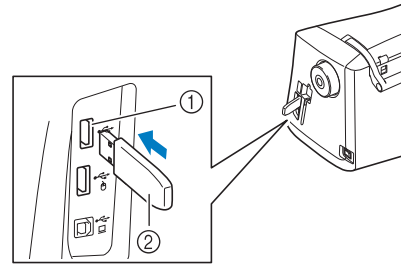

- ① Primary (top) USB port for media
- ② USB media

2 Press **USB**.

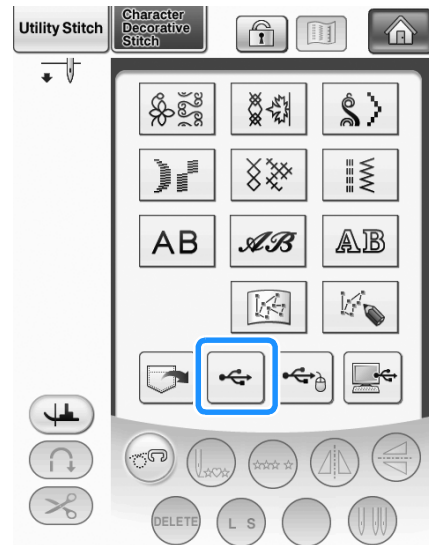

→ Stitch patterns and a folder in a top folder are displayed.

3 Press  when there is a subfolder to sort two or more stitch patterns to USB media, the stitch pattern in the subfolder is displayed.

* Press **CLOSE** to return to the original screen without recalling.

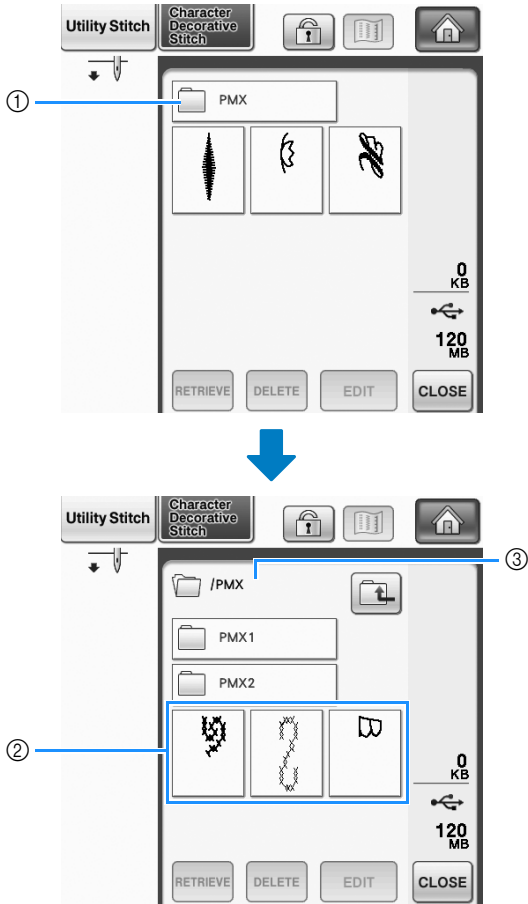

- ① Folder name
- ② Stitch patterns in a folder show only the first pattern of any combined patterns.
- ③ Path
 - The path shows the current folder at the top of the list.
 - Stitch patterns and a subfolder within a folder are displayed.
- * Press  to return to the previous folder.
- * Use the computer to create folders. Folders cannot be created with the machine.

4 Press the key of the stitch pattern you want to recall.

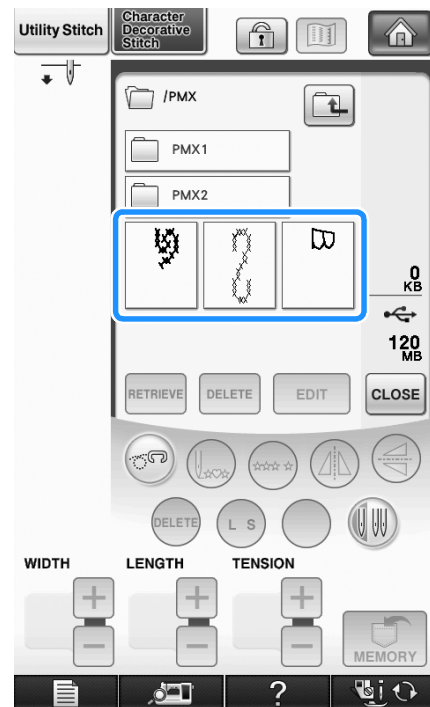

5 Press **RETRIEVE**.

* Press **DELETE** to delete the stitch pattern. The pattern will be deleted from the USB media.

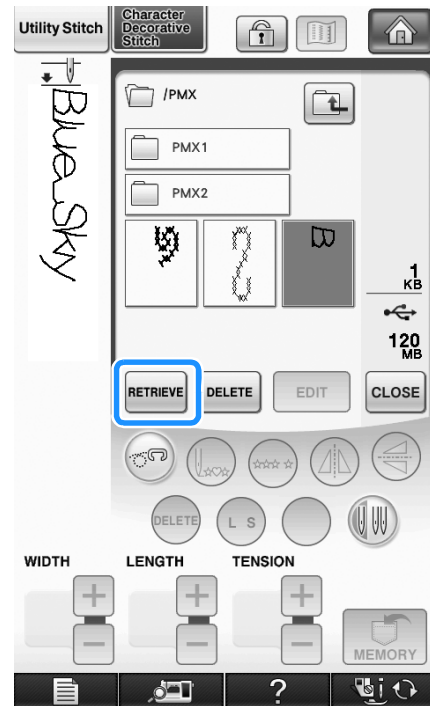

→ The selected stitch pattern is recalled and the sewing screen will be displayed.

Recalling from the Computer

- 1 Plug the USB cable connector into the corresponding USB ports for the computer and for the machine (see page 175).
- 2 On the computer, open "Computer (My computer)" then go to "Removable Disk".

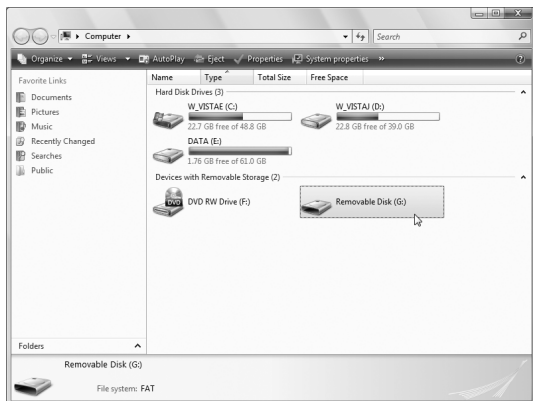

- 3 Move/copy the pattern data to "Removable Disk".

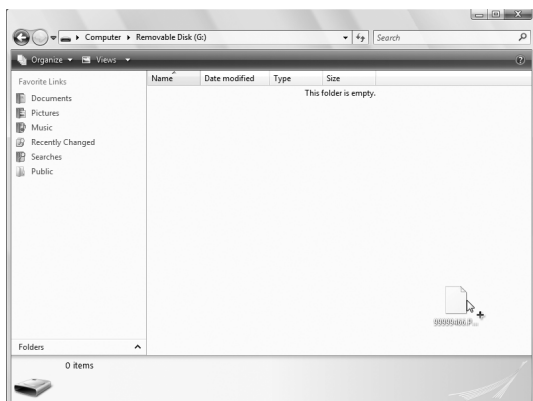

→ Stitch pattern data in "Removable Disk" is written to the machine.

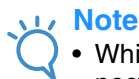

Note

- While data is being written, do not disconnect the USB cable.
- Do not create folders within "Removable Disk". Since folders are not displayed, stitch pattern data within folders cannot be recalled.

- 4 Press

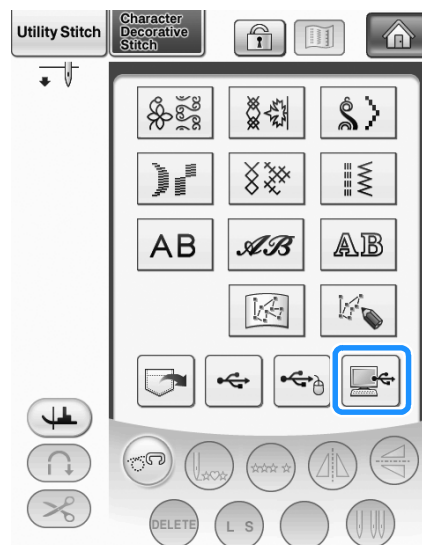

→ The stitch patterns in the computer are displayed on the selection screen.

- 5 Press the key of the stitch pattern you want to recall.

* Press **CLOSE** to return to the original screen without recalling.

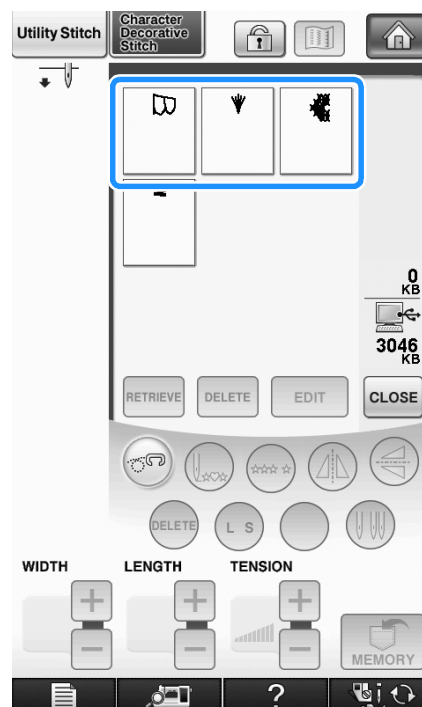

4

6 Press **RETRIEVE**.

- * Press **DELETE** to delete the stitch pattern.
The pattern will be deleted from the “Removable Disk” folder in your computer.

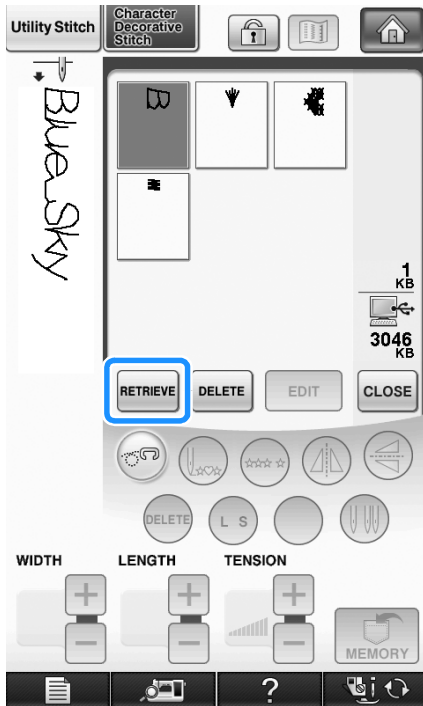

→ The selected stitch pattern is recalled and the sewing screen will be displayed.

Note

- The pattern recalled from the computer is only temporarily written to the machine. It is erased from the machine when the machine is turned off. If you wish to keep the stitch pattern, store it in the machine (“Saving Stitch Patterns in the Machine’s Memory” on page 171).



Chapter 5

Embroidery

BEFORE EMBROIDERING 182

Embroidery Step by Step	182
Attaching Embroidery Foot "W"	183
Attaching the Embroidery Unit	184
■ About the Embroidery Unit	184
■ Removing the Embroidery Unit	185

SELECTING PATTERNS..... 186

■ Copyright Information	186
■ Pattern Selection Screens	187
Selecting Embroidery Patterns/Brother "Exclusives"/Greek Alphabet Patterns/Floral Alphabet Patterns/Utility Embroidery Patterns.....	189
Selecting Alphabet Character Patterns.....	190
Selecting Frame Patterns.....	192
Selecting Patterns from Embroidery Cards.....	194
■ About Embroidery Card Reader (Sold Separately) and USB Card Writer Module*.....	194
■ About Embroidery Cards (Sold Separately).....	194
Selecting Patterns from USB Media/Computer	195

VIEWING THE SEWING SCREEN 196

■ Key Functions	197
-----------------------	-----

PREPARING THE FABRIC..... 198

Attaching Iron-on Stabilizers (Backing) to the Fabric.....	198
Hooping the Fabric in the Embroidery Frame	200
■ Types of Embroidery Frames	200
■ Inserting the Fabric	201
■ Using the Embroidery Sheet	202
Embroidering Small Fabrics or Fabric Edges.....	203
■ Embroidering Small Fabrics	203
■ Embroidering Edges or Corners	203
■ Embroidering Ribbons or Tape	203

ATTACHING THE EMBROIDERY FRAME..... 204

■ Removing the Embroidery Frame	205
---------------------------------------	-----

CONFIRMING THE PATTERN POSITION 206

Using the Built-In Camera to Align the Embroidering Position.....	206
Checking the Pattern Position	209
Previewing the Completed Pattern.....	210

SEWING AN EMBROIDERY PATTERN 212

Sewing Attractive Finishes	212
■ Embroidery Needle Plate Cover	213
Sewing Embroidery Patterns	213
Sewing Embroidery Patterns Which Use Appliqué.....	215

PRINT AND STITCH (COMBINING EMBROIDERY PATTERNS AND PRINTED DESIGNS) 217

Selecting a Pattern	218
■ Checking Only the Embroidery Pattern.....	218
Outputting the Background Image and Positioning Image.....	219
■ Using USB Media	219
■ Using a USB Cable	220
Printing the Background and Embroidery Position Sheet	221
Sewing Embroidery Patterns	222

ADJUSTMENTS DURING THE EMBROIDERY PROCESS 223

If the Bobbin Runs Out of Thread	223
If the Thread Breaks During Sewing.....	224
Restarting from the Beginning	225
Resuming Embroidery After Turning Off the Power	225

MAKING EMBROIDERY ADJUSTMENTS 227

Adjusting Thread Tension	227
■ Correct Thread Tension.....	227
■ Upper Thread is Too Tight	227
■ Upper Thread is Too Loose	228
Adjusting the Alternate Bobbin Case (with No Color on the Screw)	228
■ Correct Tension.....	228
■ Bobbin Thread is Too Loose	229
■ Bobbin Thread is Too Tight	229
Using the Automatic Thread Cutting Function (END COLOR TRIM).....	229
Using the Thread Trimming Function (JUMP STITCH TRIM)..	230
■ Selecting the Length of Jump Stitch Not to Trim	230
Adjusting the Embroidery Speed.....	231
Changing the Thread Color Display.....	231
Changing the Embroidery Frame Display	232

REVISING THE PATTERN..... 234

Changing the Pattern Position	234
Aligning the Pattern and the Needle.....	235
Changing the Size.....	236
Rotating the Pattern	237
Creating a Horizontal Mirror Image.....	238
Changing the Density	
(Alphabet Character and Frame Patterns Only).....	239
Changing the Colors of Alphabet Character Patterns	240
Embroidering Linked Characters	241
Uninterrupted Embroidering (Using a Single Color).....	243

USING THE MEMORY FUNCTION 244

Embroidery Data Precautions.....	244
■ Types of Embroidery Data that can be Used	244
■ Types of USB Devices/Media that can be Used	244
■ Computers and Operating Systems with the Following Specifications can be Used	245
■ Precautions on Using the Computer to Create and Save Data	245
■ Tajima (.dst) Embroidery Data	245
■ Trademarks	245
Saving Embroidery Patterns in the Machine's Memory.....	246
■ If the Memory is Full	247
Saving Embroidery Patterns to USB Media	249
Saving Embroidery Patterns in the Computer	250
Retrieving Patterns from the Machine's Memory	251
Recalling from USB Media	252
Recalling from the Computer	254

EMBROIDERY APPLICATIONS 256

Using a Frame Pattern to Make an Appliqué (1).....	256
Using a Frame Pattern to Make an Appliqué (2).....	257
Sewing Split Embroidery Patterns.....	259

BEFORE EMBROIDERING

Embroidery Step by Step

Follow the steps below to prepare the machine for embroidery.

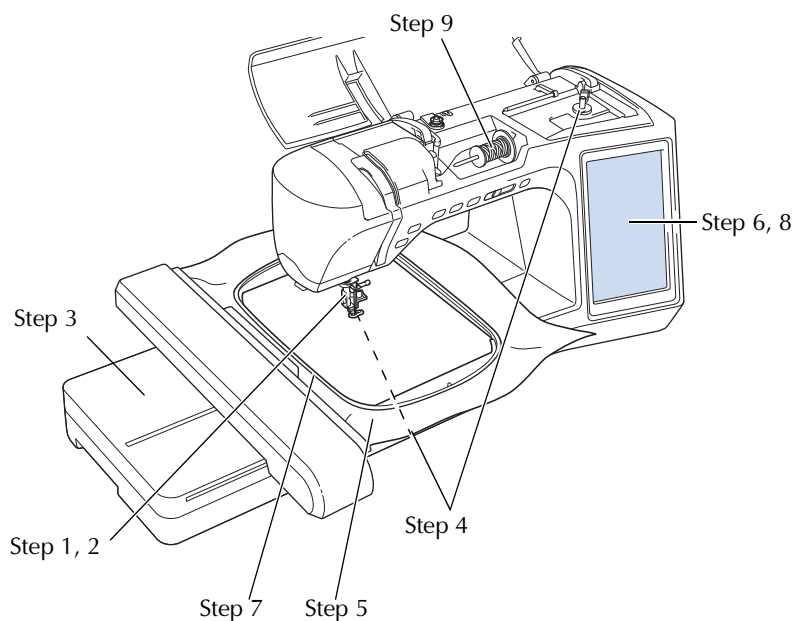



Step #	Aim	Action	Page
1	Presser foot attachment	Attach embroidery foot "W".	183
2	Checking the needle	Use needle 75/11 for embroidery. *	58
3	Embroidery unit attachment	Attach the embroidery unit.	184
4	Bobbin thread setup	For the bobbin thread, wind embroidery bobbin thread and set it in place.	37
5	Fabric preparation	Attach a stabilizer material to the fabric, and hoop it in the embroidery frame.	198
6	Pattern selection	Turn the main power to ON, and select an embroidery pattern.	186
7	Embroidery frame attachment	Attach the embroidery frame to the embroidery unit.	204
8	Checking the layout	Check and adjust the size and position of the embroidery.	206
9	Embroidery thread setup	Set up embroidery thread according to the pattern.	46

* It is recommended that a 90/14 needle should be used when embroidering on heavy weight fabrics or stabilizing products (for example; denim, puffy foam, etc.). Ball point needle (golden colored) 90/14 is not recommended for embroidery.

Attaching Embroidery Foot “W”

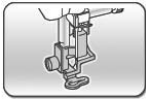
Press **?** → Operation Guide → Embroidery Basic Operation →



→  in this order to display a

video example of attaching embroidery foot “W” (see page 34). Follow the steps explained below to complete the operation.

⚠ CAUTION

- When attaching a presser foot, always press  on the screen. You may accidentally press the “Start/Stop” button and possibly cause injury.
- Be sure to use embroidery foot “W” when doing embroidery. Using another presser foot may cause the needle to strike the presser foot, causing the needle to bend or break and possibly cause injury.

- 1** Press the “Needle Position” button to raise the needle.

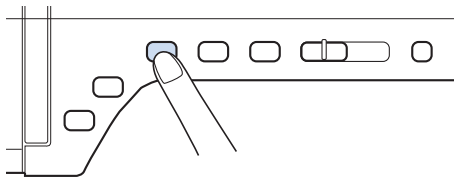

- 2** Press .

→ The entire screen becomes white, and all keys and operation buttons are locked.

- 3** Raise the presser foot lever.

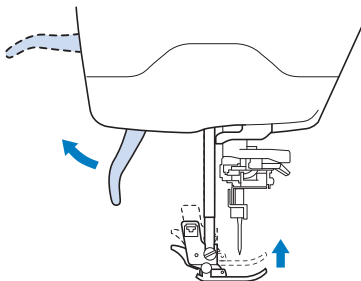

- 4** Push the black button on the presser foot holder and remove the presser foot.

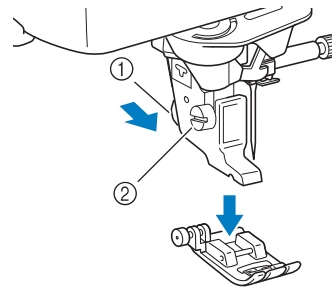

- ① Black button
② Presser foot holder
→ Remove the presser foot from the presser foot holder.

- 5** Use the included screwdriver to loosen the screw of the presser foot holder, then remove the presser foot holder.

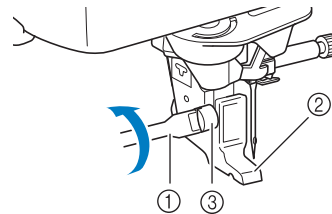

- ① Screwdriver
② Presser foot holder
③ Presser foot holder screw
→ Remove the presser foot holder.

- 6** Position embroidery foot “W” on the presser foot bar so that the arm of embroidery foot “W” is behind the needle holder and the wiper is behind the needle.

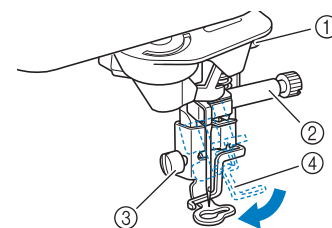

- ① Arm
② Needle holder
③ Presser foot holder screw
④ Wiper

5

Embroidery

- 7** Hold the embroidery foot in place with your right hand, and then use the included screwdriver to securely tighten the presser foot holder screw.

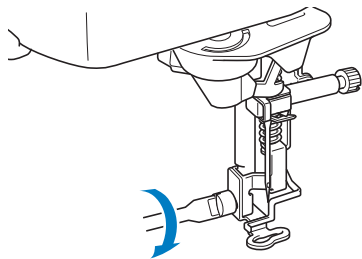

CAUTION

- Use the included screwdriver to firmly tighten the screw of the presser foot holder. If the screw is loose, the needle may strike the presser foot and possibly cause injury.

- 8** Press to unlock all keys and buttons.

→ All keys and operation buttons are unlocked, and the previous screen is displayed.

Attaching the Embroidery Unit

Press → → →

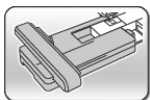

→ in this order to display a

video example of attaching the embroidery unit (see page 34). Follow the steps explained below to complete the operation.

About the Embroidery Unit

CAUTION

- Do not move the machine with the embroidery unit attached. The embroidery unit could fall off and cause injury.
- Keep your hands and foreign objects away from the embroidery carriage and frame when the machine is embroidering. Otherwise, injury may result.
- To avoid distorting your embroidery design, do not touch the embroidery carriage and frame when the machine is embroidering.

Note

- You can also sew utility/decorative stitches with the embroidery unit attached. Touch and . The feed dog will automatically raise for utility and decorative stitching.
- Be sure to turn off the power before installing the embroidery unit. Otherwise, the machine may be damaged.
- Do not touch the inner connector of the embroidery unit. The pins on the embroidery unit connection may be damaged.
- Do not apply strong force to the embroidery unit carriage or pick up the unit by the carriage. Otherwise, the embroidery unit may be damaged.
- Store the embroidery unit in the proper storage case.

- 1** Turn the main power to OFF, and remove the flat bed attachment.

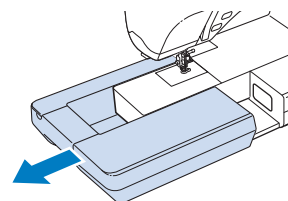

- 2** Insert the embroidery unit connection into the machine connection port. The spring hinge on the connection port cover will allow easy access to the port. Push lightly on the connection port cover until the unit clicks into place.

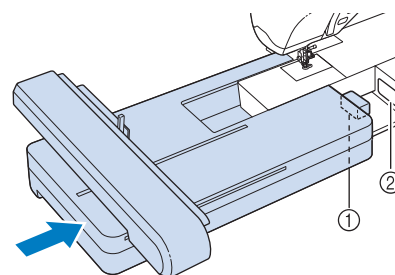

- ① Embroidery unit connection
- ② Machine connection port

Note

- Be sure there is no gap between the embroidery unit and the sewing machine. If there is a gap, the embroidery patterns will not embroider with the correct registration.
- Do not push on the carriage when installing the embroidery unit onto the machine. Moving the carriage may damage the embroidery unit.

3 Turn the main power to ON.

→ The following message will appear.

4 Press  **.**

→ The carriage will move to the initialization position.

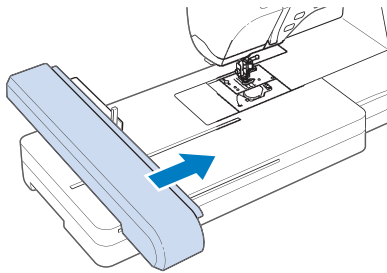
**■ Removing the Embroidery Unit****1 Press either**  **or**  **, then press**

→ The carriage will move to the removal position.

! CAUTION

- Always remove the embroidery frame before pressing . Otherwise, the frame may strike the embroidery foot, and possibly cause injury.
- The embroidery unit will not fit in the storage case if this step is not done.

2 Turn the main power to OFF.**Note**

- Be sure to turn off the machine before removing the embroidery unit, otherwise damage to the machine may result.

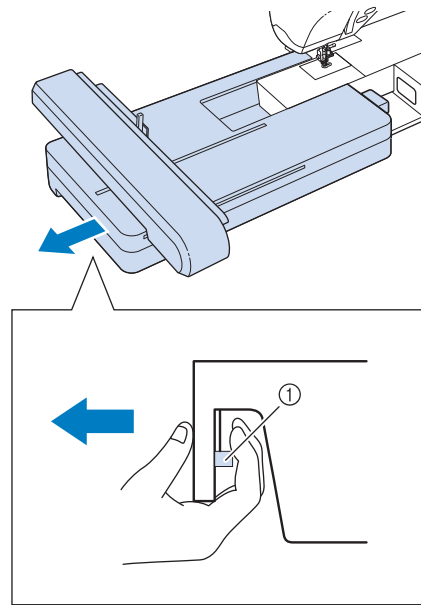
3 Hold down the release button, and pull the embroidery unit away from the machine.

① Release button

! CAUTION

- Do not carry the embroidery unit by holding the release button compartment.

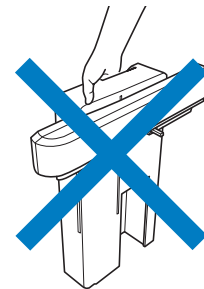
**5**

Embroidery

SELECTING PATTERNS

■ Copyright Information

The patterns stored in the sewing machine and embroidery cards are intended for private use only. Any public or commercial use of copyrighted patterns is an infringement of copyright law and is strictly prohibited.

There are many character and decorative embroidery patterns stored in the machine's memory (see the "QUICK REFERENCE GUIDE" for a full summary of patterns in the machine's memory). You can also use patterns from the embroidery cards (sold separately).

Once the machine has finished the initialization and the carriage has moved to the start position, the pattern type selection screen will display.

If another screen is displayed, press , then  to display the screen below.

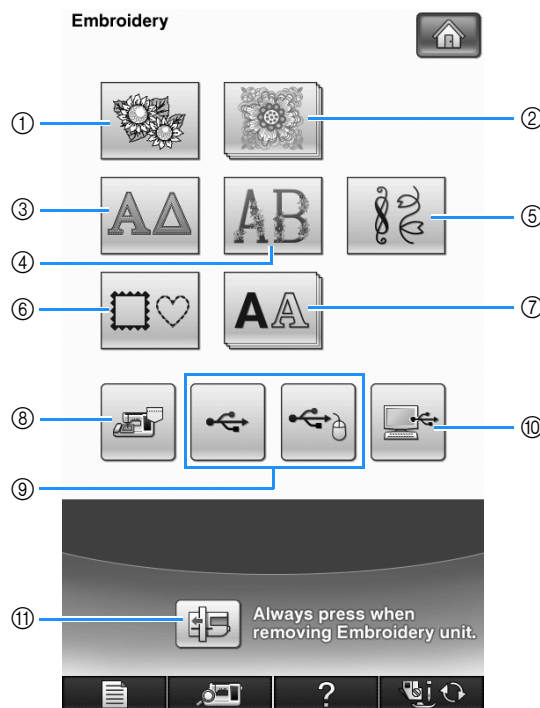

- ① Embroidery patterns
- ② Brother "Exclusives"
- ③ Greek alphabet patterns
- ④ Floral alphabet patterns
- ⑤ Utility embroidery patterns
- ⑥ Frame patterns
- ⑦ Alphabet characters
- ⑧ Patterns saved in the machine's memory (see page 251)
- ⑨ Patterns saved in USB media (see page 252)
- ⑩ Patterns saved on the computer (see page 254)
- ⑪ Press this key to position the embroidery unit for storage.

Memo

- A key that appears stacked, such as



and , indicates that there are sub-categories, which must be selected before a pattern selection screen appears.

■ Pattern Selection Screens

There are 7 categories of patterns in this machine. If a page number such as $\frac{1}{2}$ appears, there is more than one pattern selection screen for that category.



Embroidery patterns



Greek alphabet patterns

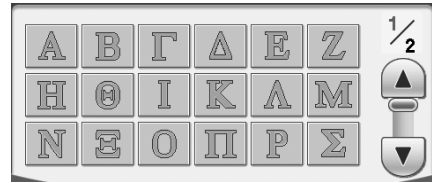

Floral alphabet patterns

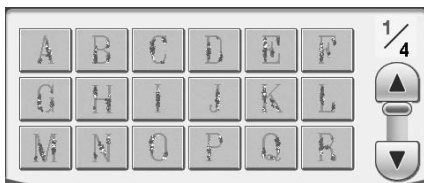

Utility embroidery patterns

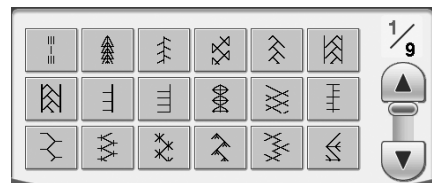

Frame patterns

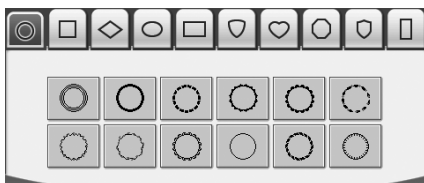

Alphabet characters

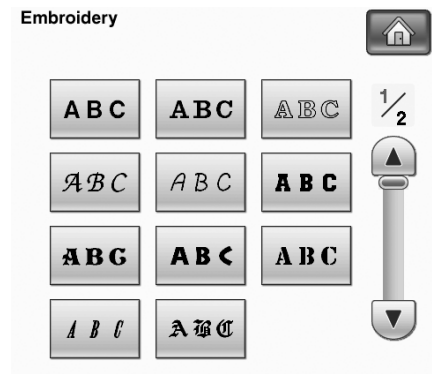



Brother "Exclusives"

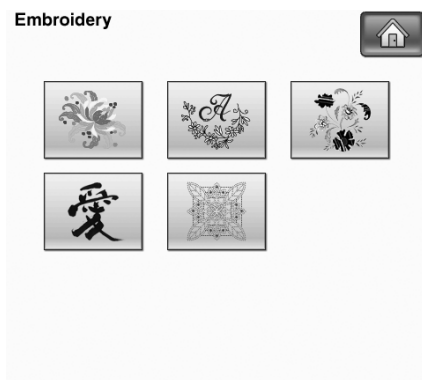

Vintage designs

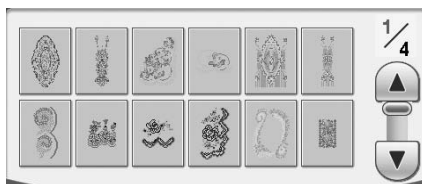

Monogram designs

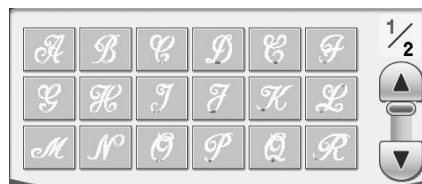

New European designs



Japanese designs



Quilt designs

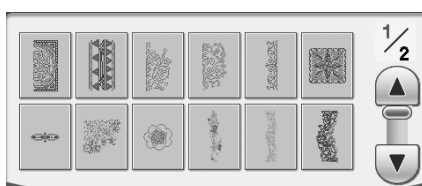

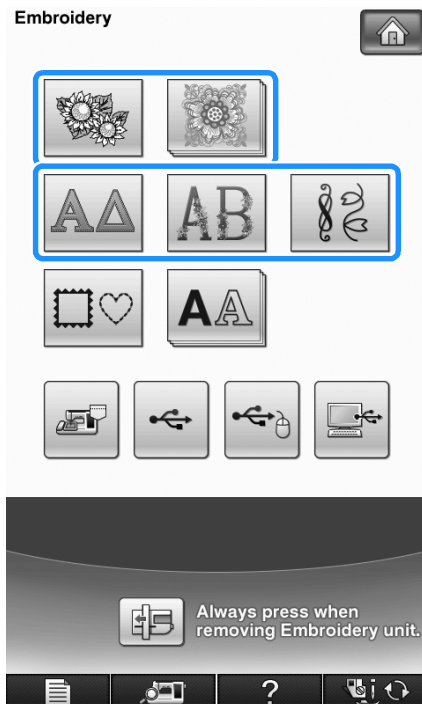

Selecting Embroidery Patterns/ Brother "Exclusives"/Greek Alphabet Patterns/Floral Alphabet Patterns/Utility Embroidery Patterns

- 1 Touch the key of the category of the pattern you want to embroider.



- 2 Press the key of the pattern you want to embroider.



- * Press  to view the next page.
 - * Press  to view the previous page.
- The selected pattern is displayed.

- 3 Press  to create a mirror image of the pattern as needed.

- * If a mistake has been made when selecting the pattern, press the key of the pattern you want to embroider and the new selection appears.

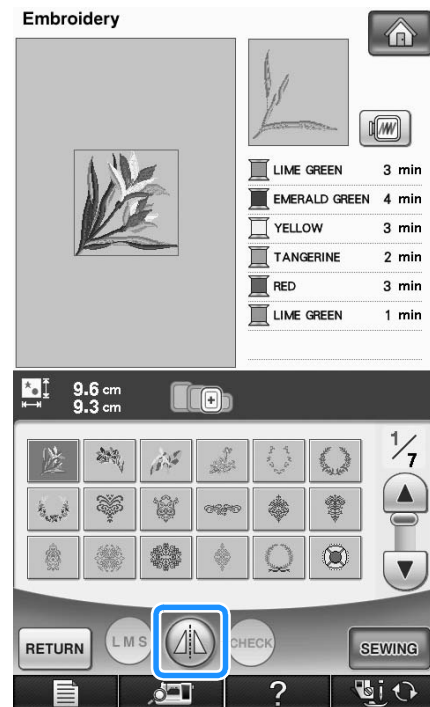

- 4 Press .

→ The sewing screen is displayed.

5 Proceed to “VIEWING THE SEWING SCREEN” on page 196 to embroider the pattern.

* To return to the previous screen to select another pattern, press **RETURN**.

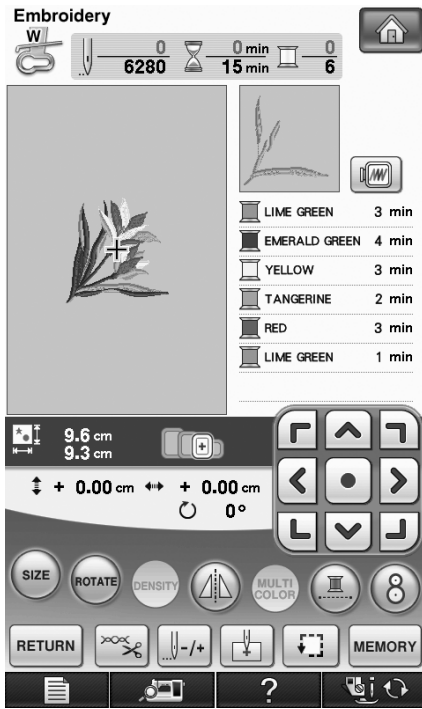

2 Press the key of the font you want to embroider.

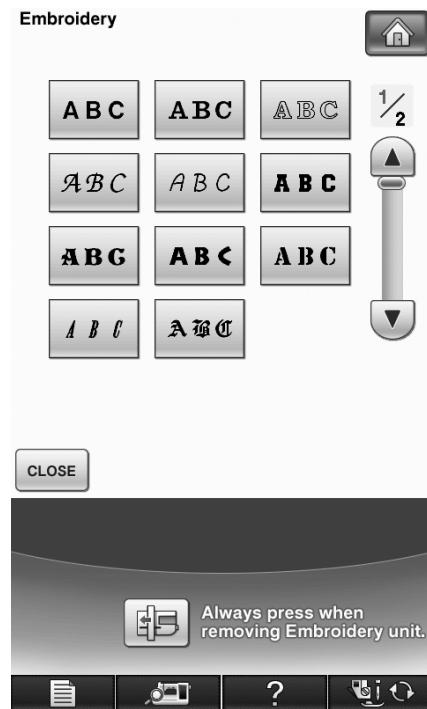

3 Press to change the selection screens.

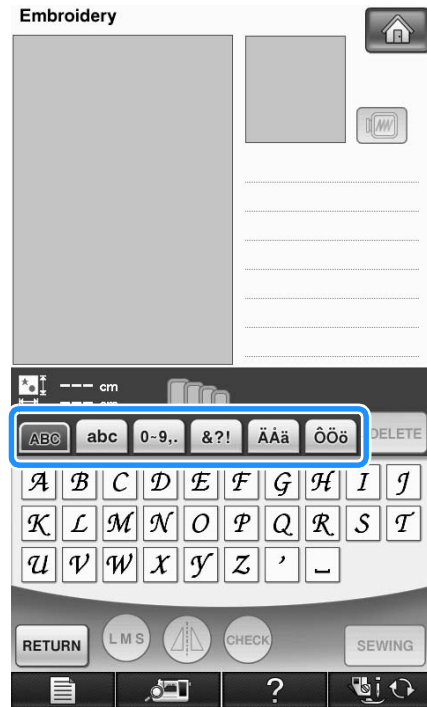

Selecting Alphabet Character Patterns

Example: Entering “Blue Sky”.

1 Press **AA**.



Memo

- If you continue adding characters after changing the size, the new characters will be entered in the new size.
- You cannot change the size of the entered characters after combining character stitch patterns.

4 Press **ABC** and then enter "B".

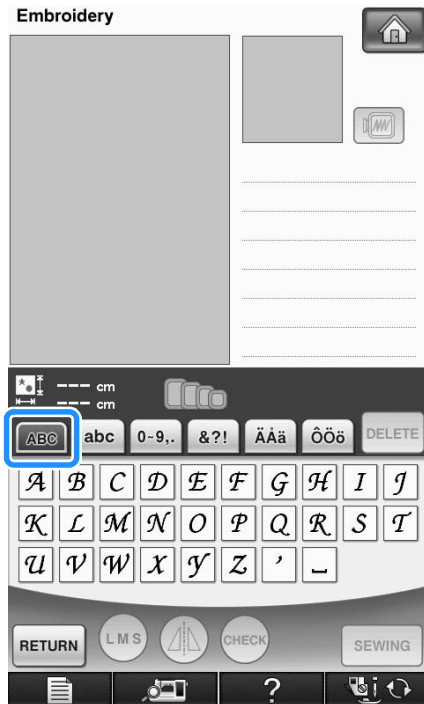

- * If you want to change the size of a character, select the character and then press **LMS** to change the size. The size changes each time you press the key, from large to medium to small.
- * If you make a mistake, press **DELETE** to erase the mistake.
- * If the pattern is too small to see clearly, you can use the **CHECK** key to check it.

5 Press **abc** and enter "lue".

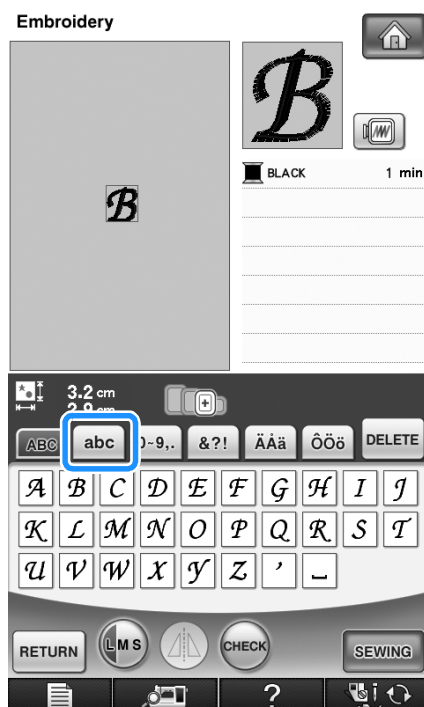

6 Press to enter a space.



7 Press **ABC** again and enter "S".



5

Embroidery

8 Press **abc** and then enter “ky”.

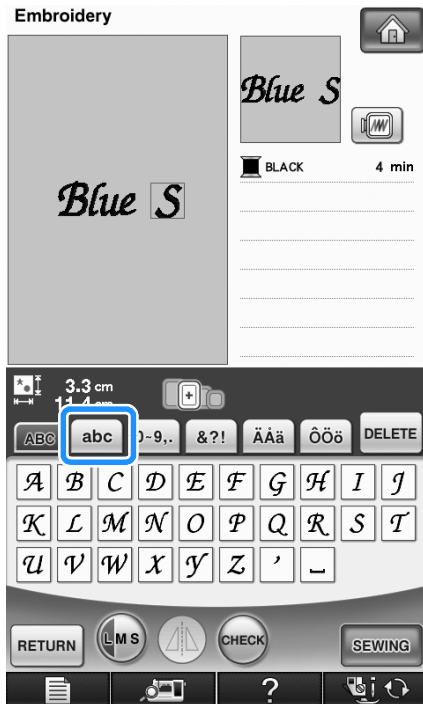

9 Press **SEWING**.



→ The sewing screen is displayed.

10 Proceed to “VIEWING THE SEWING SCREEN” on page 196 to embroider the pattern.

* To return to the previous screen to select another pattern, press **RETURN**.

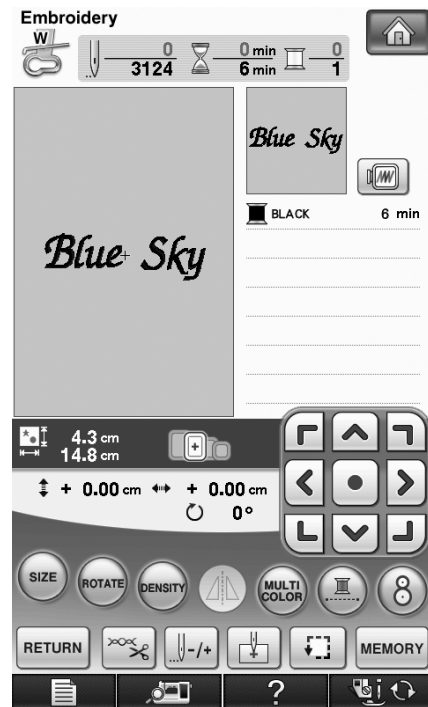

Selecting Frame Patterns

1 Press .

- 2** Press the key of the frame shape you want to embroider in the top part of the screen.

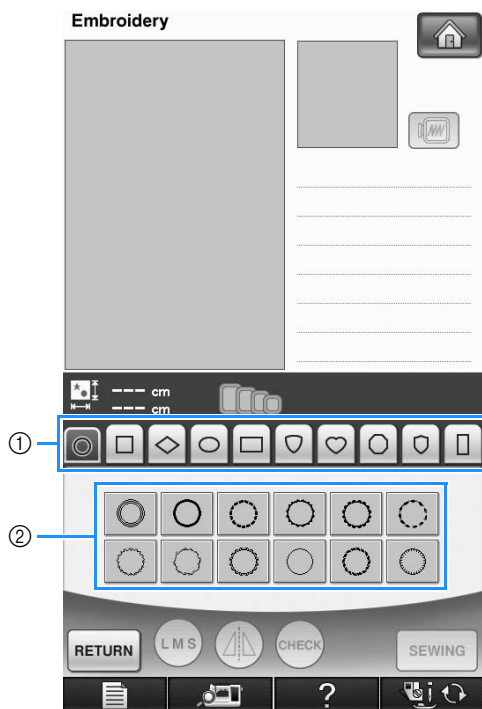

① Frame shapes

② Frame patterns

→ Various frame patterns are displayed at the bottom part of the screen.

- 3** Press the key of the frame pattern you want to embroider.

* If you make a mistake selecting the pattern, press the key of the pattern you want to embroider.

→ The selected pattern is displayed on the screen.

- 4** Press **SEWING**.

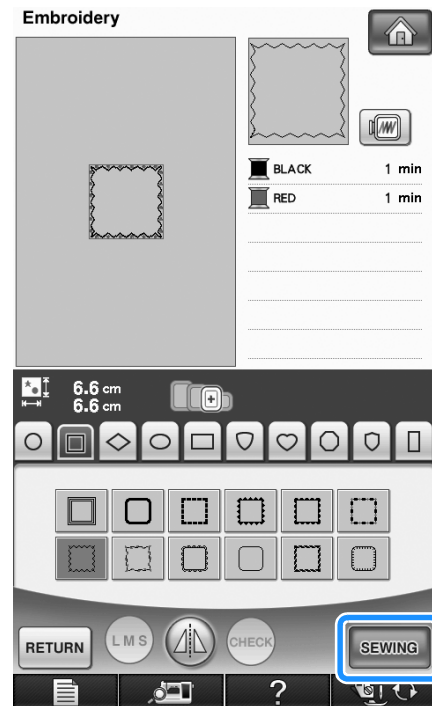

→ The sewing screen is displayed.

- 5** Proceed to “VIEWING THE SEWING SCREEN” on page 196 to embroider the pattern.

* To return to the previous screen to select another pattern, press **RETURN**.

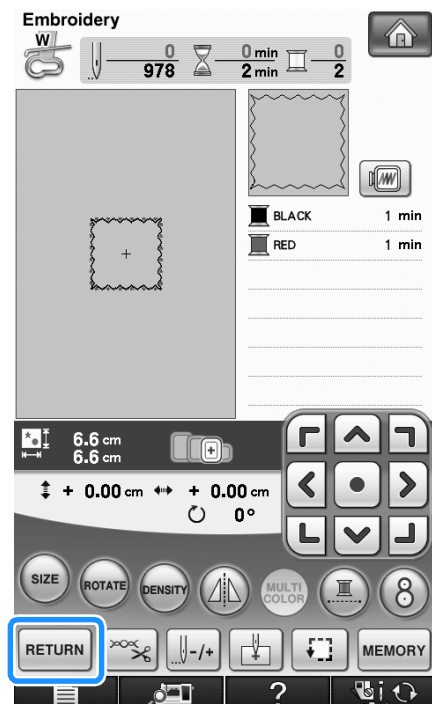

Selecting Patterns from Embroidery Cards

About Embroidery Card Reader (Sold Separately) and USB Card Writer Module*

- Use only an embroidery card Reader designed for this machine. Using an unauthorized embroidery card Reader may cause your machine to operate incorrectly.
- * If you have purchased the PE-DESIGN Ver5 or later, PE-DESIGN Lite or PED-BASIC, you can plug the included USB card writer module into the machine as an embroidery card reader, and recall patterns.



Note

- Embroidery patterns cannot be saved from the machine to an embroidery card inserted into a connected USB card writer module*.

About Embroidery Cards (Sold Separately)

- Use only embroidery cards manufactured for this machine. Using unauthorized cards may cause your machine to operate incorrectly.
- Embroidery cards sold in foreign countries cannot be used with this machine.
- Store embroidery cards in the hard case.

1 Plug the optional embroidery card Reader/USB card writer module* into the primary (top) USB port on the machine.

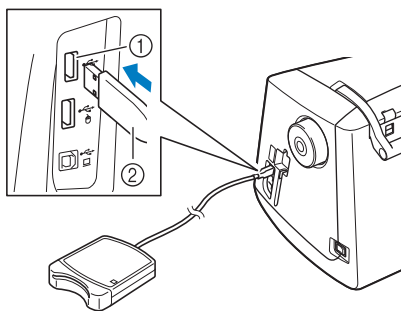

- ① Primary (top) USB port
- ② Embroidery card Reader/USB card writer module*

2 Insert the card completely into the card Reader/USB card writer module*.

- * Insert the embroidery card so that the end with a printed arrow is facing up.

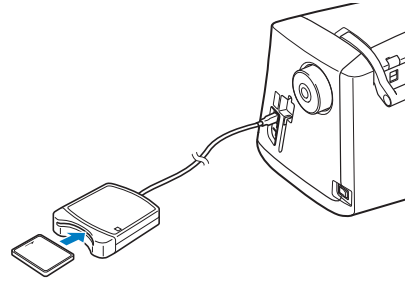

Note

- Two embroidery USB card Readers/USB card writer module* cannot be used with this machine at the same time. If two embroidery USB card Readers/USB card writer module* are inserted, only the embroidery USB card Reader/USB card writer module* inserted first is detected.



Memo

- You can also plug the embroidery card Reader/USB card writer module* into the center port of the machine.

3 Press the key of the USB port that the embroidery card Reader/USB card writer module* is plugged into.

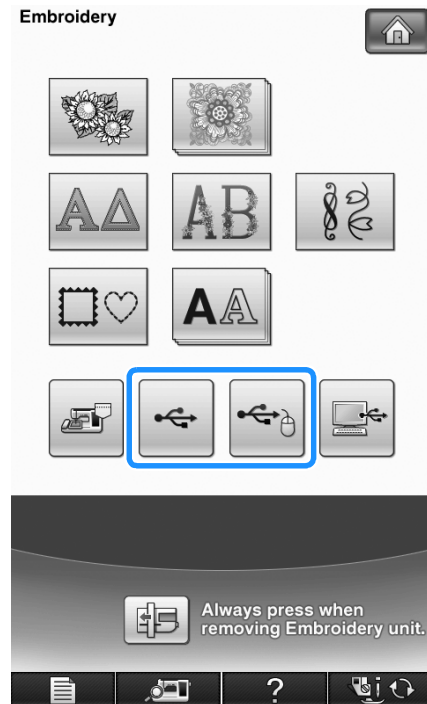

- The patterns on the embroidery card are displayed on the selection screen.

4 Follow the steps on page 189 to select a pattern.

Selecting Patterns from USB Media/Computer

To recall patterns from the computer or USB media, see pages 252 through 255.

VIEWING THE SEWING SCREEN

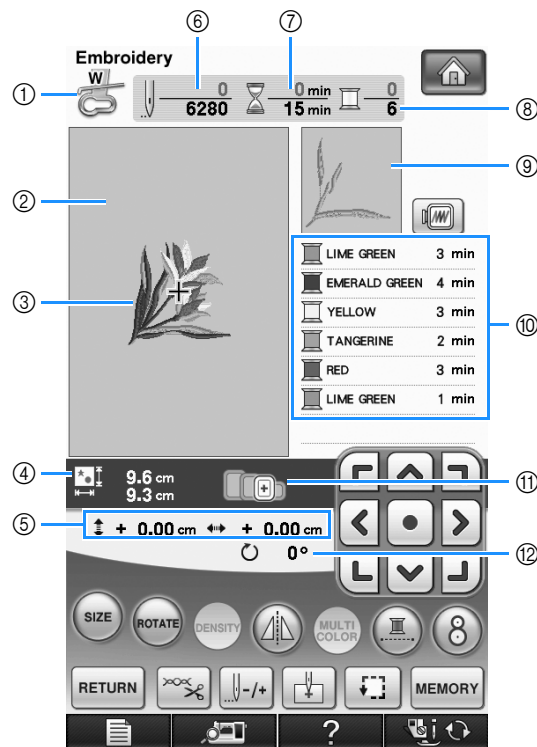

- ① Shows the presser foot code.
Attach embroidery foot "W" for all embroidery projects. When the foot presser symbol is displayed on the screen, you are able to sew.
- ② Shows the boundary for embroidering with the extra large frame (30 cm × 20 cm (approx. 12 inches × 8 inches)).
- ③ Shows a preview of the selected pattern.
- ④ Shows the size of the selected pattern.
- ⑤ Shows how far the sewing position is from the center (when you move the sewing position).
- ⑥ Shows how many stitches are in the selected pattern and how many stitches have been sewn so far.
- ⑦ Shows the time necessary to sew the pattern, and the time already spent sewing the pattern (not including time for changing and automatically trimming the thread).
- ⑧ Shows the number of colors in the selected pattern, and the number of the color currently being sewn.
- ⑨ Shows the part of the embroidery that will be sewn with the first thread color.
- ⑩ Shows the order for thread color changes and the embroidering time for each thread color.
- * The displayed time is the approximate time that will be required. The actual embroidering time may be longer than the displayed time, depending on the embroidery frame that is used. In addition, the amount of time required to change thread colors is not included.
- ⑪ Shows the embroidery frames that can be used for the selected pattern. Be sure to use the proper frame (see page 200).
- ⑫ Shows the degree of rotation of the pattern.



Note

- There is an explanation of additional key functions on the next page.

■ Key Functions

Using these keys, you can change the size of the pattern, rotate the pattern, etc.

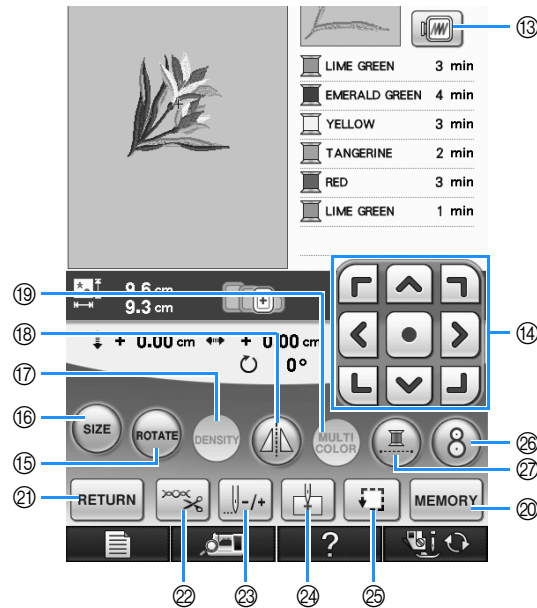

No.	Display	Key Name	Explanation	Page
13		Image key	Press this key for a preview of the sewn image.	210
14		Arrow keys (Center key)	Press an arrow key to move the pattern in the direction shown by the arrow. (Press the Center key to return the pattern to the center of the embroidery area.)	234
15		Rotate key	Press this key to rotate the pattern. You can rotate a pattern one degree, 10 degrees or 90 degrees at a time.	237
16		Size key	Press this key to change the size of the pattern.	236
17		Density key	Press this key to change the density of alphabet character or frame patterns.	239
18		Horizontal mirror image key	Press this key to create a horizontal mirror image of the pattern.	238
19		Multi color key	Press this key to change the color of each letter when sewing alphabet character patterns.	240
20		Memory key	Press this key to save a pattern in the machine's memory, USB media or a computer.	246-250
21		Return key	Press this key to return to the pattern type selection screen.	—
22		Cut/Tension key	Press this key to specify automatic thread cutting, thread trimming or the thread tension. For embroidery, these functions are set automatically.	229-230
23		Forward/Back key	Press this key to move the needle forward or back in the pattern; useful if the thread breaks while sewing or if you want to start again from the beginning.	224-226
24		Starting point key	Press this key to move the needle start position to align the needle with the pattern position.	235
25		Trial key	Press this key to check the position of the pattern. The embroidery frame moves to the desired position so you can check that there is enough space to sew the pattern.	209
26		Embroidery positioning key	Press this key to align the embroidering position using the built-in camera.	206
27		Uninterrupted embroidery key	Press this key to embroider the selected pattern with a single color.	243



Note

- Some operations or functions are not available for certain patterns. If the key display is light gray, you cannot use that function or operation with the selected pattern.



PREPARING THE FABRIC

⚠ CAUTION

- Use fabrics with a thickness of less than 3 mm (approx. 1/8 inch). Using fabrics thicker than 3 mm (approx. 1/8 inch) may cause the needle to break.
- When using layers with thicker batting etc., you can sew more attractive embroidery by adjusting the embroidery presser foot height in the embroidery settings screen (see below).
- In the case of thick terry cloth towels we recommend that you place a piece of water soluble stabilizer on the top surface of the towel. This will help to reduce the nap of the toweling and result in more attractive embroidery.



Note

- Press , and select page 6/7 to use  and  in the Embroidery Foot Height display in the embroidery settings screen. Adjust the presser foot height for thick or puffy fabrics.

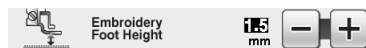

- To increase the space between the presser foot and the needle plate, set the embroidery foot height to a larger number, 1.5mm setting is used for most embroidery.

Attaching Iron-on Stabilizers (Backing) to the Fabric

For best results in your embroidery projects, always use stabilizer material for embroidery. Follow the package instructions for the stabilizer being used.

Press  →  →  →

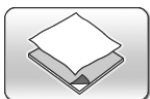

→  in this order to display a

video example of attaching iron-on stabilizers (backing) to the fabric (see page 34). Follow the steps explained below to complete the operation.

When using fabrics that cannot be ironed (such as towel or fabrics that have loops which expand when ironed) or in places where ironing is difficult, position the stabilizer material under the fabric without fusing it, then position the fabric and stabilizer in the embroidery frame, or check with your authorized dealer for the correct stabilizer to use.

⚠ CAUTION

- Always use a stabilizer material for embroidery when sewing stretch fabrics, lightweight fabrics, fabrics with a coarse weave, or fabrics which cause pattern shrinkage. Otherwise, the needle may break and cause injury. Not using a stabilizer material may result in a poor finish to your project.

- 1 Use a piece of stabilizer which is larger than the embroidery frame being used.

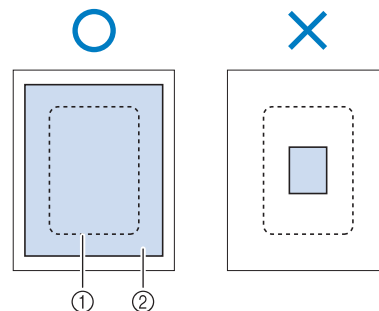

- ① Size of the embroidery frame
- ② Iron-on stabilizer (backing)

2 Iron the iron-on stabilizer material to the wrong side of the fabric.

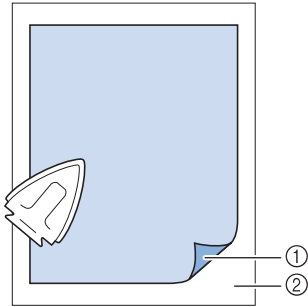

- ① Fusible side of stabilizer
- ② Fabric (wrong side)





Memo

- When embroidering on thin fabrics such as organdy or lawn, or on napped fabrics such as towel or corduroy, use water soluble stabilizer (sold separately) for best results. The water soluble stabilizer material will dissolve completely in water, giving the project a more attractive finish.

Hooping the Fabric in the Embroidery Frame

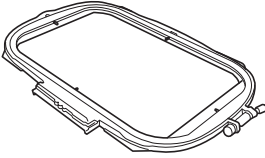
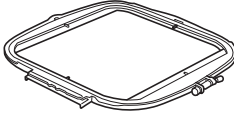
Types of Embroidery Frames

Extra Large	Quilt	Medium	Small
			
Embroidery field 30 cm × 20 cm (approx. 12 inches × 8 inches)	Embroidery field 20 cm × 20 cm (approx. 8 inches × 8 inches)	Embroidery field 10 cm × 10 cm (approx. 4 inches × 4 inches)	Embroidery field 2 cm × 6 cm (approx. 1 inch × 2-1/2 inches)
Use when embroidering connected or combined characters or patterns, or when embroidering large patterns.	Use when embroidering patterns between 10 cm × 10 cm (approx. 4 inches × 4 inches) and 20 cm × 20 cm (approx. 8 inches × 8 inches).	Use when embroidering patterns under 10 cm × 10 cm (approx. 4 inches × 4 inches).	Use for embroidering names or very small patterns.

Other optional embroidery frame can be used. When choosing frames that do not appear on the screen, be sure to check the design size of the embroidery field of the optional frame. Check with your authorized dealer for frame compatibility.

Select a frame that matches the pattern size. Included frame options are displayed on the LCD.

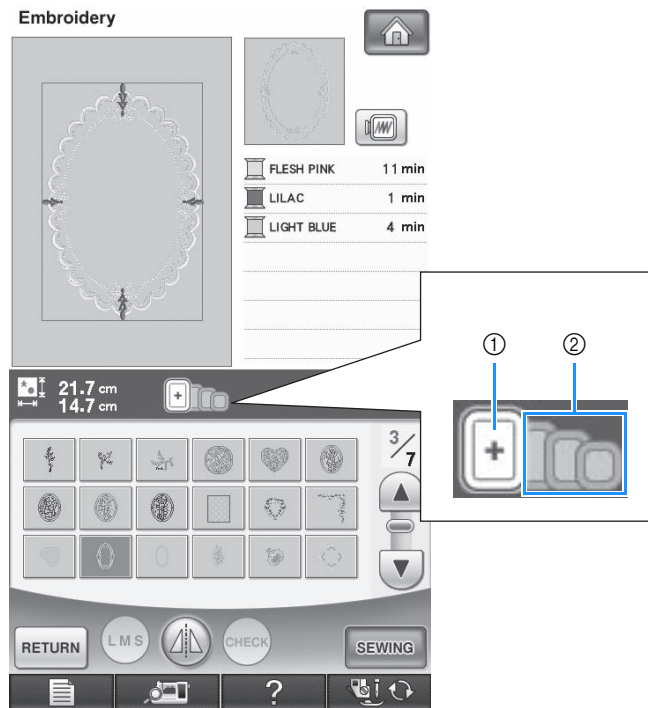

- ① Highlighted: Can be used
- ② Shaded: Cannot be used

CAUTION

- If you use a frame that is too small, the presser foot may strike the frame during sewing and cause injury.

■ Inserting the Fabric

Press **?** → Operation Guide → Embroidery Basic Operation →



in this order to display a video example of hopping the fabric in the embroidery frame (see page 34). Follow the steps explained below to complete the operation.



Note

- If the fabric is not securely held in the embroidery frame, the embroidery design will sew out poorly. Insert the fabric on a level surface, and gently stretch the fabric taut in the frame. Follow the steps below to insert the fabric correctly.

1 Lift-up and loosen the frame adjustment screw and remove the inner frame.

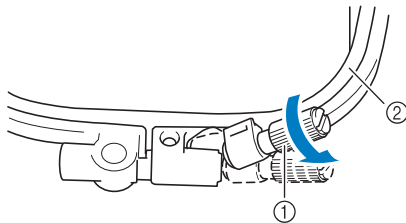

- ① Frame adjustment screw
- ② Inner frame

2 Lay the fabric right side up on top of the outer frame.

Re-insert the inner frame making sure to align the inner frame's \triangle with the outer frame's ∇ .

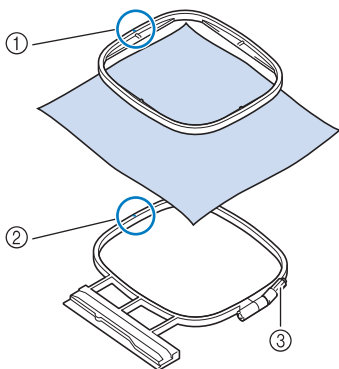

- ① Inner frame's \triangle
- ② Outer frame's ∇
- ③ Frame adjustment screw

3 Slightly tighten the frame adjustment screw, and then remove the slack in the fabric by pulling on the edges and corners. Do not loosen the screw.

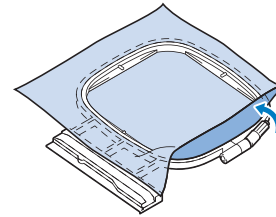

4 Gently stretch the fabric taut, and tighten the frame adjustment screw to keep the fabric from loosening after stretching.

- * After stretching the fabric, make sure the fabric is taut.

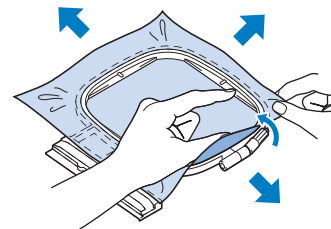

- * Make sure the inside and outside frames are even before you start embroidering.

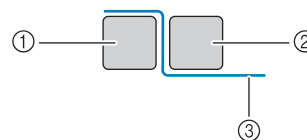

- ① Outer frame
- ② Inner frame
- ③ Fabric

Memo

- Stretch the fabric from all four corners and all four edges. While stretching the fabric, tighten the frame adjustment screw.

5 Return the frame adjustment screw to its initial position.

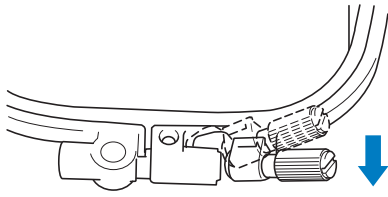

Memo

- You can use the included screw driver when you loosen or tighten the frame adjustment screw.

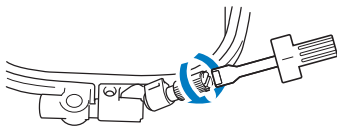

Using the Embroidery Sheet

When you want to embroider the pattern in a particular place, use the embroidery sheet with the frame.

1 With a chalk pencil, mark the area of the fabric you want to embroider.

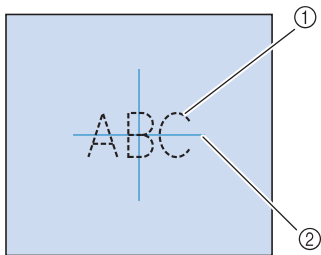

- ① Embroidery pattern
- ② Mark

2 Place the embroidery sheet on the inner frame. Align the guide lines on the embroidery sheet with the mark you made on the fabric.

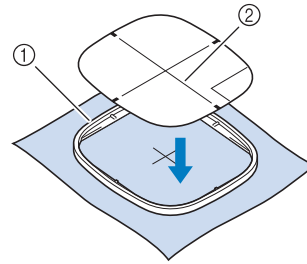

- ① Inner frame
- ② Guide line

3 Gently stretch the fabric so there are no folds or wrinkles, and press the inner frame into the outer frame.

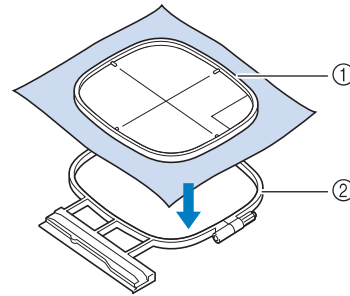

- ① Inner frame
- ② Outer frame

4 Remove the embroidery sheet.

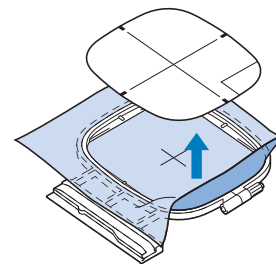

Embroidering Small Fabrics or Fabric Edges

Use an embroidery stabilizer to provide extra support. After embroidering, remove the stabilizer carefully. Attach the stabilizer as shown in the following examples. We recommend using a stabilizer for embroidery.

Embroidering Small Fabrics

Use a temporary spray adhesive to adhere the small piece of fabric to the larger piece in the frame. If you do not wish to use a temporary spray adhesive, attach the stabilizer with a basting stitch.

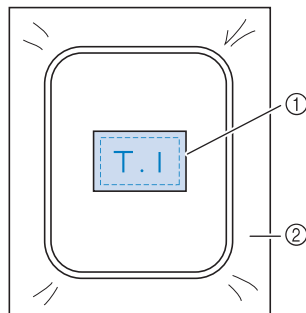

- ① Fabric
- ② Stabilizer

Embroidering Edges or Corners

Use a temporary spray adhesive to adhere the small piece of fabric to the larger piece in the frame. If you do not wish to use a temporary spray adhesive, attach the stabilizer with a basting stitch.

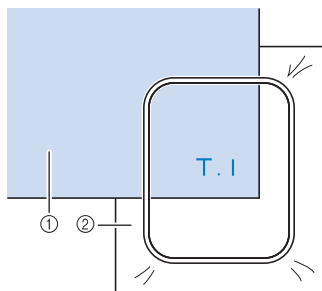

- ① Fabric
- ② Stabilizer

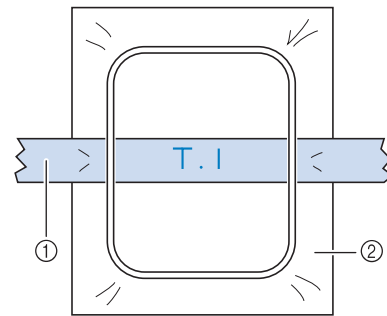

Embroidering Ribbons or Tape

Secure with double-sided tape or a temporary spray adhesive.

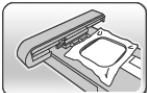

- ① Ribbon or tape
- ② Stabilizer

ATTACHING THE EMBROIDERY FRAME

Press **?** → **Operation Guide** → **Embroidery Basic Operation** →  →  in this order to display a video

example of attaching the embroidery frame (see page 34). Follow the steps explained below to complete the operation.

Note
 • Wind and insert the bobbin before attaching the embroidery frame.

1 Press the “Presser Foot Lifter” button to raise the presser foot.

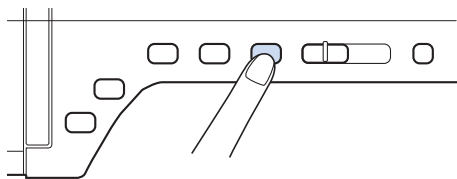

2 Align the embroidery frame guide with the right edge of the embroidery frame holder.

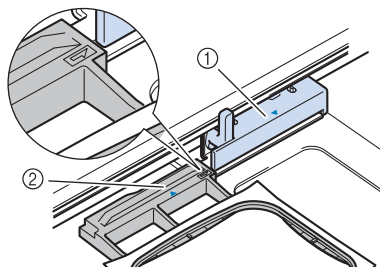

- ① Embroidery frame holder
- ② Embroidery frame guide

3 Slide the embroidery frame into the holder, making sure to align the embroidery frame's \triangle with the holder's ∇ .

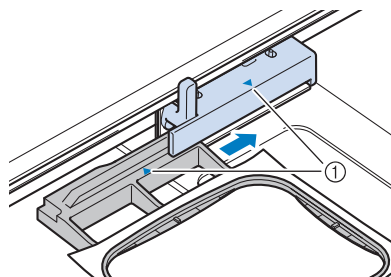

- ① Arrow mark

4 Lower the frame-securing lever to be level with the frame to secure the embroidery frame in the embroidery frame holder.

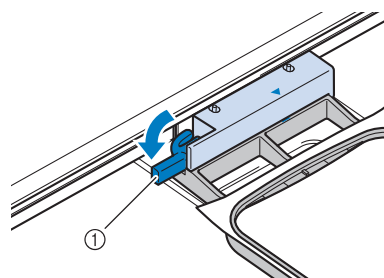

- ① Frame-securing lever

CAUTION

- If the frame-securing lever is not lowered, the following message appears. You cannot start sewing until you lower the frame-securing lever.



 Make sure embroidery frame is moved as far back as possible. LOCK DOWN THE FRAME-SECURING LEVER.

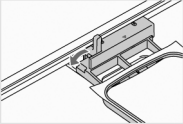

CLOSE

■ Removing the Embroidery Frame

- 1 Raise the frame-securing lever.

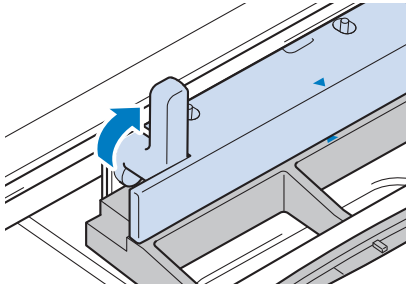

- 2 Pull the embroidery frame toward you.

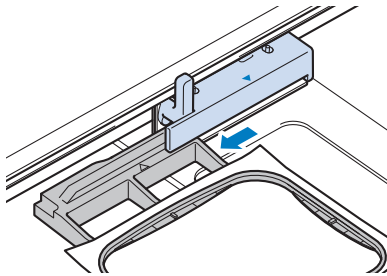

CONFIRMING THE PATTERN POSITION

The pattern is normally positioned in the center of the embroidery frame. If the pattern needs to be repositioned for better placement on the garment, you can check the layout before starting embroidery.

Using the Built-In Camera to Align the Embroidering Position

The embroidering position can easily be aligned using the machine's built-in camera and the included embroidery positioning sticker.

Note

- When embroidery frame (small) is installed, the built-in camera cannot be used to align the embroidering position. Install embroidery frame (medium) or a larger embroidery frame.

- 1** Affix the embroidery positioning sticker to the location in the fabric to be embroidered. Place the embroidery positioning sticker so that the center of the larger circle is at the center of the embroidery pattern.

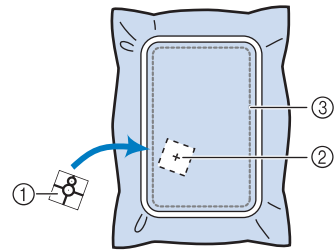

- ① Embroidery positioning sticker
- ② Center of the embroidery pattern
- ③ Embroidery field

Note

- When inserting the fabric in the embroidery frame, check that the embroidery pattern fits within the embroidery field for the frame that is used.

- ① Embroidery field
- ② Embroidery pattern
- ③ Embroidery positioning sticker

- Depending on the type of fabric that is used, a part of the embroidery positioning sticker may remain attached when it is peeled off. Before using the embroidery positioning sticker, check that it can be cleanly removed from a scrap piece of the fabric to be used.

- 2 After selecting the pattern, press **SEWING**, and then press **8**.

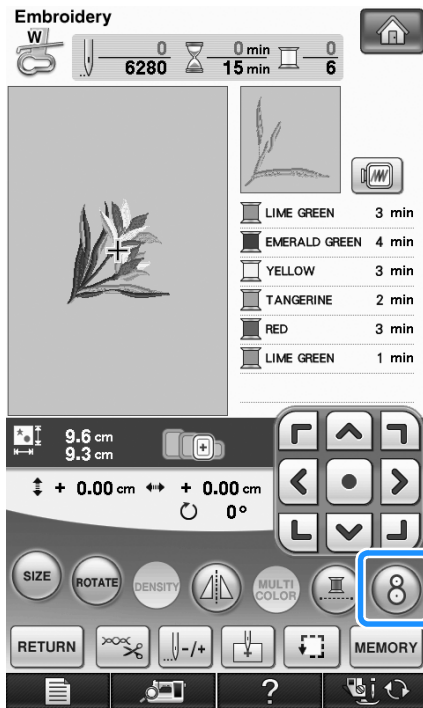

→ A window appears so that the area containing the embroidery positioning sticker can be selected.

- 3 From the areas shown in the window, select the area containing the embroidery positioning sticker.

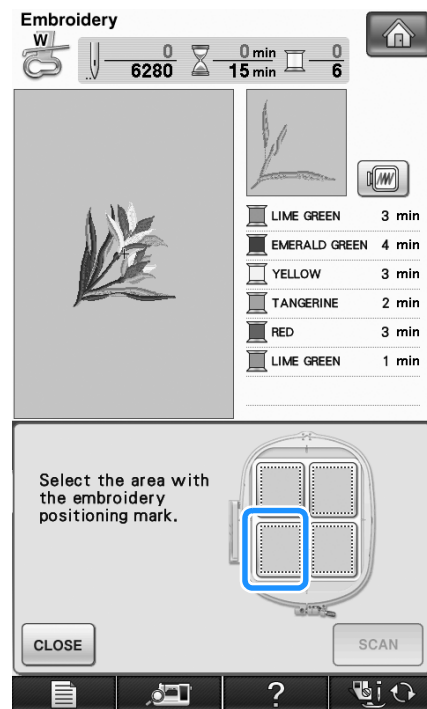
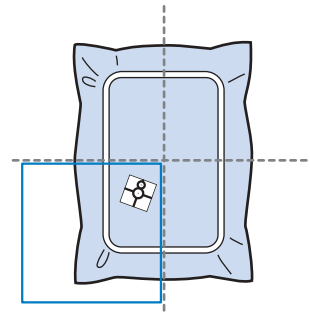

- Note**
- If the embroidery positioning sticker is placed in the center of embroidery frame, select any of the four areas.
 - If the embroidery positioning sticker overlaps two areas, select either of the two areas.

4 Press **SCAN**.

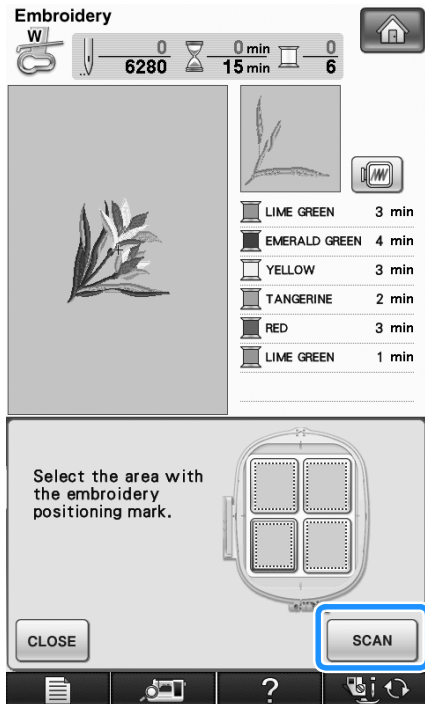

Note

- Attach embroidery foot “W” before pressing **SCAN**. The embroidery foot “W” lowers and check the fabric thickness, to help the built-in camera recognize the embroidery positioning sticker.

5 Following message appears. Press **OK**.

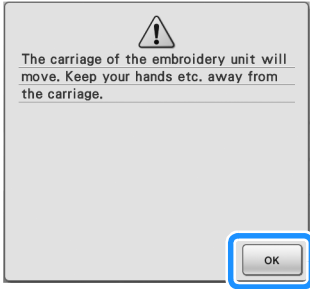

→ The built-in camera automatically searches for the embroidery positioning sticker, and then the carriage is moved so that the center of the embroidery pattern is aligned with the center of the embroidery positioning sticker. Regardless of the setting selected in the machine settings screen, the brightness of the light changes to “5” while the built-in camera searches for the embroidery positioning sticker.

Note

- If the following warning message appears, touch **CLOSE** and reposition the embroidery positioning sticker so the pattern is within the embroidery field, and then press **SCAN** again.

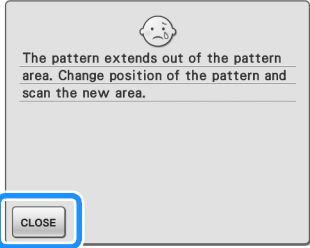

6 A reminder message appears. Remove the embroidery positioning sticker from the fabric, and press **CLOSE**.

* To remove the embroidery positioning sticker more easily, press  so that the embroidery frame moves slightly forward and away from under the needle. After the embroidery positioning sticker is removed, press **CLOSE**.

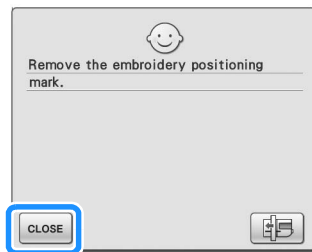
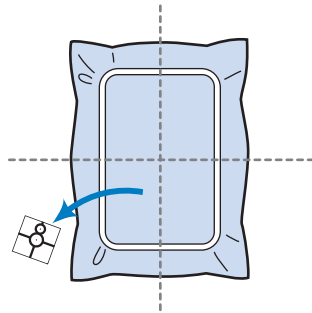

7 Press the "Start/Stop" button to begin embroidering.



Note

- After the included embroidery positioning stickers are used up, optional stickers are available. For details, refer to "Options" on page 8.

Checking the Pattern Position

The embroidery frame moves and shows the pattern position. Watch the frame closely to make sure the pattern will be sewn in the right place.

1 Press .

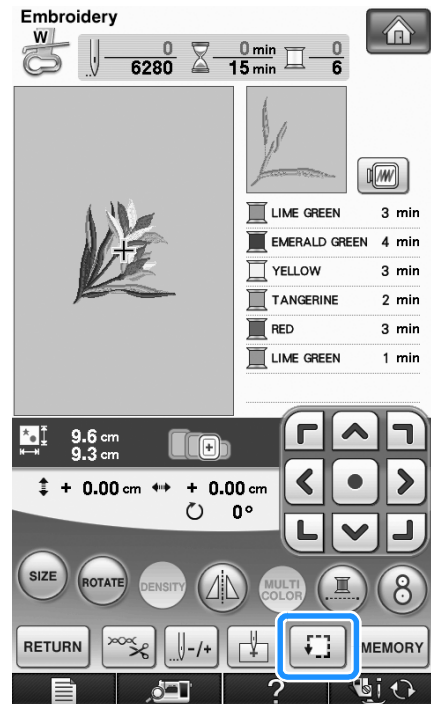

→ The following screen is displayed.

2 From , press the key for the position that you want to check.

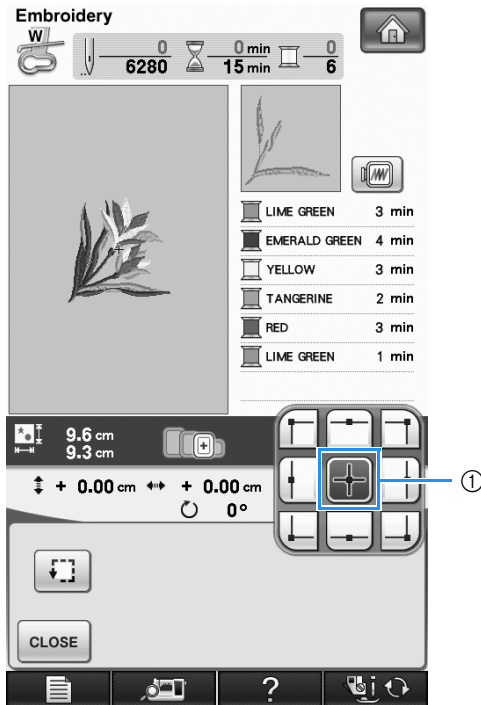

- ① Selected position
- The needle will move to the selected position on the pattern.

Memo

- To see the entire embroidering area, press . The embroidery frame moves and shows the embroidery area.

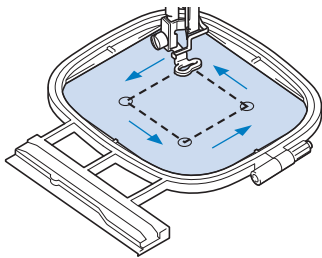

CAUTION

- Make sure the needle is up when the embroidery frame is moving. If the needle is down, it could break and result in injury.

3 Press .

Previewing the Completed Pattern

1 Press .

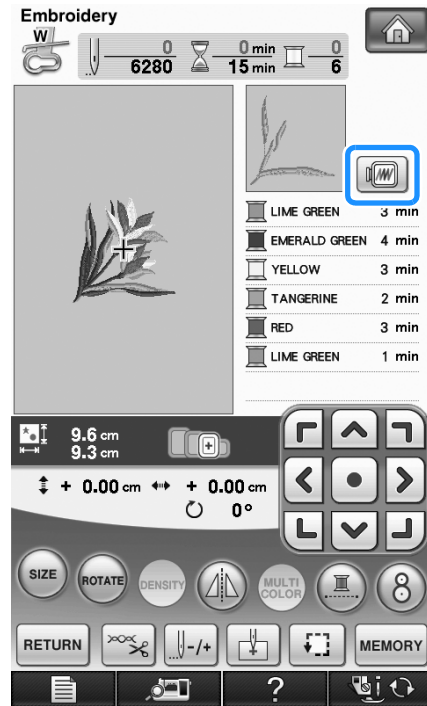

- An image of the pattern as it will be embroidered appears.

2 Press  to select the frame used in the preview.

- * Frames displayed in light gray cannot be selected.
- * Press  to enlarge the image of the pattern.
- * The pattern can be sewn as it appears in the following display.



Memo

- You can begin sewing from this screen by pressing the "Start/Stop" button.

3 Press  to return to the original screen.

SEWING AN EMBROIDERY PATTERN

Sewing Attractive Finishes

There are many factors that go into sewing beautiful embroidery. Using the appropriate stabilizer (see page 198) and hooping the fabric in the frame (see page 200) are two important factors mentioned earlier. Another important point is the appropriateness of the needle and thread being used. See the explanation of threads below. Included with this machine are two bobbin cases. Follow the explanation below.

Thread	Upper thread	Use embroidery thread intended for use with this machine. Other embroidery threads may not yield optimum results.
	Bobbin thread	Use embroidery bobbin thread intended for use with this machine.

 **Memo**

- If you use threads other than those listed above, the embroidery may not sew out correctly.

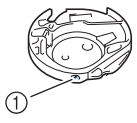
<p>Bobbin case</p>  <p>① Standard bobbin case (green marking on the screw) Alternate bobbin case (no color on the screw)</p>	<p>Standard bobbin case (green marking on the screw) is in the machine for sewing and embroidery. The bobbin case originally installed in the machine has a green marking on the screw. Do not adjust green marked screw.</p> <p>Alternate bobbin case (no color on the screw) is set with tighter tension for embroidery with different weights of bobbin threads and a variety of embroidery techniques. This bobbin case is identified with a dark colored mark on the inside of the bobbin cavity. The screw on this case can be adjusted if necessary.</p>
--	---

See page 326 for how to remove the bobbin case.

CAUTION

- **When embroidering on large garments (especially jackets or other heavy fabrics), do not let the fabric hang over the table. Otherwise, the embroidery unit cannot move freely and the embroidery frame may strike the needle, causing the needle to bend or break and possibly cause injury. Place the fabric so that it does not hang off the table or hold the fabric to keep it from dragging.**

 **Note**

- Before embroidering, check that there is enough thread in the bobbin. If you start to sew your embroidery project without enough thread in the bobbin, you will need to rewind the bobbin in the middle of the embroidery pattern.
- Do not leave objects in the range of motion of the embroidery frame. The frame may strike the object and cause a poor finish to the embroidery pattern.
- When embroidering on large garments (especially jackets or other heavy fabrics), do not let the fabric hang over the table. Otherwise, the embroidery unit cannot move freely, and the pattern may not turn out as planned.

Embroidery Needle Plate Cover

Under some conditions, based on the type of fabric, stabilizer, or thread being used, there may be some looping in the upper thread. In this case, attach the included embroidery needle plate cover to the needle plate. Attach the cover by inserting the two projections on the underside of the cover into the notches on the needle plate as shown below.

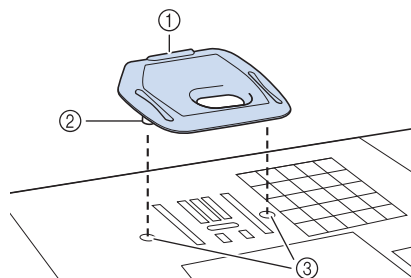

- ① Groove
- ② Projection
- ③ Notch

To remove the embroidery needle plate cover, place your fingernail in the groove and lift the plate out.

CAUTION

- Push the embroidery needle plate cover as far as possible to attach it. If the embroidery needle plate cover is not securely attached, it may cause the needle to break.



Note

- Do not use the embroidery needle plate cover for any applications other than embroidery.

Sewing Embroidery Patterns

Example:

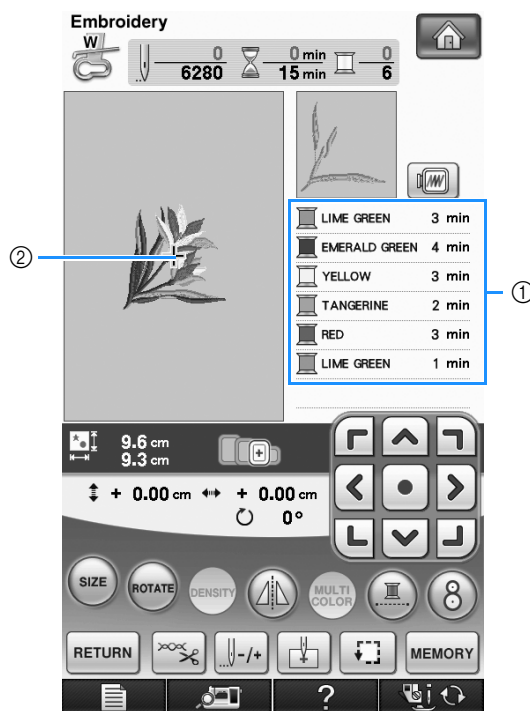

- ① Embroidery color order
- ② Cursor



Memo

- The [+] cursor moves over the pattern, showing which part of the pattern is being sewn.

- 1 Thread the machine with thread for the first color, pass the thread through the hole in embroidery foot "W", pull out some thread to give it some slack, and then lightly hold the end of the thread in your left hand.

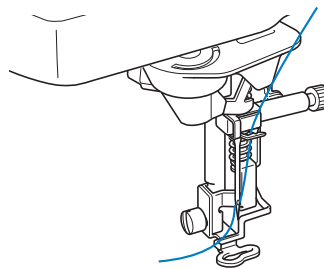

2 Lower the presser foot, then press the “Start/Stop” button to start embroidering. After 5-6 stitches, press the “Start/Stop” button again to stop the machine.

3 Trim the excess thread at the end of the seam. If the end of the seam is under the presser foot, raise the presser foot, then trim the excess thread.

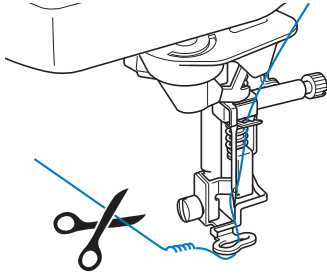

4 Press the “Start/Stop” button to start embroidering.

→ When the first color is completely sewn, the machine will automatically trim the threads and stop. The presser foot will then automatically be raised. On the embroidery color order display, the next color will move to the top.

Memo

- If there is thread left over from the beginning of sewing, it may be sewn over as you continue embroidering the pattern, making it very difficult to deal with the thread after the pattern is finished. Trim the threads at the beginning of each thread change.

5 Remove the thread for the first color from the machine. Thread the machine with the next color.

6 Repeat the same steps for embroidering the remaining colors.

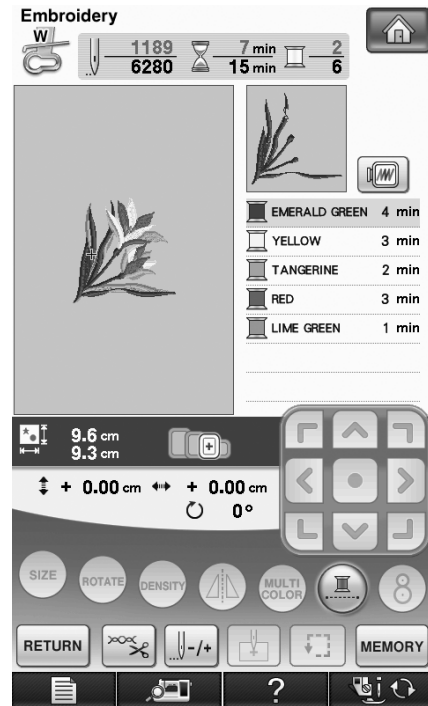

→ When the last color is sewn, “Finished sewing” will appear on the display. Press **OK**, and the display will return to the original screen.

Memo

- The Thread Trimming Function is originally set to trim excess thread jumps (threads linking parts of the pattern, etc.). Depending on the type of thread and fabric that are used, an end of upper thread may remain on the surface of the fabric at the beginning of the stitching. After embroidering is finished, cut off this excess thread.
*If the setting has been turned off, trim the excess thread jumps using scissors after the pattern is finished. See page 230 for information on the thread trimming function.



Sewing Embroidery Patterns Which Use Appliqué

There are some patterns which call for an appliqué inside the pattern. Prepare the base fabric and the appliqué fabric (appliqué piece).

When sewing an embroidery pattern with an appliqué, the color sewing order display shows "APPLIQUE MATERIAL", "APPLIQUE POSITION", "APPLIQUE", and then the sewing order of the colors around the appliqué.



Memo

- Depending on the thread color display setting, the display may show , , or .

- 1 Attach an iron-on stabilizer to the wrong side of the appliqué material.

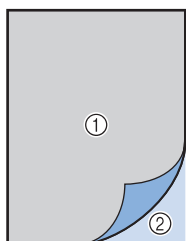

- 1 Appliqué material (cotton, felt, etc.)
- 2 Iron-on stabilizer

- 2 Place the appliqué material into the embroidery frame, and then press the "Start/Stop" button to sew the outline of the appliqué.

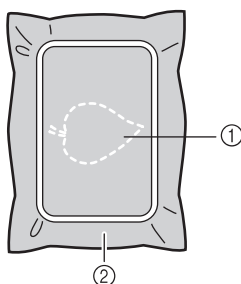

- 1 Outline of appliqué
- 2 Appliqué material



Memo

- The embroidery procedure is the same as the basic procedure explained on page 213.

→ The machine will sew around the outline of the appliqué pieces and will then stop.

- 3 Remove the appliqué material from the embroidery frame, and then cut carefully along the stitching. After cutting, remove all of the stitching thread carefully.

- * Carefully cut out the pattern on the outline you just sewed. Do not cut inside the stitching line, as the appliqué fabric will not be caught by the appliqué stitch.

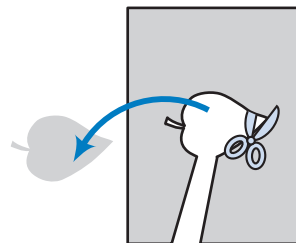

- 4 Place the base material into the embroidery frame.

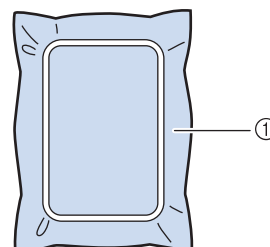

- 1 Base material

- 5 Press the "Start/Stop" button to sew the position of the appliqué.

- * Use the same thread color you plan to use when attaching the appliqué in step 7.

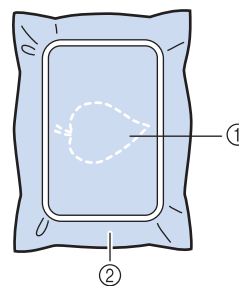

- 1 Position of appliqué
- 2 Base material

→ The machine will sew around the position of the appliqué and will then stop.

- 6** Apply a thin layer of adhesive or spray adhesive to the back of the appliqué piece and attach it to the appliqué position so that it follows the seam of the outline.

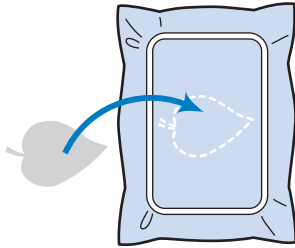

Memo

- If the appliqué material is a lightweight fabric, you may want to use a fusible web on the back to stabilize the fabric and for appliqué placement. Fuse appliqué in place with an iron. Do not remove fabric from the frame to iron the appliqué material.

- 7** Press the “Start/Stop” button.

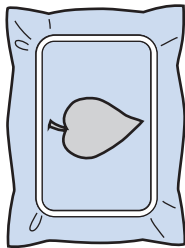

Memo

- Some patterns may not show all three appliqué steps. Sometimes the “APPLIQUE” step will be shown as a color.

→ The appliqué will then be completed.

- 8** Change the upper thread and then carry out the rest of the embroidering.

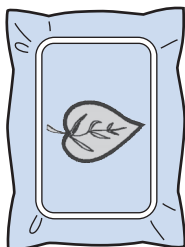

Memo

- Some glue may get onto the presser foot, needle, and needle plate at this time. Finish embroidering the appliqué pattern and then clean away the glue.
- For best sewing results clip all threads between color steps.

PRINT AND STITCH (COMBINING EMBROIDERY PATTERNS AND PRINTED DESIGNS)

Completed embroidery patterns combined with printed designs are built into this machine. Beautiful three-dimensional embroidered designs can be created by ironing a background onto fabric or printing it onto printable fabric, then sewing complementary embroidery on top of the background.

Using iron-on paper

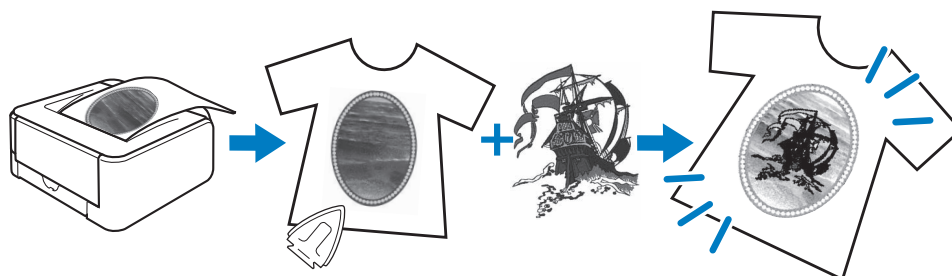

Using printable fabric

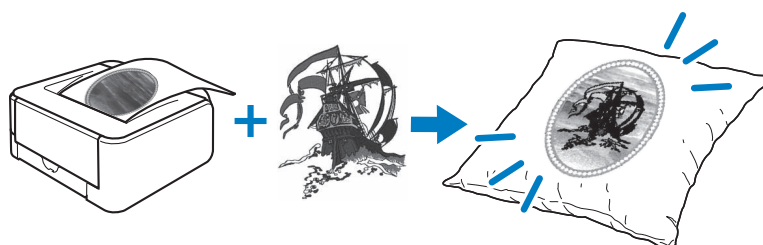

- | | |
|--------------|---|
| Step1 | Select a pattern to be combined with the background image.
→ See “Selecting a Pattern” on page 218. |
| ↓ | |
| Step2 | Output from the machine the background image and the positioning image.
→ See “Outputting the Background Image and Positioning Image” on page 219. |
| ↓ | |
| Step3 | When using iron-on paper
With a printer, print the background onto iron-on paper, and print the embroidery position sheet on plain paper. Then, iron the background image onto fabric.
When using printable fabric
With a printer, print the background onto printable fabric, and print the embroidery position sheet on plain paper.
→ See “Printing the Background and Embroidery Position Sheet” on page 221. |
| ↓ | |
| Step4 | Hoop in the embroidery frame the fabric with the background image ironed on or printed, check the embroidering position, and then start embroidering.
→ See “Sewing Embroidery Patterns” on page 222. |



Note

- Print the background and embroidery position sheet in their original dimensions. If an image is printed in a different size, the sizes of the embroidery pattern and background may not match. In addition, the built-in camera cannot detect the embroidery position mark. Make sure that the print settings are correctly specified.

Selecting a Pattern

Patterns combining embroidery and printed designs can be selected from the pages that contain . Select the desired pattern.

Memo

- Refer to the Quick Reference Guide for the detail of patterns which enable this function.

1 Press the key of the pattern you want to embroider.

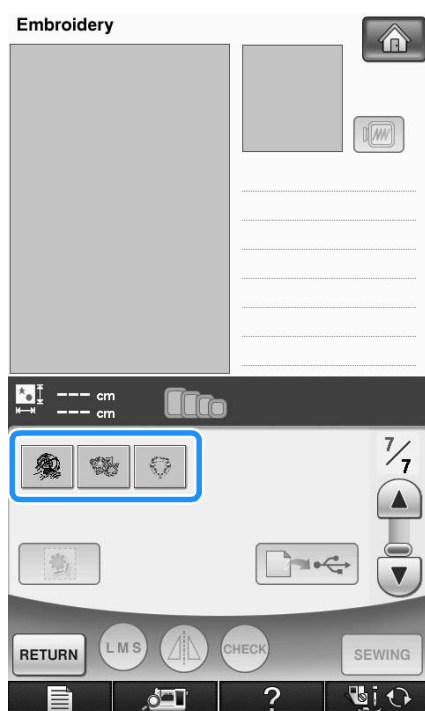

→ An image of the pattern combined with the background appears.

■ Checking Only the Embroidery Pattern

Press .



→ Only the embroidery pattern (not the background image of the selected embroidery pattern) is displayed.

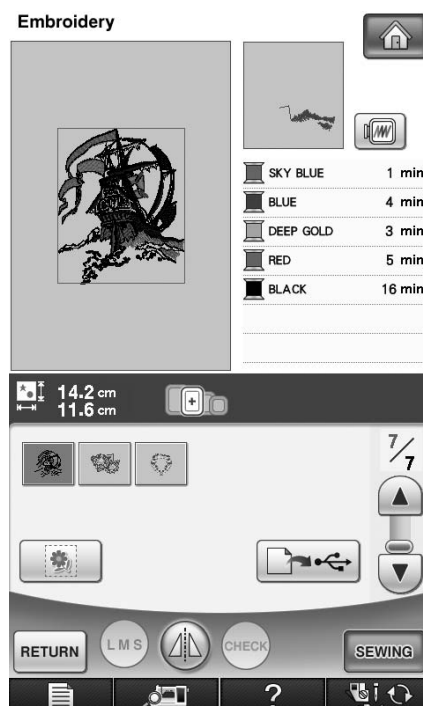

* To return to the image of the pattern combined with the background, press .

Outputting the Background Image and Positioning Image

Use USB media or the computer to output the following three images from the machine.

- * File name may differ depending on the PDF file selected.
- **[xxx]r.pdf (Example: E_1r.pdf)**
An image flipped on a vertical axis (for an iron-on transfer)

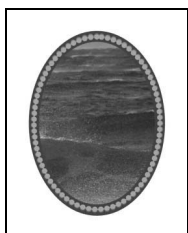

- **[xxx]n.pdf (Example: E_1n.pdf)**
An image that is not flipped (for printing on printable fabric)

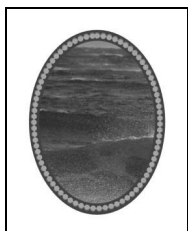

- **[xxx]p.pdf (Example: E_1p.pdf)**
An image that is not flipped, but has positioning marks attached (for positioning)

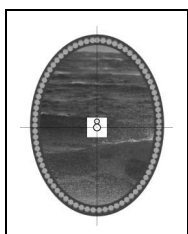

Note

- Print the background and embroidery position sheet in their original dimensions. If an image is printed in a different size, the sizes of the embroidery pattern and background may not match. In addition, the built-in camera cannot detect the embroidery position mark. Make sure that the print settings are correctly specified.
- When printing the PDF file of the image with positioning marks, specify the highest image quality possible for full-color printing. In addition, use matte printing paper. Due to poor printing conditions, the machine's built-in camera may not be able to correctly detect the positioning marks. (For details on printing, refer to the operating instructions for your printer.)

Using USB Media

- 1 Insert the USB media into the primary (top) USB port on the machine.
- 2 Select the pattern, and then press .



→ The select USB output screen appears.

- 3** Press  to select the primary (top) USB port where the USB media is inserted.

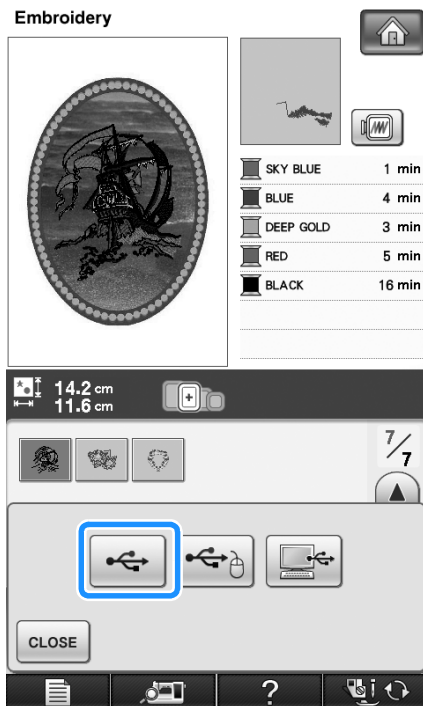

→ Two files of the background image only and one file for aligning embroidery into position are copied (PDF format) onto the USB media.

 **Memo**

- Do not remove the USB media from the machine until data output is finished.

- 4** Remove the USB media where the image data is saved from the machine, and then copy the image data from the USB media to the computer.

Using a USB Cable

- 1** Plug the USB cable connectors into the corresponding USB ports on the computer and on the machine.

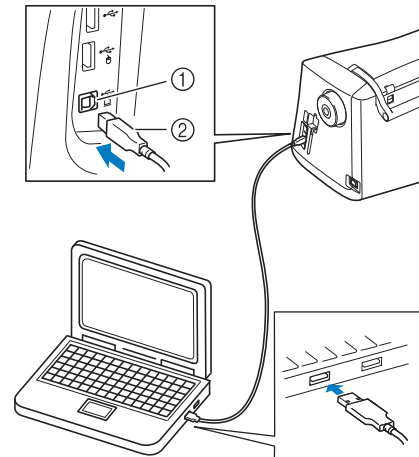

- ① USB port for computer
 ② USB cable connector
 → The "Removable Disk" icon appears in "Computer (My computer)" on the computer.

- 2** Select the pattern, and then press .



→ The select USB output screen appears.

3 Press .



→ Two files of the background image and one file for aligning embroidery into position are copied (PDF format) into "Removable Disk" under "Computer (My computer)".

Memo

- Do not disconnect the USB cable from the machine until data output is finished.

4 Copy the image data saved in "Removable Disk" into a different file before closing.

Printing the Background and Embroidery Position Sheet

Print the PDF files of the background and embroidery position sheet. The background file that is printed differs depending on whether iron-on paper or printable fabric is used.

To view the PDF file, Adobe® Reader® is needed. If it is not installed on your computer, you can download it from the Adobe Systems website: <http://www.adobe.com/>

1 Open the PDF file to be printed, click "File"->"Print", and then set "Page Scaling" to "None (100%)".

Note

- Print the background and embroidery position sheet in their original dimensions. If an image is printed in a different size, the sizes of the embroidery pattern and background may not match. In addition, the built-in camera cannot detect the embroidery position mark. Make sure that the print settings are correctly specified.

2 Print the background image.

- * When printing onto iron-on paper, print the file named E_1r.pdf (an image flipped on a vertical axis). When printing onto printable fabric, print the file named E_1n.pdf (an image that is not flipped).

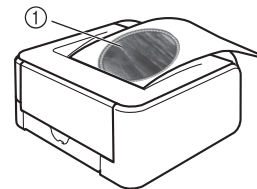

① Background image

Note

- Before printing onto iron-on paper or printable fabric, we recommend performing a test print to check the print settings.
- For details on printing on iron-on transfer sheets or printable fabric, refer to the instructions for the iron-on transfer sheets and printable fabric.
- Some printers will automatically print an image flipped if an iron-on transfer sheet is selected as the paper. For details, refer to the instructions for the printer being used.

3 Print the embroidery position sheet (file named E_1p.pdf) onto plain paper.

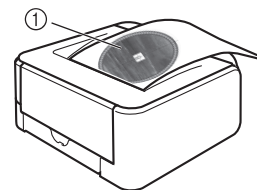

① Embroidery position sheet

Note

- When printing the PDF file for the embroidery position sheet, specify the highest image quality possible for full-color printing. In addition, we recommend printing on matte paper. If this is not done, the built-in camera may not be able to correctly detect the embroidery positioning mark.

- 4** If an iron-on transfer sheet is used, transfer the image onto fabric.



Memo

- For details on transferring from iron-on transfer sheets, refer to the instructions for the iron-on transfer sheets.
- If necessary, cut the iron-on transfer sheet to the size of the pattern before transferring the image.

Sewing Embroidery Patterns

- 1** Hoop in the embroidery frame the fabric with the background image ironed on.

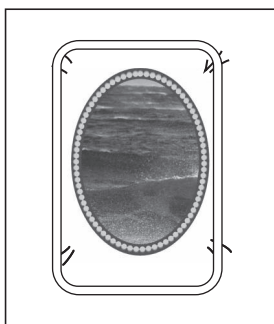

- 2** Cut the paper printed with the center positioning image 8 so it can easily be positioned aligned with the background image on the fabric.

* Lines or color changes in the image can help you find the correct alignment position.

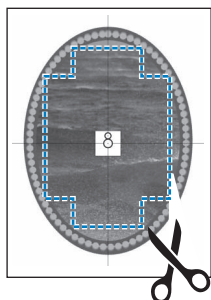

- 3** Place the paper printed with the positioning image on top of the fabric so that the pattern is aligned, and then affix the paper to the fabric with cellophane tape to prevent the paper from moving.

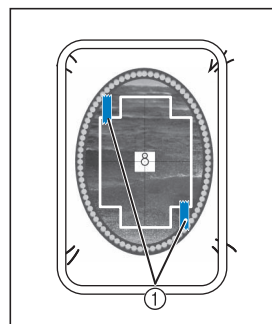

① Cellophane tape

- 4** After checking that a pattern is selected, press **SEWING**.

→ The sewing screen appears.



Note

- Before embroidering, check that the embroidery position sheet is perfectly aligned with the background.

- 5** Align the embroidering position according to steps 2 through 6 of “Using the Built-In Camera to Align the Embroidering Position” on page 206.
- 6** Remove the positioning sheet and press the “Start/Stop” button to begin embroidering.

CAUTION

- Before pressing the “Start/Stop” button to begin embroidering, remove the positioning sheet taped to the fabric in step 3.



ADJUSTMENTS DURING THE EMBROIDERY PROCESS



Note

- Be careful not to bump the embroidery unit carriage or the presser foot when removing or attaching the embroidery frame. Otherwise, the pattern will not embroider correctly.

If the Bobbin Runs Out of Thread

When the bobbin begins to run out of thread during embroidering, the machine will stop and the message below will appear. Press  and follow the directions below to rethread the lower threading. If very little sewing remains, you can embroider 10 final stitches without rethreading the machine by pressing . The machine will stop after sewing the 10 stitches.

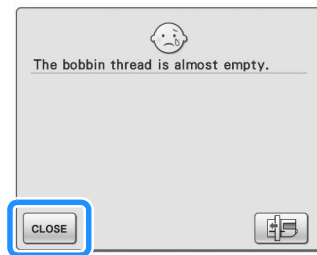

Note

- If "Upper and Bobbin Thread Sensor" in the General settings screen of the machine setting mode is set to "OFF", the message shown above does not appear.

1

Press .

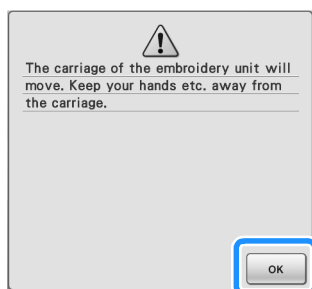

→ After the thread is automatically cut, the carriage will move.

2

Unlock the frame-securing lever and remove the embroidery frame.

- * Be careful not to apply strong force to the fabric at this time. Otherwise, the fabric may loosen in the frame.

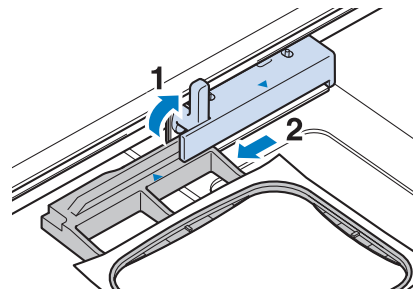

3

Insert a wound bobbin into the machine. (see page 43 for Setting the bobbin.)

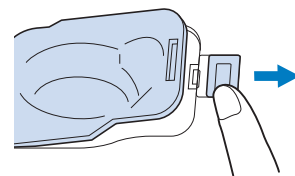

4

Press .

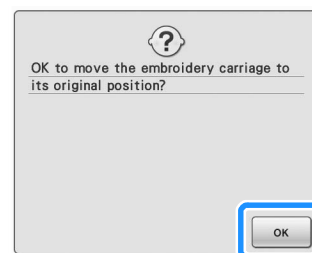



→ The carriage will return to its original position.

5

Attach the embroidery frame.



6

To return to the spot in the pattern where you stopped sewing, follow steps  through  in the next section.



5



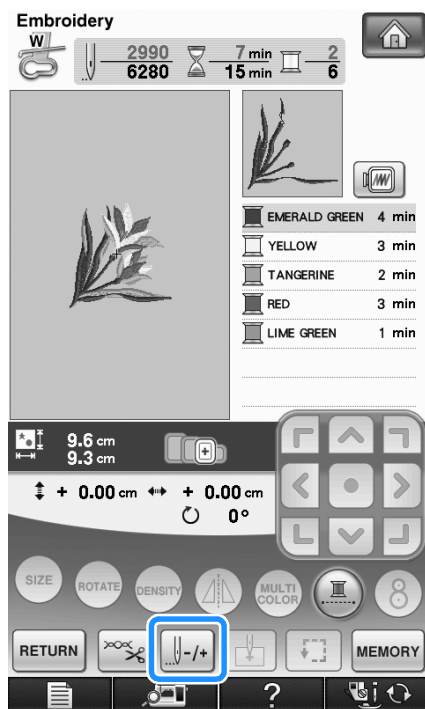

Embroidery

If the Thread Breaks During Sewing

- 1 Press the “Start/Stop” button to stop the machine.
- 2 If the upper thread is broken, redo the upper threading. If the bobbin thread is broken, press  and follow the directions in steps 1 through 5 from the previous section to reset the bobbin.
- 3 Press .



- 4 Press , , or  to move the needle back the correct number of stitches before the spot where the thread broke.

* If you cannot move back to the spot where the thread broke, press  to select the color and move to the beginning position of that color, then use , , or  to move ahead to slightly before where the thread broke.

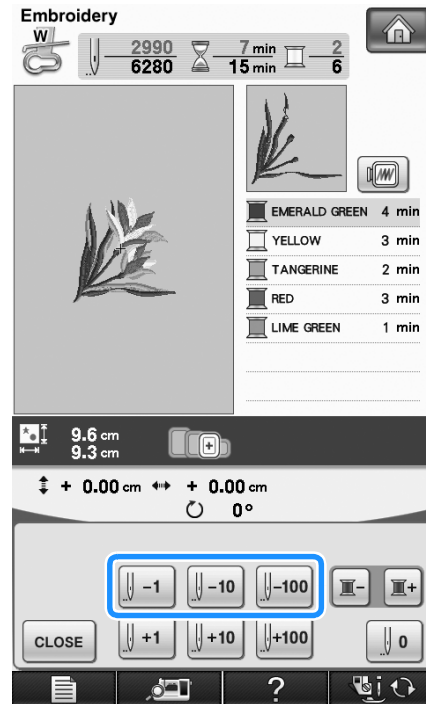

- 5 Press  to return to the original screen.
- 6 Press the “Presser Foot Lifter” button to lower the presser foot, and press the “Start/Stop” button to continue sewing.

Restarting from the Beginning

- 1 Press .

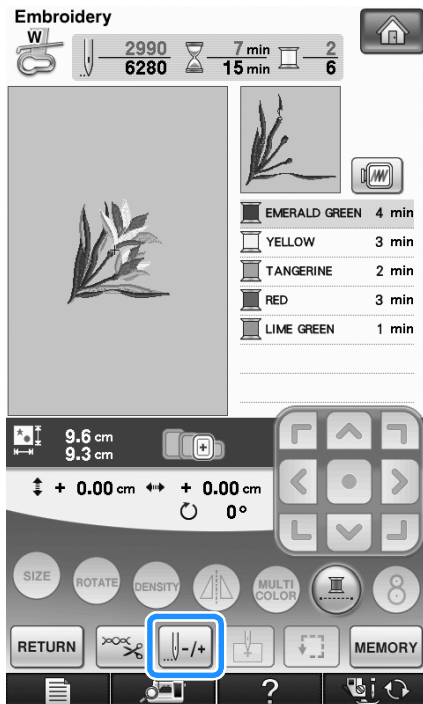

- 2 Press .

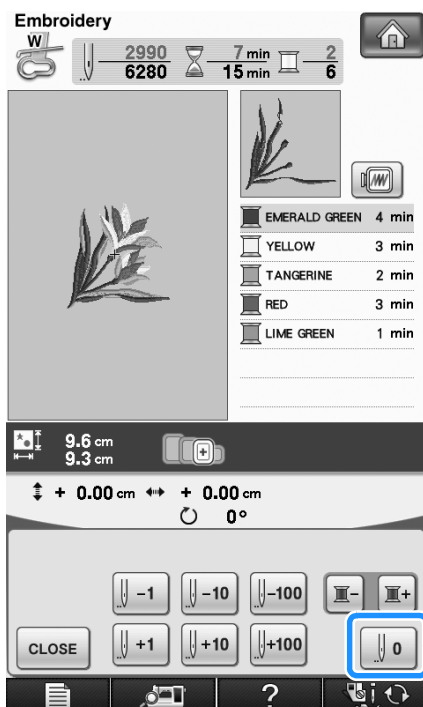

→ The embroidery frame moves, returning the needle to the pattern's beginning position.

- 3 Press the "Presser Foot Lifter" button to lower the presser foot and start sewing.

Resuming Embroidery After Turning Off the Power

The current color and stitch number are saved when embroidery is stopped. The next time the machine is turned on, you have the option to continue or delete the pattern.

Memo

- Even if the power goes out in the middle of embroidery, the machine returns to the point where embroidery was stopped when the machine is turned on again.

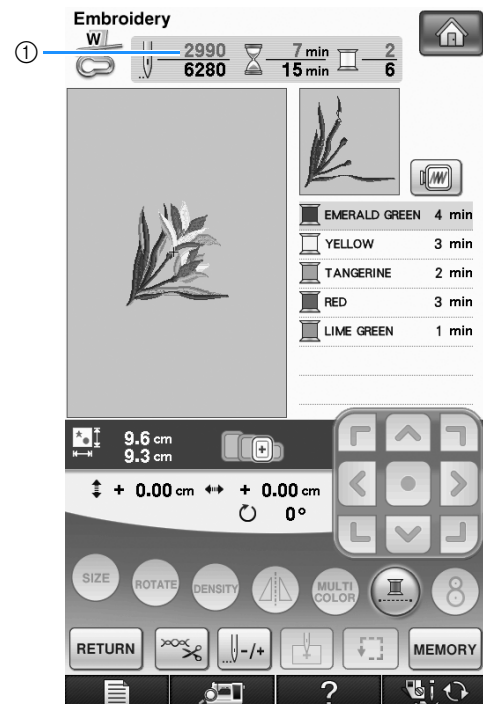

- ① Current stitch number when embroidery was stopped

Note

- Do not remove the embroidery unit or the memory will no longer remember your design.

- 1 Turn the main power to ON.
- 2 Follow the instructions shown on the screen and remove the embroidery frame.

→ The following message will appear.

3 Attach the embroidery frame and press

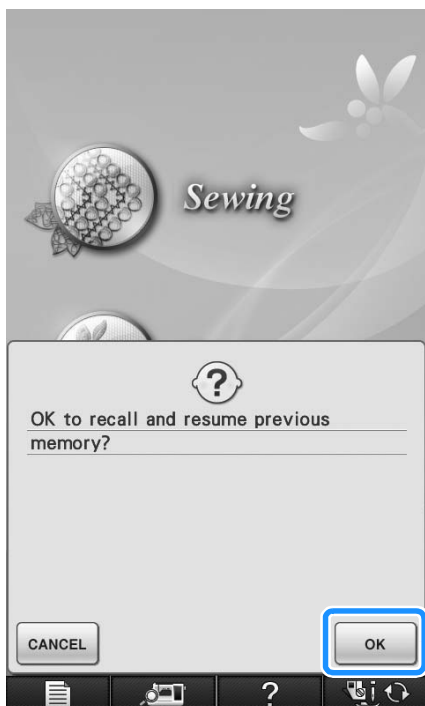

→ The previous sewing screen displayed before the machine was turned off appears.

Memo

- If you want to start a new embroidery pattern, press so the pattern selection screen appears.

4 Continue embroidering.

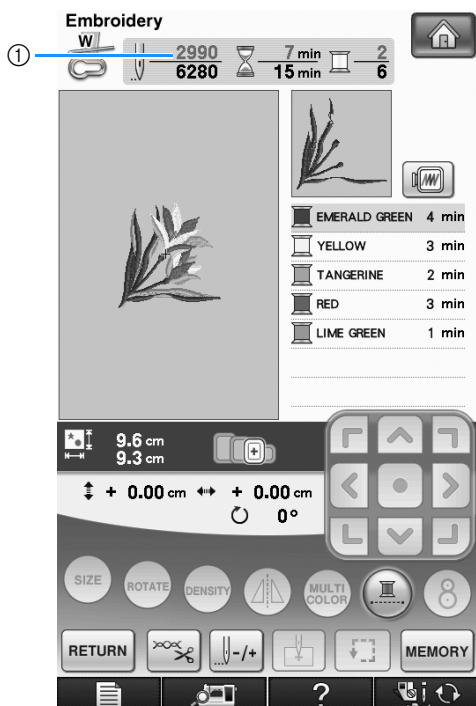

① Stitch number when embroidery is resumed

MAKING EMBROIDERY ADJUSTMENTS

Adjusting Thread Tension

When embroidering, the thread tension should be set so that the upper thread can slightly be seen on the wrong side of the fabric.

Correct Thread Tension

The pattern can be seen from the wrong side of the fabric. If the thread tension is not set correctly, the pattern will not finish well. The fabric may pucker or the thread may break.

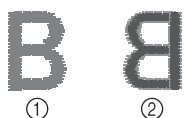

- ① Right side
- ② Wrong side

Follow the operations described below to adjust thread tension according to the situation.

Note

- If the thread tension setting is made extremely weak, the machine may stop during sewing. This is not the sign of a malfunction. Increase the thread tension slightly, and begin sewing again.

Memo

- If you turn the main power to OFF or select a different pattern, the thread tension will reset to the automatic setting.
- When you retrieve a saved pattern, the thread tension setting will be the same as when the pattern was saved.

Upper Thread is Too Tight

The tension of the upper thread is too tight, resulting in the bobbin thread being visible from the right side of the fabric.

Note

- If the bobbin thread was incorrectly threaded, the upper thread may be too tight. In this case, refer to “Setting the Bobbin” (page 43) and rethread the bobbin thread.



- ① Right side
- ② Wrong side

1 Press .

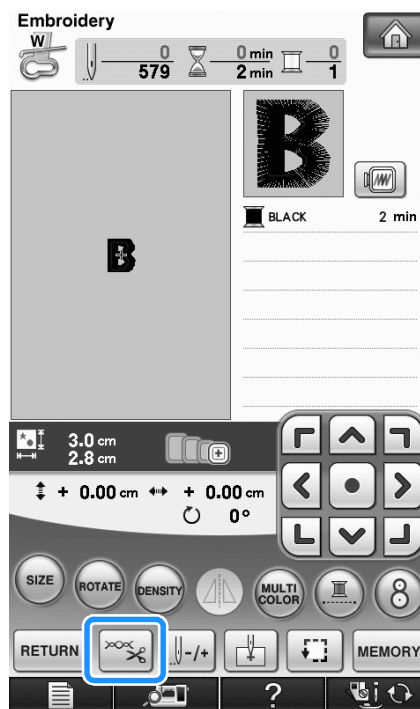

2 Press  to weaken the upper thread tension. (The tension number will decrease.)

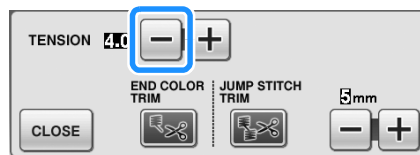

3 Press .

5

Embroidery

■ Upper Thread is Too Loose

The tension of the upper thread is too loose, resulting in a loose upper thread, loose thread locks, or loops appearing on the right side of the fabric.

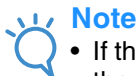

Note

- If the upper thread was incorrectly threaded, the upper thread may be too loose. In this case, refer to “Upper Threading” (page 46) and rethread the upper thread.

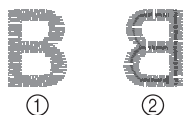

- ① Right side
- ② Wrong side

1 Press .

2 Press to tighten the upper thread tension. (The tension number will increase.)

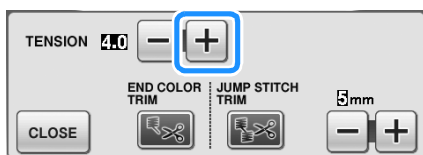

3 Press .

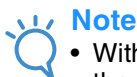

Note

- With “Embroidery Tension” on page 6/7 of the setting screen, the tension of the upper thread can be adjusted for embroidering. The selected setting will be applied to all patterns. When embroidering, if the overall tension of the upper thread is too tight or too loose, adjust it from the setting screen. Press to tighten the upper thread tension and press to loosen the upper tension. If an individual embroidery pattern needs additional fine tuning, refer to “Adjusting Thread Tension” on page 227.

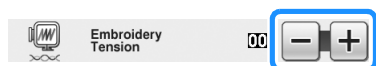

Adjusting the Alternate Bobbin Case (with No Color on the Screw)

When using the embroidery bobbin thread provided, please be sure to choose the green marked bobbin case when performing utility stitch sewing and embroidery functions. When in the embroidery function mode, the alternate bobbin case (with no color on the screw) should be selected when substitute embroidery bobbin threads (other than what is accompanied with your machine) are being used. The alternate bobbin case (with no color on the screw) can be easily adjusted when bobbin tension changes are required to accommodate different bobbin threads. See “Sewing Attractive Finishes” on page 212.

To adjust the bobbin tension for embroidery function, using the alternate bobbin case (with no color on the screw), turn the slotted screw (-) with a (small) screwdriver.

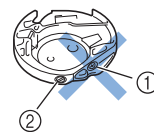

- ① Do not turn a phillips screw (+).
- ② Adjust with a screwdriver (small).

■ Correct Tension

Upper thread slightly appears on the wrong side of fabric.

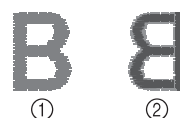

- ① Right side
- ② Wrong side

■ Bobbin Thread is Too Loose

Bobbin thread appears slightly on the right side of fabric.



- ① Right side
- ② Wrong side

If this occurs, turn the slotted screw (-) clockwise, being careful not to over-tighten the screw, approximately 30-45 degrees to increase bobbin tension.

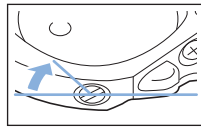

■ Bobbin Thread is Too Tight

Upper thread on the right side of fabric seems to be lifting/looping and bobbin thread is not seen on the wrong side of fabric.

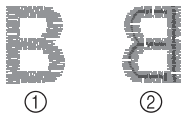

- ① Right side
- ② Wrong side

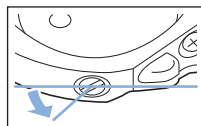

If this occurs, turn the slotted screw (-) counterclockwise, being careful not to over-loosen the screw, approximately 30-45 degrees to decrease bobbin tension.



! CAUTION

- When adjusting the alternate bobbin case, be sure to remove the bobbin from the alternate bobbin case.
- **DO NOT** adjust the position of the phillips (+) screw on the alternate bobbin case as this may result in damage to the bobbin case, rendering it unusable.
- If the slotted screw (-) is difficult to turn, do not use force. Turning the screw too much or providing force in either (rotational) direction may cause damage to the bobbin case. Should damage occur, the bobbin case may not maintain proper tension.

Using the Automatic Thread Cutting Function (END COLOR TRIM)

The automatic thread cutting function  will cut the thread at the end of sewing each color. This function is initially turned on. To turn this function off, press  key and then . This function can be turned on or off during embroidering.

* This setting returns to its default  when the machine is turned off.

1 Press .

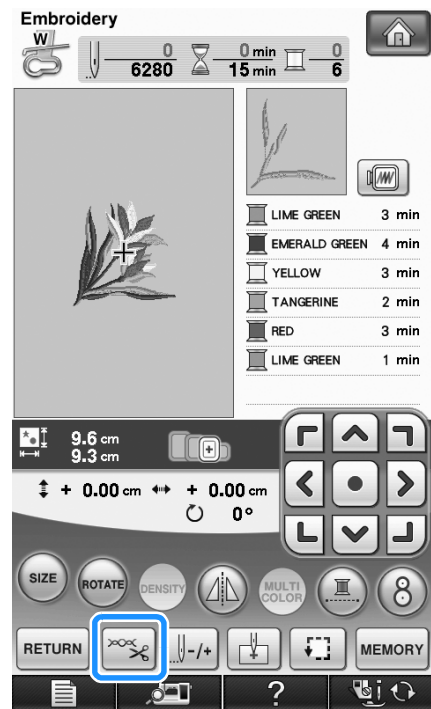



2 Press  to turn off the automatic thread cutting function.



→ The key will display as .

* When one color thread is sewn, the machine will stop without cutting the thread.

Using the Thread Trimming Function (JUMP STITCH TRIM)

The thread trimming function  will automatically trim any excess thread jumps within the color. This function is initially turned on. To turn this function off, press  key and then . This function can be turned on or off during embroidering.

- * Your customized setting remains after turning the machine off and on.

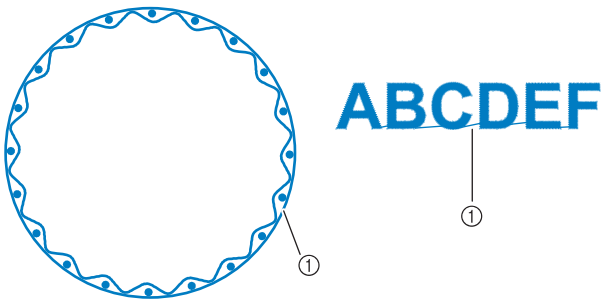

① Jump stitch

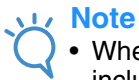

Note

- When this function is turned on, use the included ball point needle 75/11 for embroidering patterns with short jump stitches such as alphabet characters. Using other needles may cause the thread to break.

1 Press .

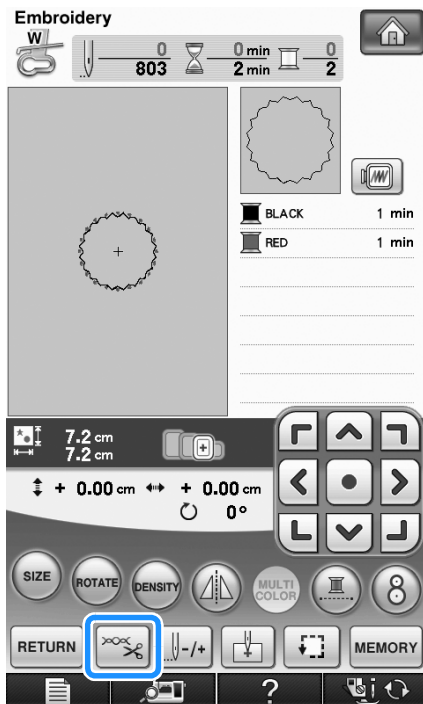

2 Press  to turn off the thread trimming function.





→ The key will display as .

- * The machine will not trim the thread before moving to the next stitching.

Selecting the Length of Jump Stitch Not to Trim

When the thread trimming function  is turned on, you can select the length of the jump stitch not to trim the thread. This function can be turned on or off during embroidering. Select a setting from 5 mm to 50 mm in 5 mm increments.

- * Your customized setting remains after turning the machine off and on.

Press  or  to select the length of jump stitch.

For example: Press  to select 25 mm (1 inch) and the machine will not trim a jump stitch of 25 mm or less before moving to the next stitching.

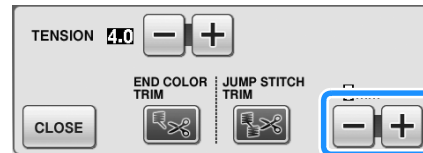

Note

- If design has many trims it is recommended to select a higher jump stitch trim setting in order to reduce the amount of excess tails on backside of fabric.
- The higher number of the jump stitch length selected, the fewer number of times the machine will trim. In this case, more jump stitches remain on the surface of the fabric.

Adjusting the Embroidery Speed

1 Press and .

2 In the “Max Embroidery Speed” display, use

to change the maximum embroidery speed.

* You can choose from 3 different speed levels.

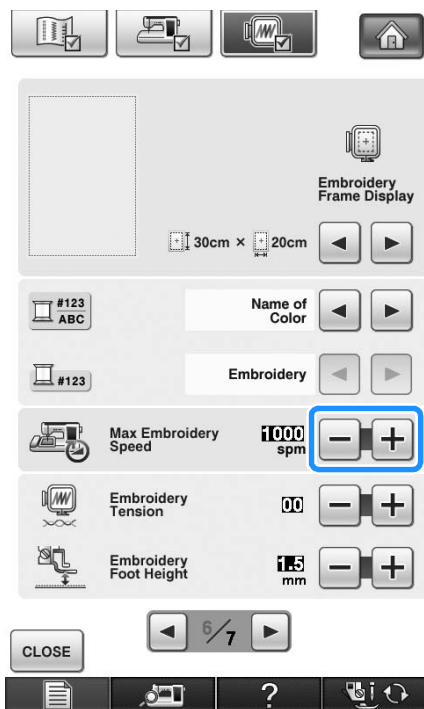

Memo

- SPM is the number of stitches sewn in one minute.
- Decrease the sewing speed when embroidering on thin, thick, or heavy fabrics.
- The sewing speed can be changed while embroidery is being sewn.
- The maximum sewing speed setting does not change until a new setting is selected. The setting specified before the main power is set to OFF remains selected the next time that the machine is turned on.
- Decrease the sewing speed to 600 spm when using a speciality thread like a metallic thread.

3 Press .

Changing the Thread Color Display

You can display the name of the thread colors or embroidery thread number.

Memo

- Colors on the screen may vary slightly from actual spool colors.

1 Press .

2 Press .

3 In the “Thread Color Display”, use to display the name of the thread colors or the embroidery thread number.

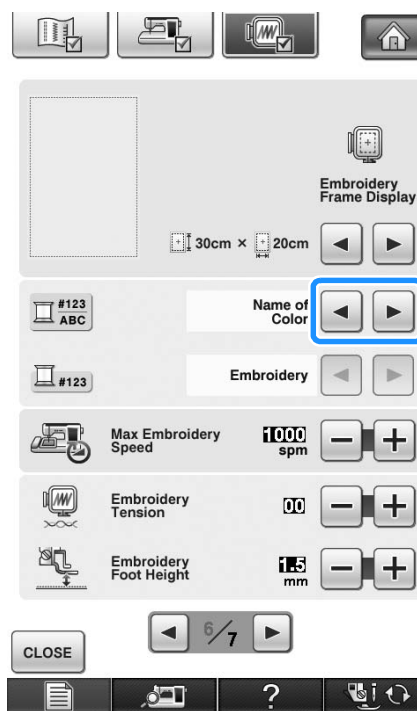

4 When the thread number **#123** is displayed, use to select from six embroidery thread brands pictured below.

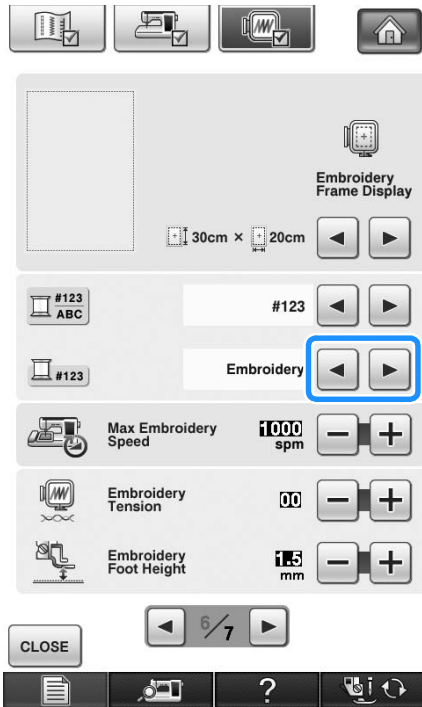

EMBROIDERY/POLYESTER THREAD#

- 509 Embroidery
- 804 Embroidery
- 085 Embroidery

COUNTRY/COTTON THREAD#*

- 463 Country
- 804 Country
- 155 Country

MADEIRA /POLYESTER THREAD#

- 1749 Madeira Poly
- 1630 Madeira Poly
- 1921 Madeira Poly

MADEIRA RAYON THREAD#

- 1050 Madeira Rayon
- 1261 Madeira Rayon
- 1108 Madeira Rayon

SULKY THREAD#

- 1510 Sulky
- 1193 Sulky
- 1224 Sulky

ROBISON-ANTON/POLYESTER THREAD#

- 5514 R-A Poly
- 5586 R-A Poly
- 5523 R-A Poly

* Depending on the country or area, cotton-like polyester thread is sold.

5 Press .

Changing the Embroidery Frame Display

1 Press .

2 Press .

3 In the "Frame Display", use to change the embroidery frame display mode.

* There are 14 choices.

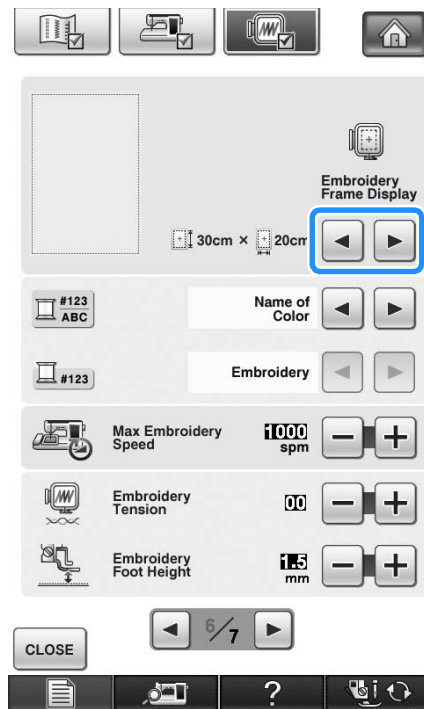

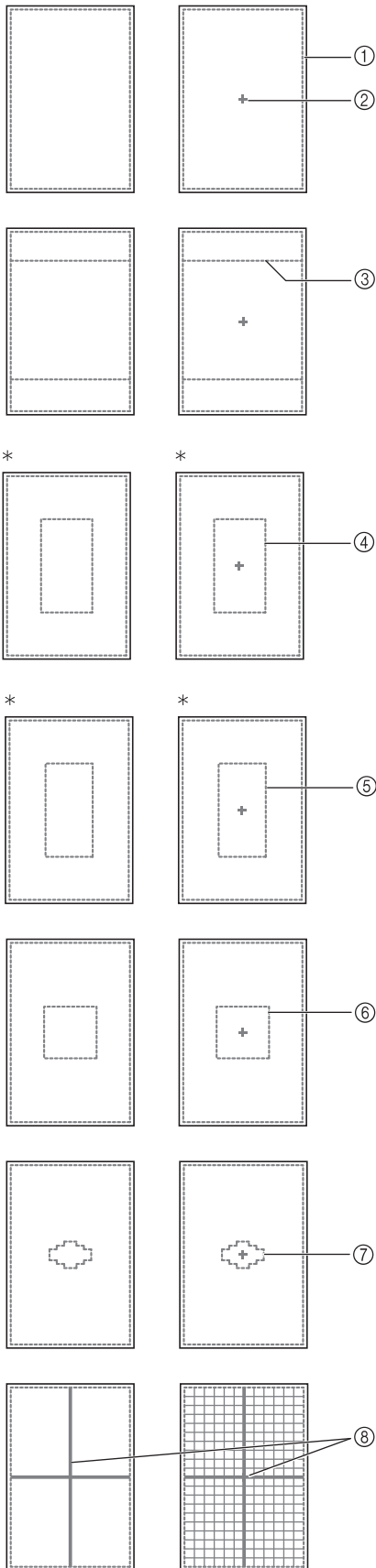

- ① Extra large frame embroidering area
[30 cm × 20 cm (12 inches × 8 inches)]
- ② Center line
- ③ Quilt frame embroidering area
[20 cm × 20 cm (8 inches × 8 inches)]
- ④ Embroidery area for optional large embroidery
frame [18 cm × 13 cm (7 inches × 5 inches)]
- ⑤ Embroidering area for optional border embroidery
frame [18 cm × 10 cm (7 inches × 4 inches)]
- ⑥ Medium frame embroidering area
[10 cm × 10 cm (4 inches × 4 inches)]
- ⑦ Small frame embroidering area
[2 cm × 6 cm (1 inch × 2-1/2 inches)]
- ⑧ Grid lines

4 Press .

* For the optional embroidery frame.

REVISING THE PATTERN

⚠ CAUTION

- When you have revised the pattern, check the display of available embroidery frames and use an appropriate frame. If you use an embroidery frame not displayed as available for use, the presser foot may strike the frame and possibly cause injury.

Changing the Pattern Position

Use  to move the pattern in the direction shown by the arrow.

Press  to center the pattern.

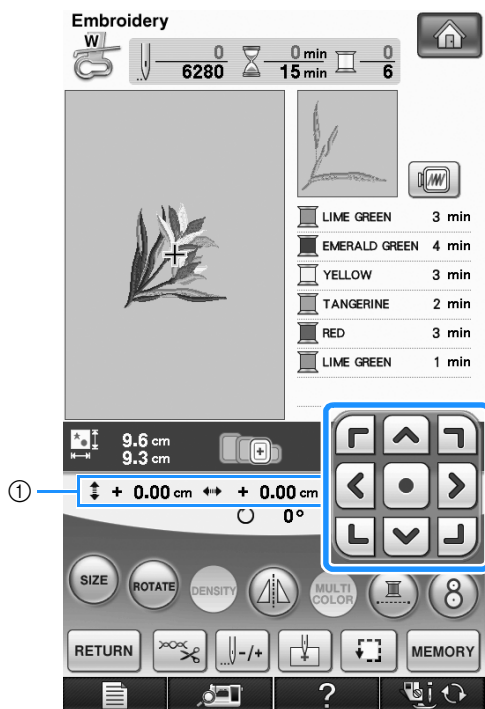

① Distance from the center

The pattern can also be moved by dragging it.

If a USB mouse is connected, move the mouse to position the pointer on the desired pattern, and then select and drag the pattern. The pattern can also be dragged by selecting it directly in the screen with your finger or the touch pen.

Memo

- Patterns cannot be moved in screens where



does not appear.

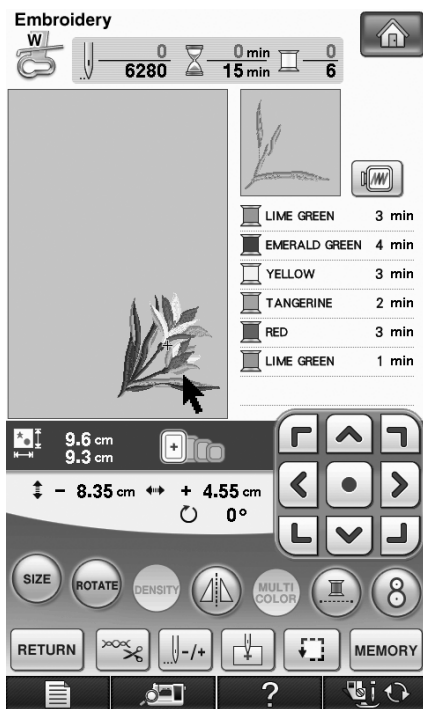
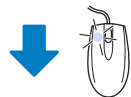
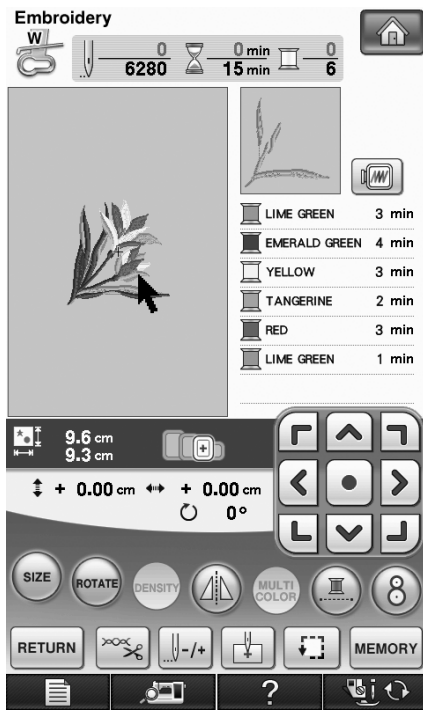

Aligning the Pattern and the Needle

Example: Aligning the lower left side of a pattern and the needle

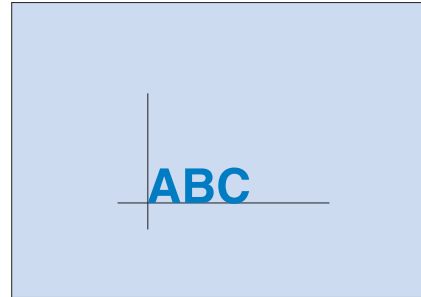

1 Mark the embroidery start position on the fabric, as shown.

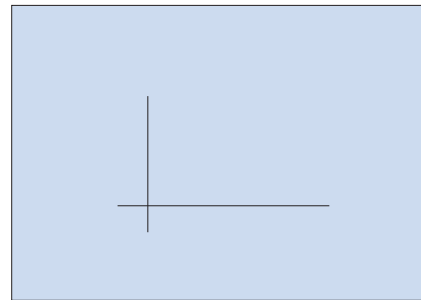

2 Press .

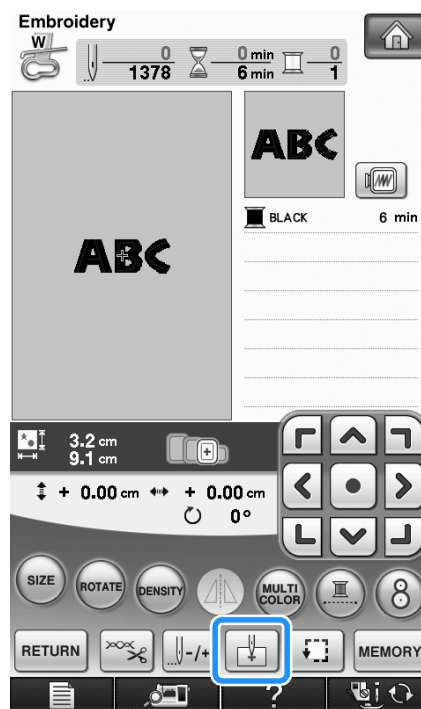

3 Press .

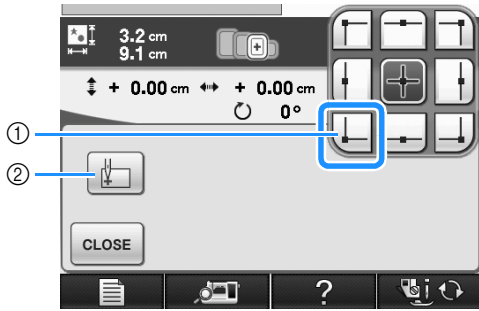

- ① Start position
- ② This key is used for aligning linked characters (see page 241).
→ The needle position moves to the bottom left corner of the pattern (the embroidery frame moves so that the needle is positioned correctly).

4 Press .

5 Use  to align the needle and the mark on the fabric, and begin embroidering the pattern.

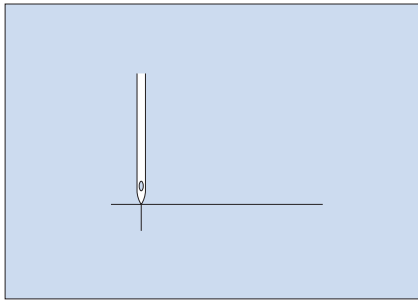





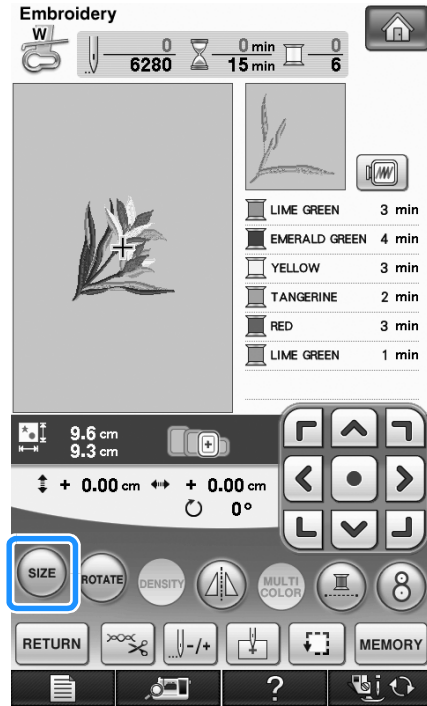

Changing the Size

1 Press .



2 Select the direction in which to change the size.

- * Press  to enlarge the pattern proportionately.
- * Press  to shrink the pattern proportionately.
- * Press  to stretch the pattern horizontally.
- * Press  to compact the pattern horizontally.
- * Press  to stretch the pattern vertically.
- * Press  to compact the pattern vertically.
- * Press  to return the pattern to its original appearance.

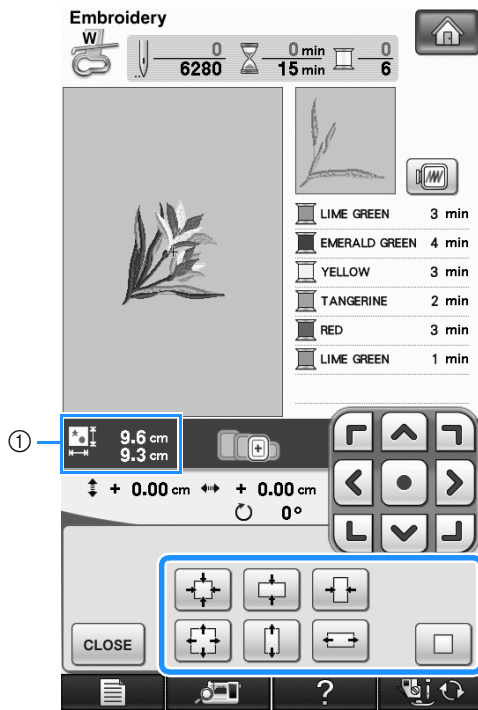

① Size of the pattern

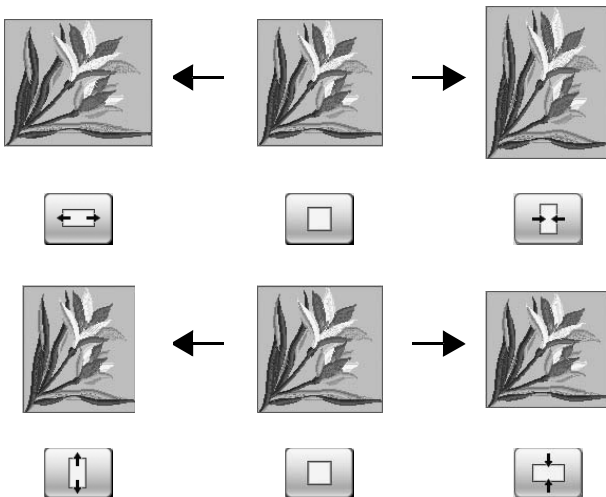

Memo

- Some patterns or characters can be enlarged more than others.
- Some patterns or characters can be enlarged to a greater degree if they are rotated 90 degrees.

3 Press **CLOSE** to return to the original screen.

Rotating the Pattern

1 Press **ROTATE**.

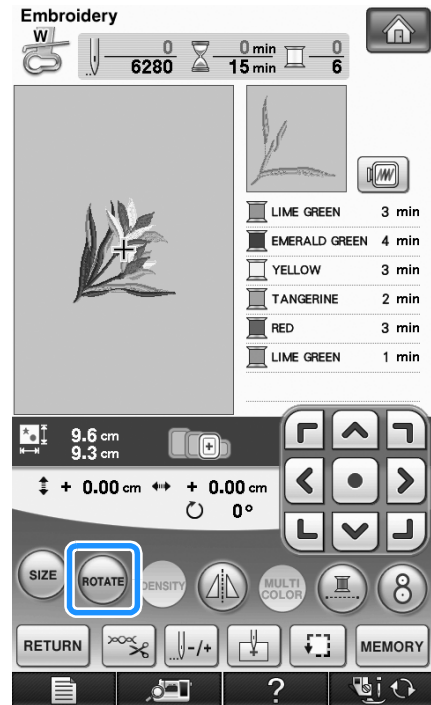

2 Select the angle of rotation for the pattern.

- * Press **90°** to rotate the pattern 90 degrees to the left.
- * Press **90°** to rotate the pattern 90 degrees to the right.
- * Press **10°** to rotate the pattern 10 degrees to the left.
- * Press **10°** to rotate the pattern 10 degrees to the right.
- * Press **1°** to rotate the pattern 1 degree to the left.
- * Press **1°** to rotate the pattern 1 degree to the right.

* Press **RESET** to return the pattern to its original position.

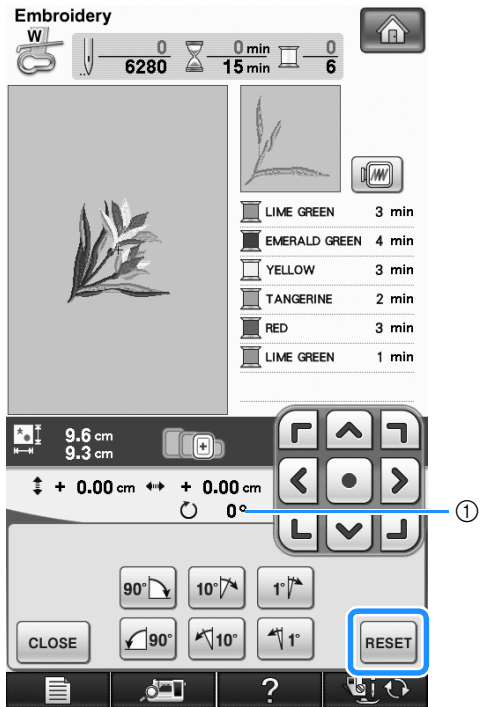

① Degree of rotation

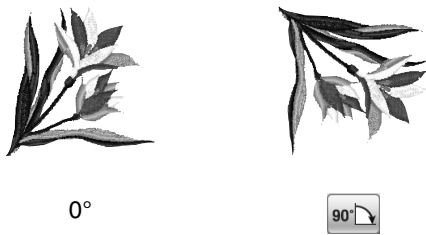

3 Press **CLOSE** to return to the original screen.

Creating a Horizontal Mirror Image

Press so it appears as to create a horizontal mirror image of the selected pattern.

Press again to return the pattern to normal.

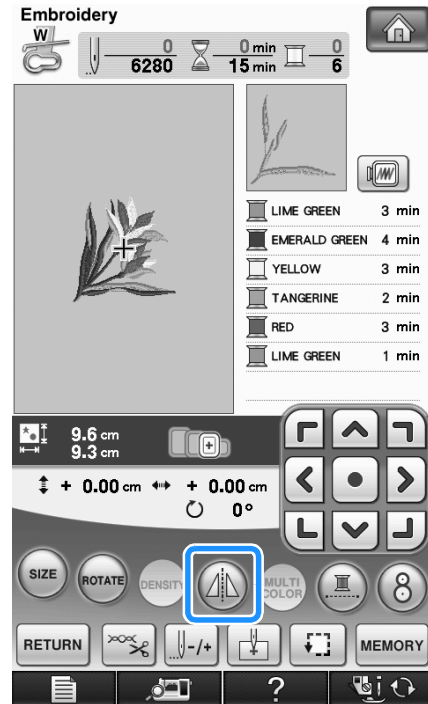

Changing the Density (Alphabet Character and Frame Patterns Only)

The thread density for some alphabet character and frame patterns can be changed.

A setting between 80% and 120% in 5% increments can be specified.

1 Press **DENSITY**.

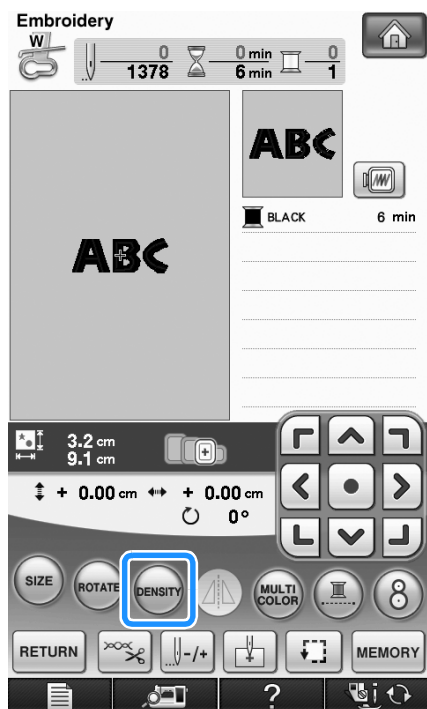

2 Change the density.

- * Press **-** to make the pattern less dense.
- * Press **+** to make the pattern more dense.

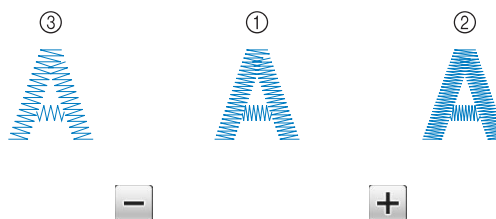
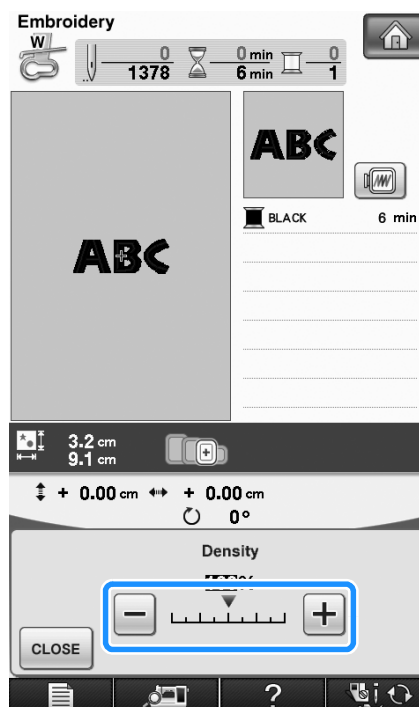

- ① Normal
 - ② Fine (stitches closer together)
 - ③ Coarse (stitches farther apart)
- The pattern density changes each time you press a button.

3 Press **CLOSE** to return to the pattern selection screen.

5

Embroidery

Changing the Colors of Alphabet Character Patterns

Combined alphabet character patterns can be sewn with each letter in a different color. If "MULTI COLOR" is set, the machine stops after each character is sewn so that the thread can be changed to a different color.

1 Press  so that it appears as .

* Press the key again to return to the original setting.

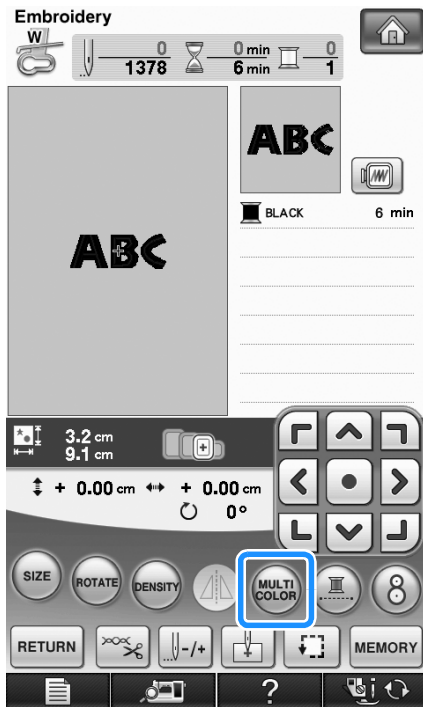

2 After a character is sewn, change the thread color, and then sew the next character.

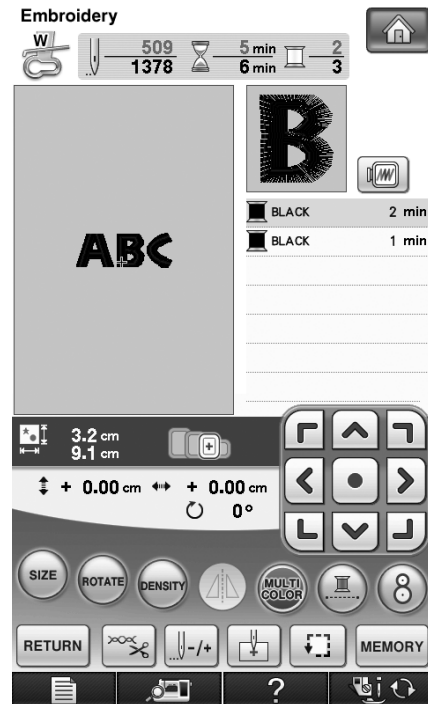

Embroidering Linked Characters

Follow the procedure described below to embroider linked characters in a single row when the entire pattern extends beyond the embroidery frame.

Example: Linking “DEF” to the characters “ABC”

A B C D E F

1 Select the character patterns for “ABC”.



Note

- For details on selecting character patterns, refer to “Selecting Alphabet Character Patterns” on page 190.

2 Press .

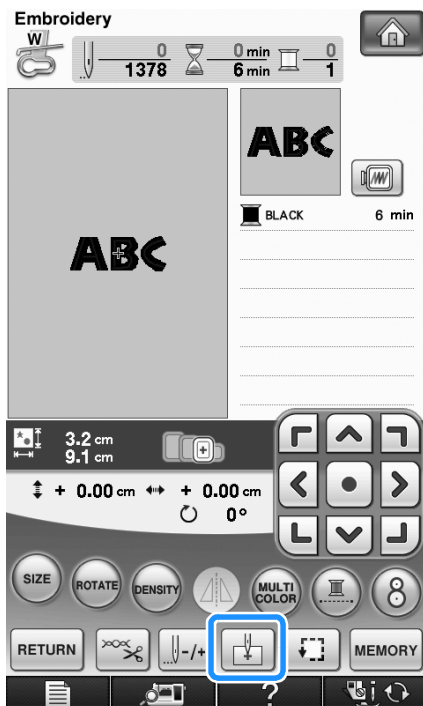

3 Press .

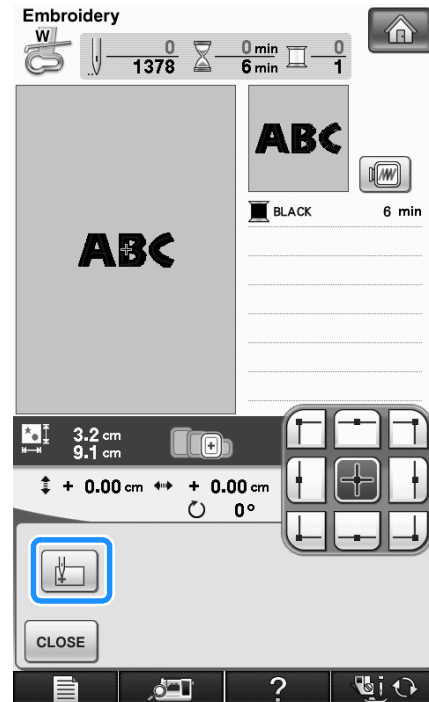

→ The needle is positioned in the lower-left corner of the pattern. The embroidery frame moves so that the needle is positioned correctly.



Note

- To cancel the starting point setting and return the starting point to the center of the pattern, press .
- Use to select a different starting point for embroidering.

4 Press .

5

Embroidery

5 Press .

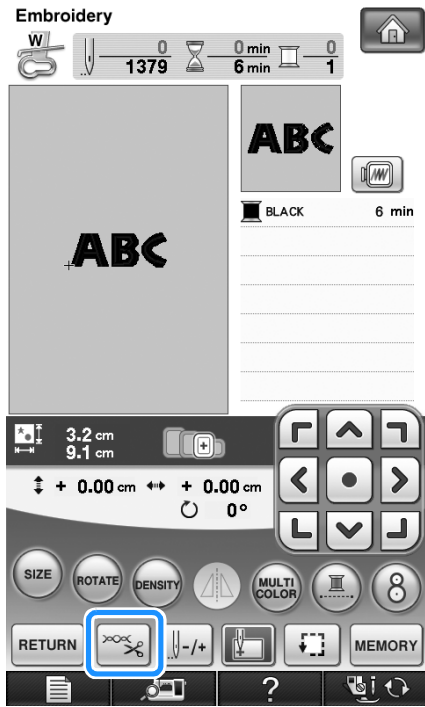

6 Press  to turn off the thread cutting function and then press **CLOSE**.

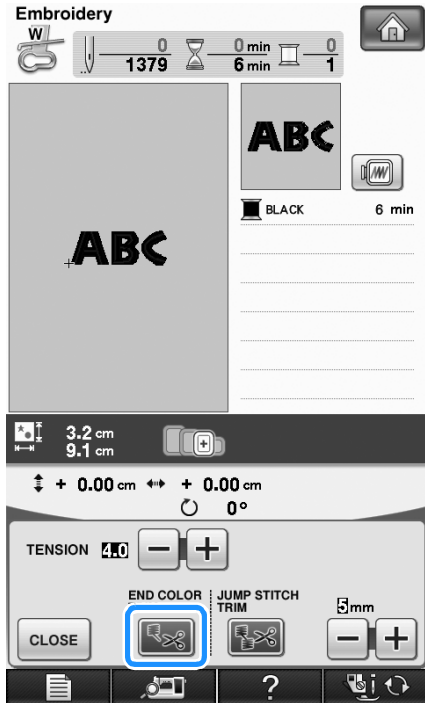

7 Press the "Start/Stop" button.

8 After the characters are embroidered, cut the threads to a generous length, remove the embroidery frame, and then attach the embroidery frame again so that the remaining characters ("DEF") can be embroidered.

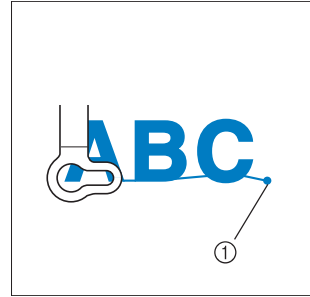

① End of the embroidering

9 As in step ①, select the character patterns for "DEF".

10 Press .

11 Press .

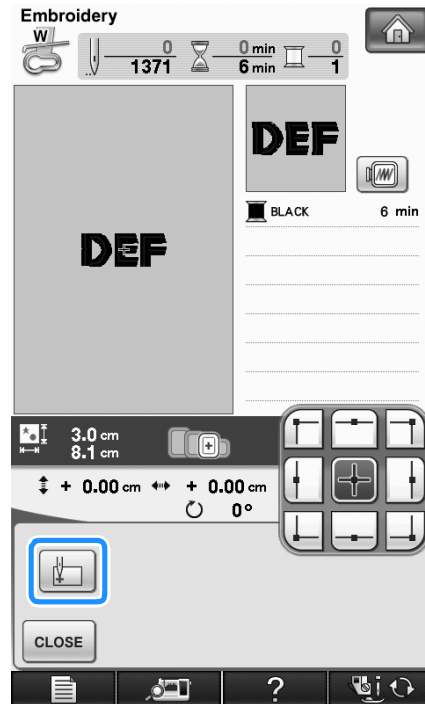

→ The needle is positioned in the lower-left corner of the pattern. The embroidery frame moves so that the needle is positioned correctly.

12 Press **CLOSE**.

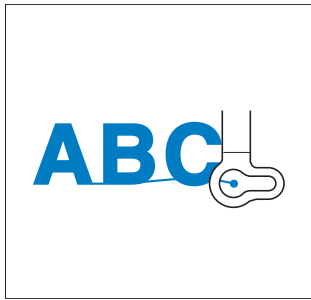

- 13 Use  to align the needle with the end of embroidering for the previous pattern.



- 14 Press the “Start/Stop” button to begin embroidering the remaining character patterns.



Uninterrupted Embroidering (Using a Single Color)

A selected pattern can be stitched out in one color instead of multicolor. The machine will hesitate but not stop between color steps, and then continue till the pattern is completed. Press  for the multicolor steps to become shaded and the selected pattern will embroider in a single color, instead of changing the thread while embroidering. Press  again to return to the pattern’s original settings.

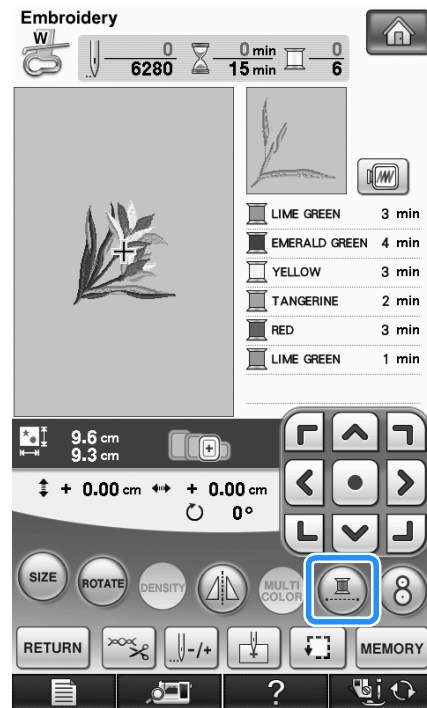

→ The thread color displayed on the screen will be grayed out.

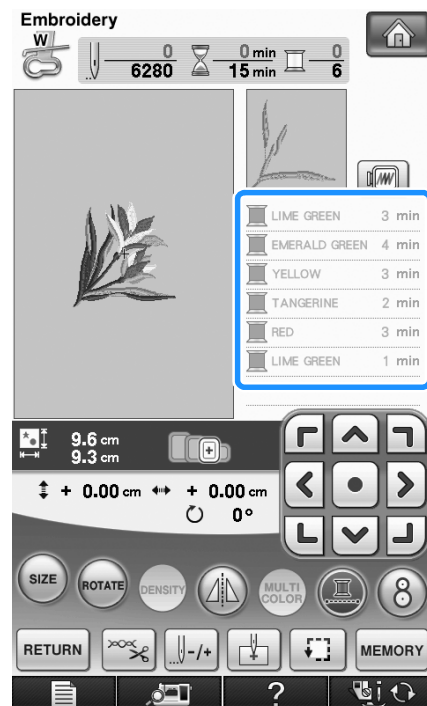

Memo

- Even if uninterrupted embroidering  has been set, the automatic thread cutting function and the thread trimming function can be used (see page 229 and 230).

USING THE MEMORY FUNCTION

Embroidery Data Precautions

Observe the following precautions when using embroidery data other than that created and saved in this machine.

CAUTION

- When using embroidery data other than our original patterns, the thread or needle may break when sewing with a stitch density that is too fine or when sewing three or more overlapping stitches. In that case, use one of our original data design systems to edit the embroidery data.

■ Types of Embroidery Data that can be Used

- Only .pes, .pha, .phb, .phc, and .dst embroidery data files can be used with this machine. Using data other than that saved using our data design systems or sewing machines may cause the embroidery machine to malfunction.

■ Types of USB Devices/Media that can be Used

Stitch data can be saved to or recalled from USB media. Use media that meets the following specifications.

- USB Flash drive (USB Flash memory)
- USB Floppy disk drive

Stitch data can be recalled only.

- USB CD-ROM, CD-R, CD-RW drives

You can also use the following types of USB media with the USB Memory Card Reader/USB card writer module.

- Secure Digital (SD) Card
- CompactFlash
- Memory Stick
- Smart Media
- Multi Media Card (MMC)
- XD-Picture Card



Note

- The processing speed may vary by port selection and quantity of data stored.
- Some USB media may not be usable with this machine. Please visit our website for more details.
- The access lamp will begin blinking after inserting USB devices/media, and it will take about 5 to 6 seconds to recognize the devices/media. (Time will differ depending on the USB device/media).



Memo

- To create file folders, use a computer.
- Letters and numerals can be used in the file names. In addition, if the file name contains no more than eight characters, the entire file name will appear on the screen. If the file name is more than eight characters long, only the first six characters followed by “~” and a number appear as the file name.

■ Computers and Operating Systems with the Following Specifications can be Used

- Compatible models:
IBM PC with a USB port as standard equipment
IBM PC-compatible computer equipped with a USB port as standard equipment
- Compatible operating systems:
Microsoft Windows 2000/XP/Vista

■ Precautions on Using the Computer to Create and Save Data

- If the name of the embroidery data file/folder cannot be identified, for example, because the name contains special characters, the file/folder is not displayed. If this occurs, change the name of the file/folder. We recommend using the 26 letters of the alphabet (uppercase and lowercase), the numbers 0 through 9, "-", and "_".
- If embroidery data larger than 300 mm (H) × 200 mm (W) (approx. 12 inches (H) × 8 inches (W)) is selected, a message is shown asking if you wish to rotate the pattern 90 degrees. Even after being rotated 90 degrees, embroidery data larger than 300 mm (H) × 200 mm (W) (approx. 12 inches (H) × 8 inches (W)) cannot be used. (All designs must be within the 300 mm (H) × 200 mm (W) (approx. 12 inches (H) × 8 inches (W)) design field size.)
- .pes files saved with the number of stitches or the number of colors exceeding the specified limits cannot be displayed. The combined design can not exceed a maximum number of 500,000 stitches or a maximum number of 125 color changes (Above numbers are approximate, depending on the overall size of the design). Use one of our design software programs to edit the embroidery pattern so that it meets these specifications.
- Embroidery data stored in a folder created in USB media can be retrieved.
- Do not create folders in "Removable Disk" on a computer. If embroidery data is stored in a folder in "Removable Disk", that embroidery data cannot be retrieved by the machine.
- Even if the embroidery unit is not attached, the machine will recognize embroidery data.

■ Tajima (.dst) Embroidery Data

- .dst data is displayed in the pattern list screen by file name (the actual image cannot be displayed). Only the first eight characters of the file name can be displayed.
- Since Tajima (.dst) data does not contain specific thread color information, it is displayed with our default thread color sequence. Check the preview and change the thread colors as desired.

■ Trademarks

- Secure Digital (SD) Card is a registered trademark or a trademark of SD Card Association.
- CompactFlash is a registered trademark or a trademark of Sandisk Corporation.
- Memory Stick is a registered trademark or a trademark of Sony Corporation.
- Smart Media is a registered trademark or a trademark of Toshiba Corporation.
- Multi Media Card (MMC) is a registered trademark or a trademark of Infineon Technologies AG.
- xD-Picture Card is a registered trademark or a trademark of Fuji Photo Film Co. Ltd.
- IBM is a registered trademark or a trademark of International Business Machines Corporation.
- Microsoft and Windows are registered trademarks or trademarks of Microsoft Corporation.

Each company whose software title is mentioned in this manual has a Software License Agreement specific to its proprietary programs.

All other brands and product names mentioned in this manual are registered trademarks of their respective companies. However, the explanations for markings such as ® and ™ are not clearly described within the text.

! CAUTION

- Before disconnecting the USB cable, click the “Unplug or Eject Hardware” icon in the taskbar of Windows® 2000 or the “Safely Remove Hardware” icon in the taskbar of Windows® XP/Windows Vista®. Then, when the removable disk can safely be removed, disconnect the USB cable from the computer and the machine.

Windows® XP



Windows Vista®



Saving Embroidery Patterns in the Machine’s Memory

You can save embroidery patterns that you have customized and will use often; for example, your name, patterns that have been rotated or had the size changed, patterns that have had the sewing position changed, etc. A total of about 2 MB of patterns can be saved in the machine's memory.



Note

- Do not turn the main power to OFF while the “Saving” screen is displayed. You will lose the pattern you are saving.



Memo

- It takes a few seconds to save a pattern to the machine’s memory.
- See page 251 for information on retrieving a saved pattern.

- 1 Press **MEMORY** when the pattern you want to save is in the sewing screen.

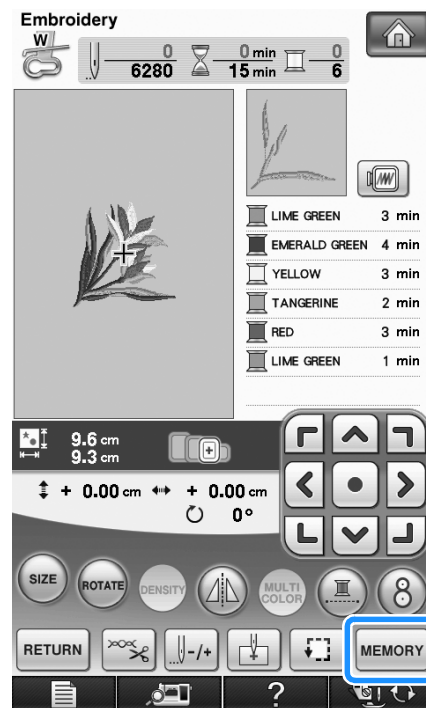

2 Press .

- * Press **CLOSE** to return to the original screen without saving.

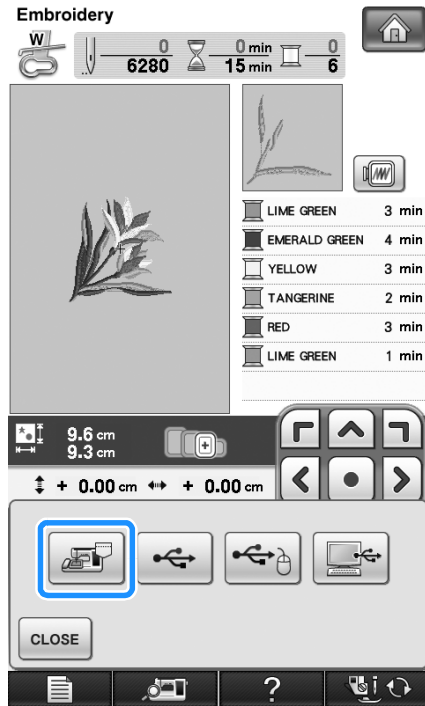

→ The “Saving” screen is displayed. When the pattern is saved, the display returns to the original screen automatically.

■ If the Memory is Full

If the screen below displays, either the maximum number of patterns have been saved or the pattern you want to save takes a lot of memory, and the machine cannot save it. If you delete a previously saved pattern, you can save the current pattern.

1 Press **DELETE**.

- * Press **CANCEL** to return to the original screen without saving.

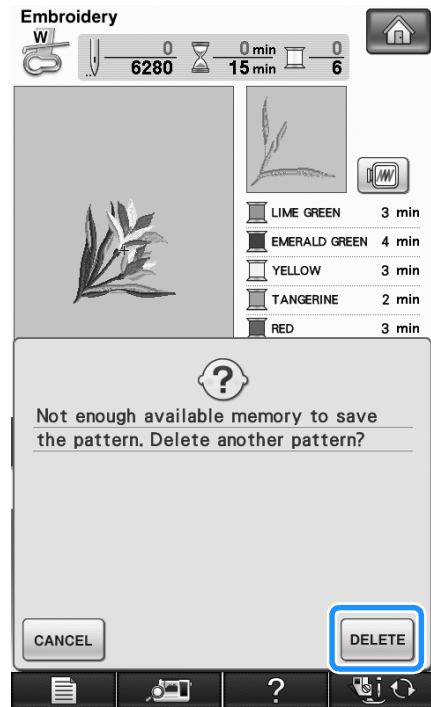

→ The machine displays the patterns currently saved.

2 Select the pattern you want to delete.

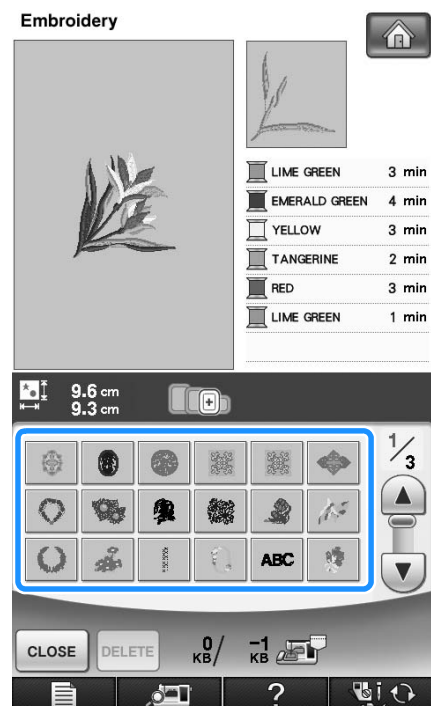

3 Press **DELETE**.

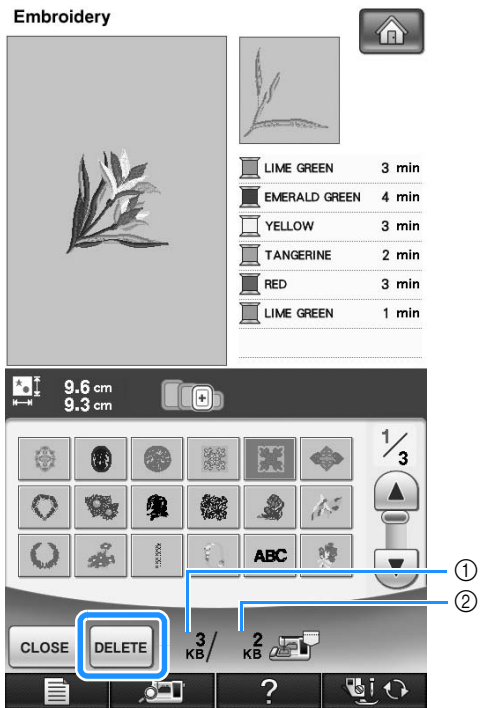

- ① Amount of memory used by the pattern to be deleted
- ② Amount of memory needed to save the current pattern

4 Press **OK**.

* If you decide not to delete the pattern, press

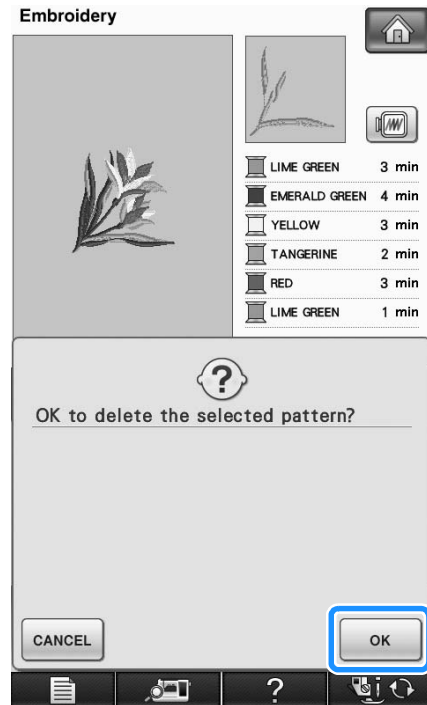

→ The “Saving” screen displays. When the pattern is saved, the display returns to the original screen automatically.



Note

- Do not turn the main power to OFF while the “Saving” screen is displayed. You will lose the pattern you are saving.



Memo

- If there is enough memory available after deleting the pattern, the pattern you want to save will be saved automatically. If there is not enough memory available after deleting the pattern, repeat the steps above to delete another pattern from the machine’s memory.
- It takes a few seconds to save a pattern.
- See page 251 for more information about retrieving saved patterns.

Saving Embroidery Patterns to USB Media

When sending embroidery patterns from the machine to USB media, plug the USB media into the machine's USB port.

Memo

- USB media is commercially available, but some USB media may not be usable with this machine. Please visit our website for more details.
- Depending on the type of USB media being used, either directly plug the USB device into the machine's USB port or plug the USB media Reader/Writer into the machine's USB port.
- The USB media can be inserted or removed at any time.

- 1 Press **MEMORY** when the pattern you want to save is in the sewing screen.

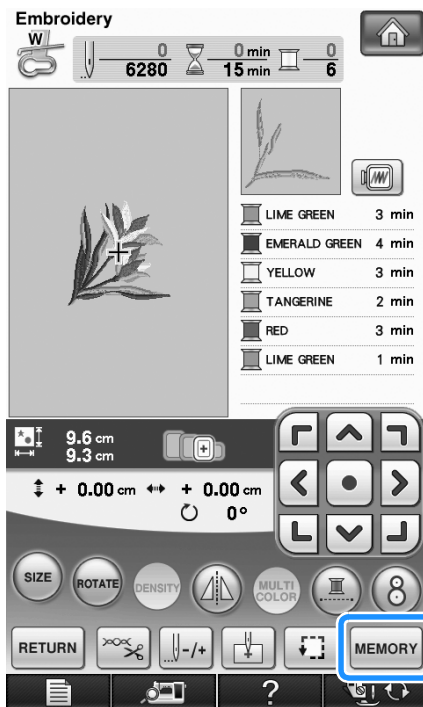

- 2 Insert the USB media into the primary (top) USB port on the machine.

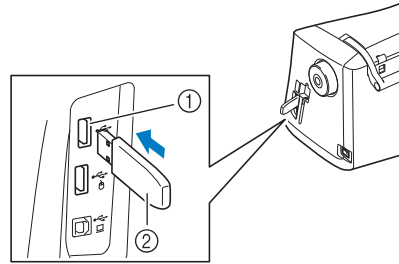

- 1 Primary (top) USB port for media
- 2 USB media

Note

- The processing speed may vary by port selection and quantity of data. The primary (top) USB port processes the data faster than the center port. It is recommended to use the primary (top) USB port.
- Two USB media cannot be used with this machine at the same time. If two USB media are inserted, only the USB media inserted first is detected.
- Do not insert anything other than USB media into the USB media port. Otherwise, the USB media drive may be damaged.

5

Embroidery

3 Press .

* Press **CLOSE** to return to the original screen without saving.

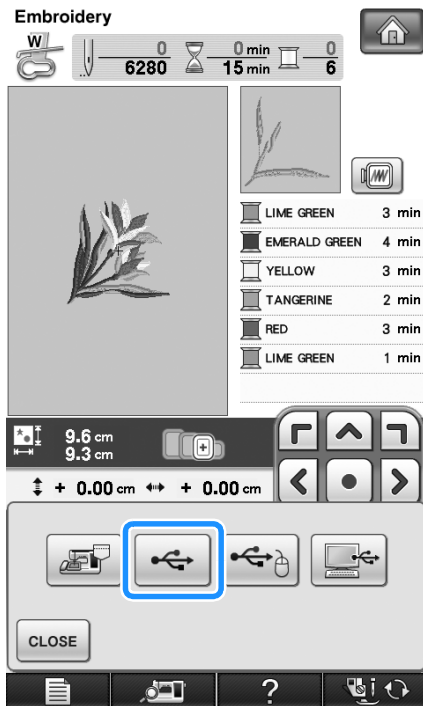

→ The “Saving” screen is displayed. When the pattern is saved, the display returns to the original screen automatically.



Note

- Do not insert or remove USB media while “Saving” screen is displayed. You will lose some or all of the pattern you are saving.

Saving Embroidery Patterns in the Computer

Using the included USB cable, the machine can be connected to your computer, and the embroidery patterns can be temporarily retrieved from and saved in the “Removable Disk” folder in your computer. A total of about 3 MB of embroidery patterns can be saved in the “Removable disk”, but the saved embroidery patterns are deleted when the machine is turned OFF.



Note

- Do not turn the main power to OFF while the “Saving” screen is displayed. You will lose the pattern you are saving.

- 1** Plug the USB cable connector into the corresponding USB ports for the computer and for the machine.
- 2** Turn on your computer and select “Computer (My computer)”.

* The USB cable can be plugged into the USB ports on the computer and embroidery machine whether or not they are turned on.

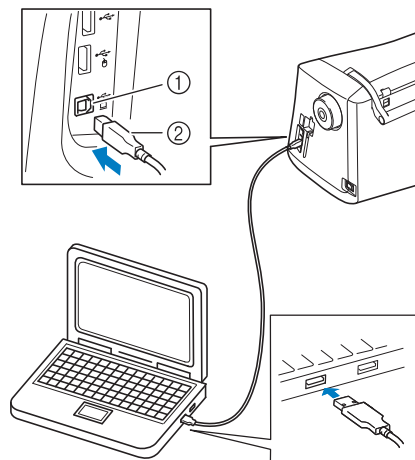

- ① USB port for computer
- ② USB cable connector

→ The “Removable Disk” icon will appear in “Computer (My computer)” on the computer.



Note

- The connectors on the USB cable can only be inserted into a port in one direction. If it is difficult to insert the connector, do not insert it with force. Check the orientation of the connector.
- For details on the position of the USB port on the computer (or USB hub), refer to the instruction manual for the corresponding equipment.

- 3 Press **MEMORY** when the pattern you want to save is in the sewing screen.

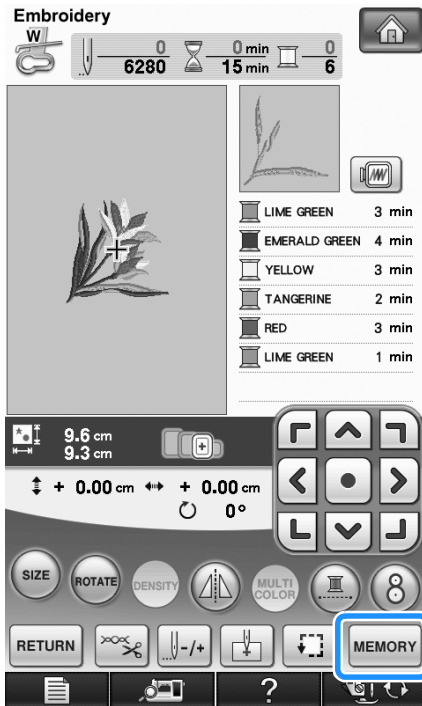

- 4 Press .

* Press **CLOSE** to return to the original screen without saving.

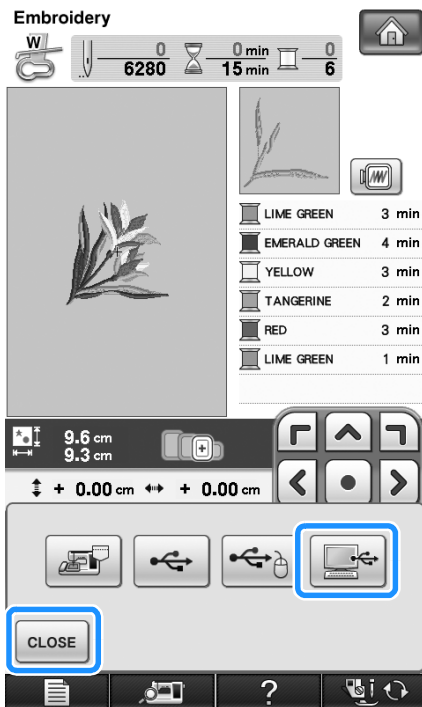

→ The pattern will be temporarily saved to "Removable Disk" under "Computer (My computer)".

- 5 Select the pattern's .phc file in "Removable Disk" and copy the file to the computer.

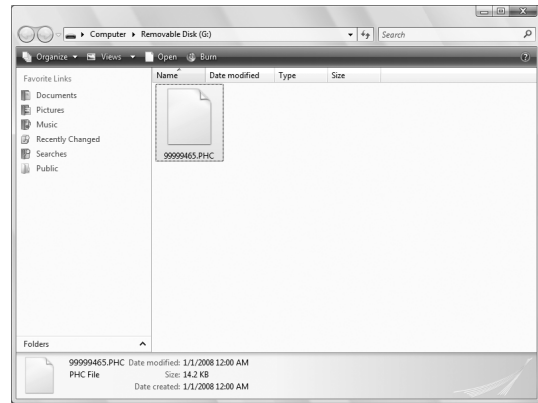

Retrieving Patterns from the Machine's Memory

- 1 Press .



→ The machine displays the patterns currently in the memory.

2 Press the key of the pattern you want to retrieve.

* Press **CLOSE** to return to the original screen.

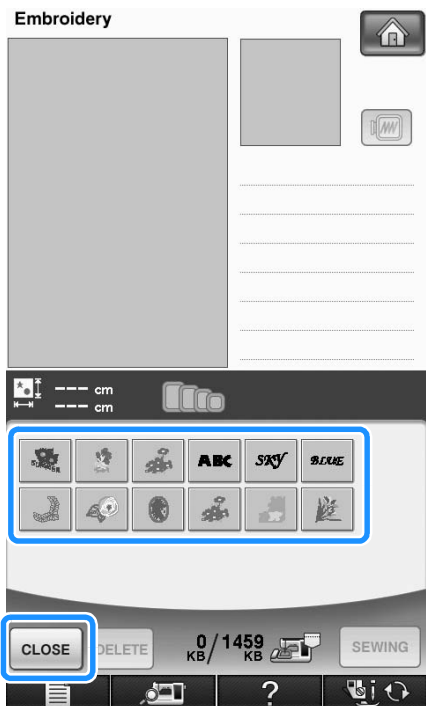

3 Press **SEWING**.

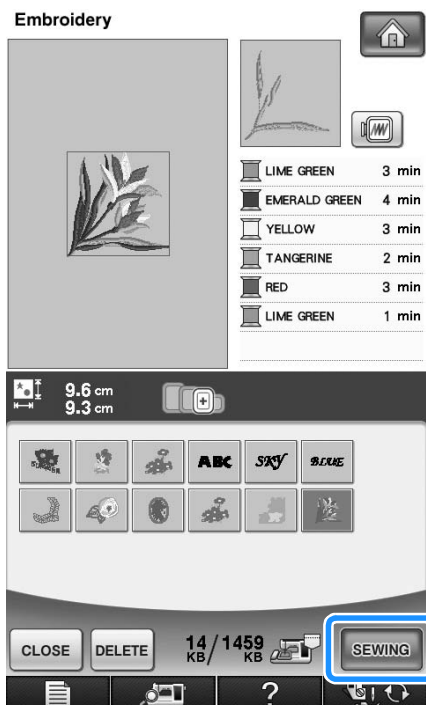

→ The sewing screen is displayed.

Recalling from USB Media

You can recall a specific embroidery pattern from either direct USB media or a folder in the USB media. If the pattern is in a folder, check each folder to find the embroidery pattern.



Note

- The processing speed may vary by port selection and quantity of data.

1 Insert the USB media into the primary (top) USB port on the machine (see page 249).

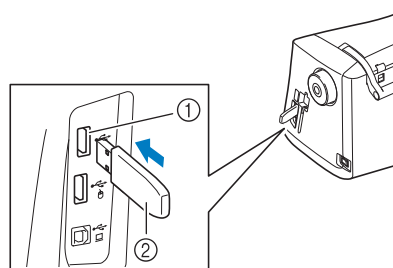

- ① Primary (top) USB port for media
- ② USB media

2 Press .

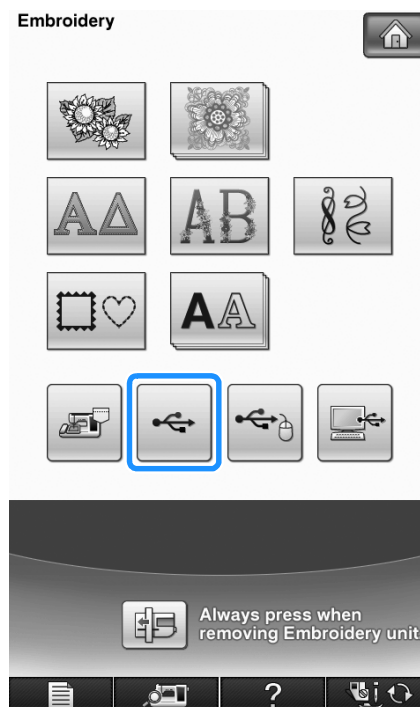

→ Embroidery patterns and a folder in a top folder are displayed.

3 Press  when there is a subfolder to sort two or more stitch patterns to USB media, the embroidery pattern in the subfolder is displayed.

* Press **CLOSE** to return to the original screen without recalling.

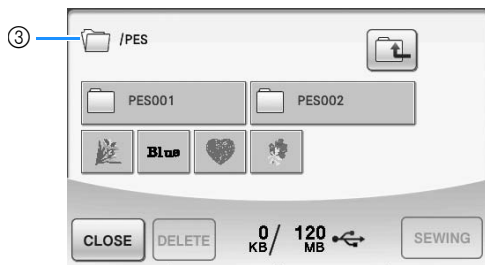
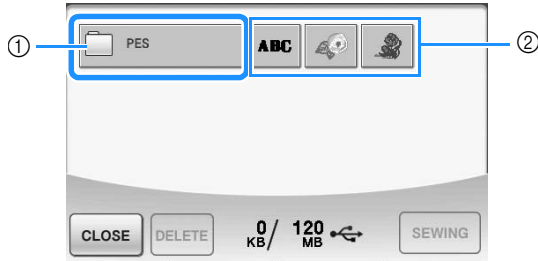

- ① Folder name
- ② Embroidery patterns in USB media
- ③ Path
- * The path to shows the current folder at the top of the list. Embroidery patterns and subfolders within a folder are displayed.
- * Press  to return to the previous folder.
- * Use the computer to create folders. Folders cannot be created with the machine.

4 Press the key of the pattern you want to retrieve.

* Press **CLOSE** to return to the original screen.

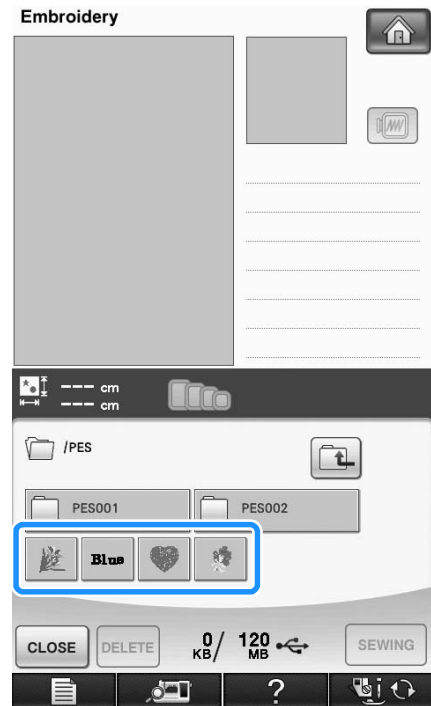

5 Press **SEWING**.

* Press **DELETE** to delete the pattern. The pattern will be deleted from the USB media.

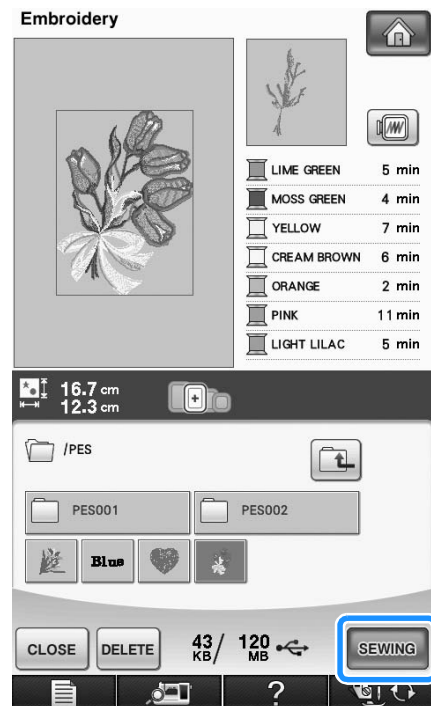

→ The sewing screen is displayed.

Recalling from the Computer

- 1 Plug the USB cable connector into the corresponding USB ports for the computer and for the machine (see page 250).
- 2 On the computer, open "Computer (My computer)" then go to "Removable Disk".

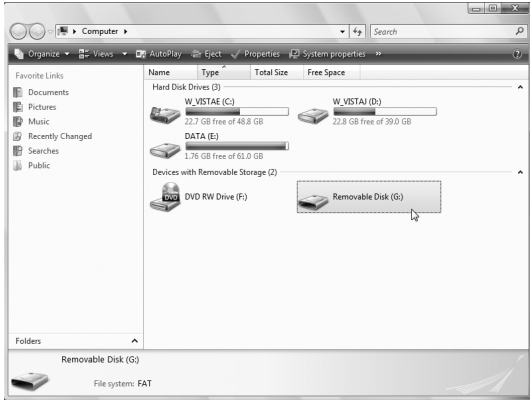

- 3 Move/copy the pattern data to "Removable Disk".

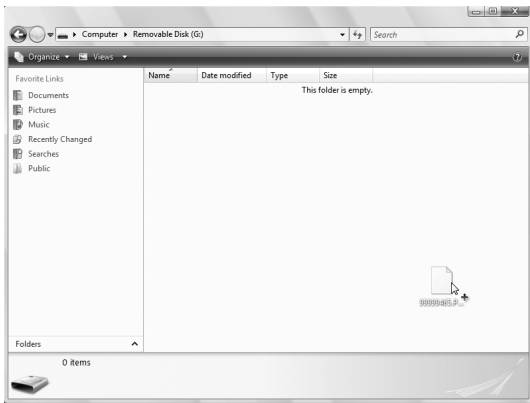

→ Pattern data in "Removable Disk" is written to the machine.



Note

- While data is being written, do not disconnect the USB cable.
- Do not create folders within "Removable Disk". Since folders are not displayed, stitch pattern data within folders cannot be recalled.

- 4 Press  .



→ The patterns in the computer are displayed on the selection screen.

- 5 Press the key of the pattern you want to recall.

* Press **CLOSE** to return to the original screen.

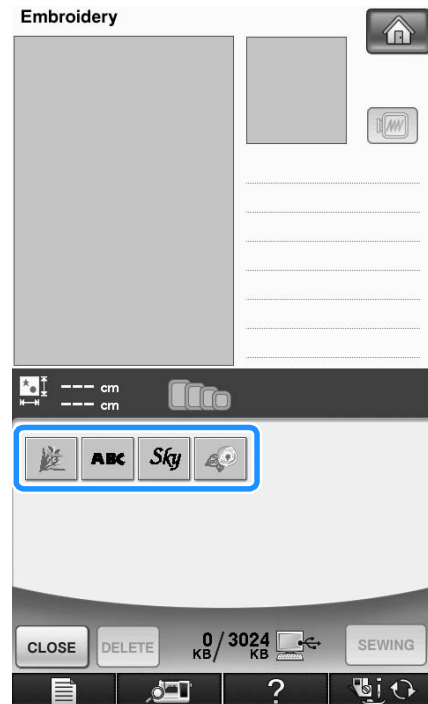

6 Press **SEWING** .

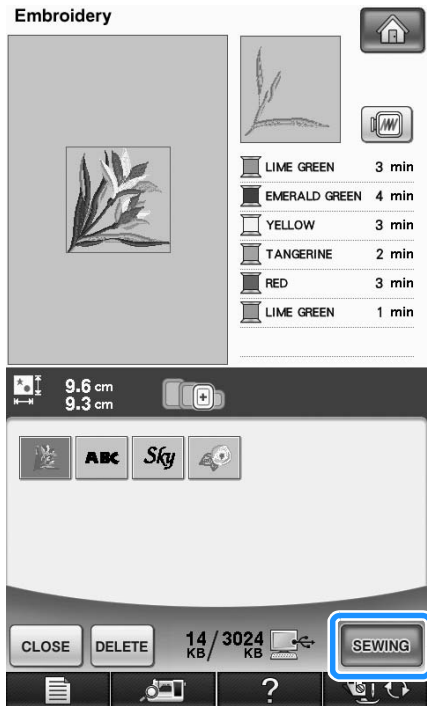

→ The sewing screen is displayed.

5

Embroidery

EMBROIDERY APPLICATIONS

Using a Frame Pattern to Make an Appliqué (1)

You can use framed patterns of the same size and shape to create an appliqué. Embroider one pattern with a straight stitch and one pattern with a satin stitch.

- 1 Select a straight stitch frame pattern. Embroider the pattern onto the appliqué material, then cut neatly around the outside of the shape.

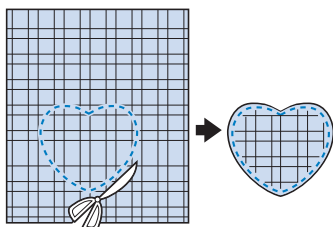
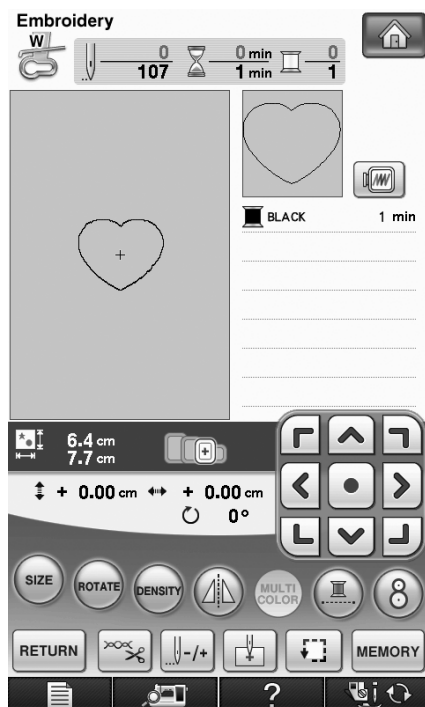

- 2 Embroider the same pattern from step 1 onto the base fabric.

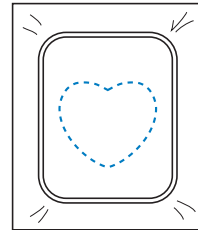

- 3 Apply a thin layer of fabric glue or a temporary spray adhesive to the rear of the appliqué created in step 1. Attach the appliqué to the base fabric matching the shapes.

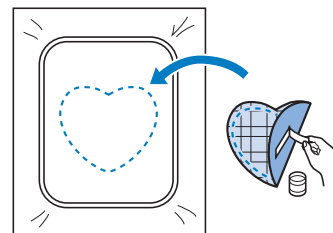

- 4** Select the satin stitch frame pattern of the same shape as the appliqué. Embroider over the appliqué and base fabric from step **3** to create the appliqué.

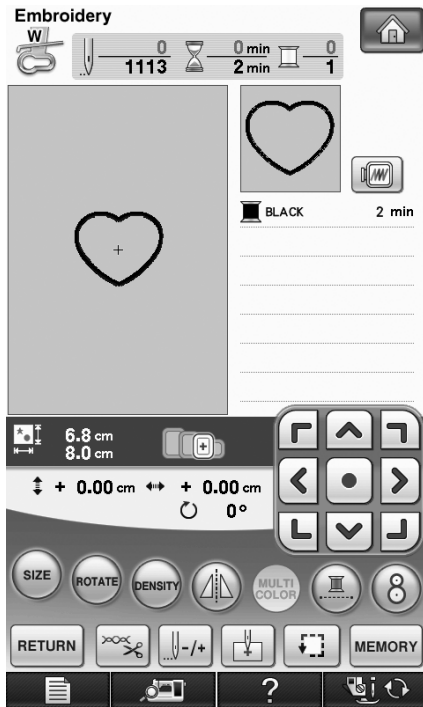
**Note**

- If you change the size or position of the patterns when selecting them, make a note of the size and location.

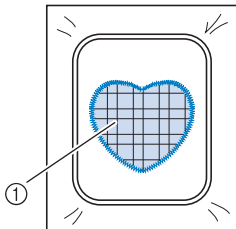

① Appliqué material

Using a Frame Pattern to Make an Appliqué (2)

This is a second method to make appliqué using embroidery patterns. You do not have to change the fabric in the embroidery frame using this method. Embroider one pattern with a straight stitch and one pattern with a satin stitch.

- 1** Select a straight stitch frame pattern, and embroider the pattern onto the base fabric.

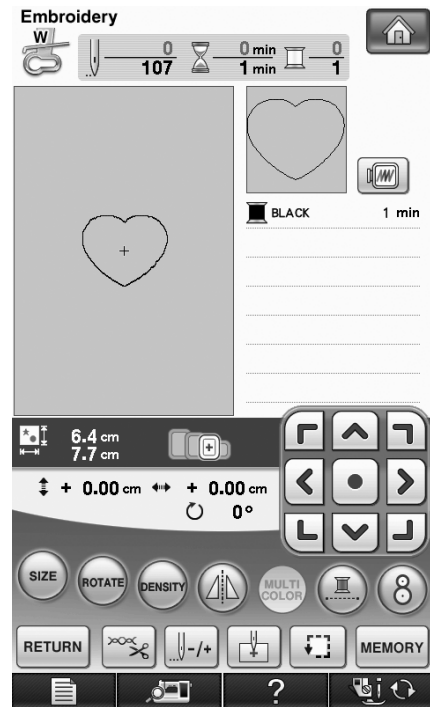

- 2** Place the appliqué fabric over the pattern embroidered in step **1**.

- * Be sure that the appliqué fabric completely covers the seam.

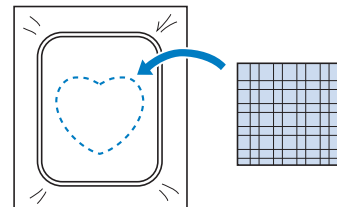

- 3** Embroider the same pattern on the appliqué fabric.

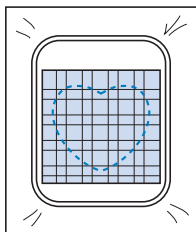

- 4** Remove the embroidery frame from the embroidery unit, and cut around the outside of the stitches.

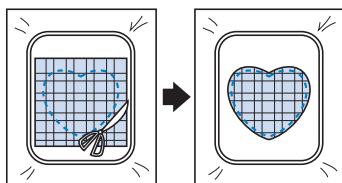

Note

- Do not remove the fabric from the embroidery frame to cut it. Also, do not pull strongly on the fabric. Otherwise, the fabric may loosen in the frame.

- 5** Select the satin stitch frame pattern of the same shape as the appliqué.

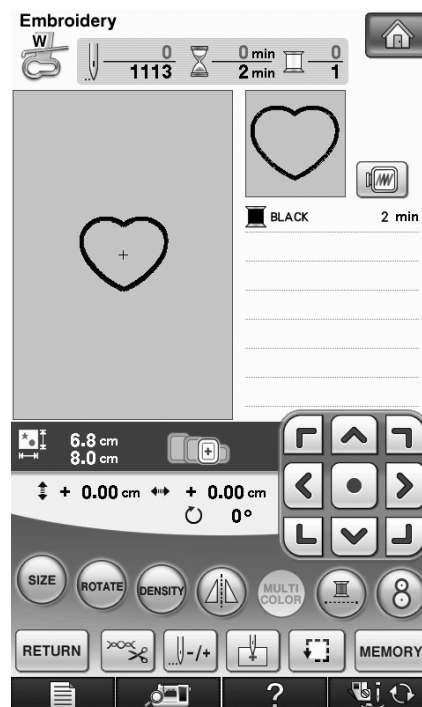

Note

- Do not change the size or position of the pattern.
- If you change the size or position of the patterns when selecting them, make a note of the size and location.

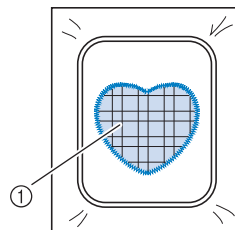

① Appliqué material

- 6** Reattach the embroidery frame to the embroidery unit, and embroider the satin stitch pattern to create an appliqué.

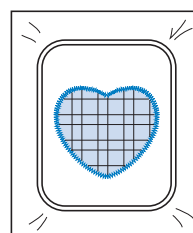

Sewing Split Embroidery Patterns

Split embroidery patterns created with PE-DESIGN Ver.7 or later can be sewn. With split embroidery patterns, embroidery designs larger than the embroidery hoop are divided into multiple sections, which combine to create a single pattern after each section is sewn.

For details on creating split embroidery patterns and for more detailed sewing instructions, refer to the operation manual included with PE-DESIGN Ver.7 or later.

The following procedure describes how to read the split embroidery pattern shown below from USB media and embroider it.

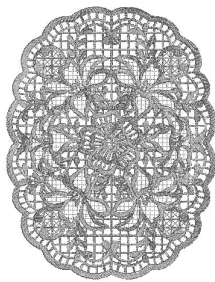

1 Connect to the machine the media containing the created split embroidery pattern, and then select the split embroidery pattern to be embroidered.

- * For details on recalling patterns, refer to "Selecting Patterns from Embroidery Cards" on page 194, "Recalling from USB Media" on page 252, or "Recalling from the Computer" on page 254.

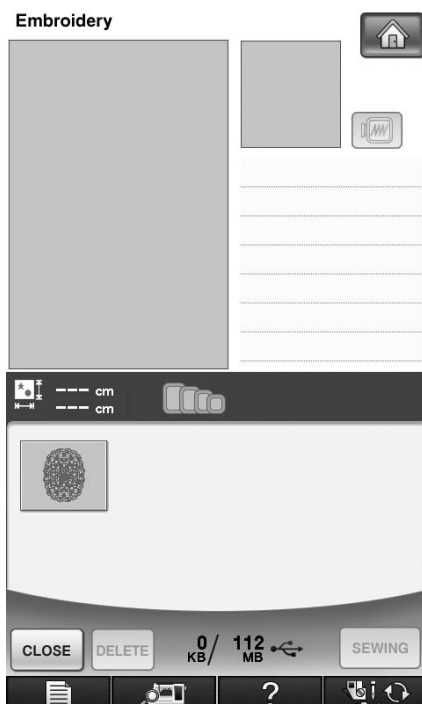

→ A screen appears so that a section of the split embroidery pattern can be selected.

2 Select section **Aa** to be embroidered.

- * Select the sections in alphabetical order.
- * A maximum of 12 sections can be displayed in one page. If there are 13 or more sections in the pattern, press or to display the previous or next page.

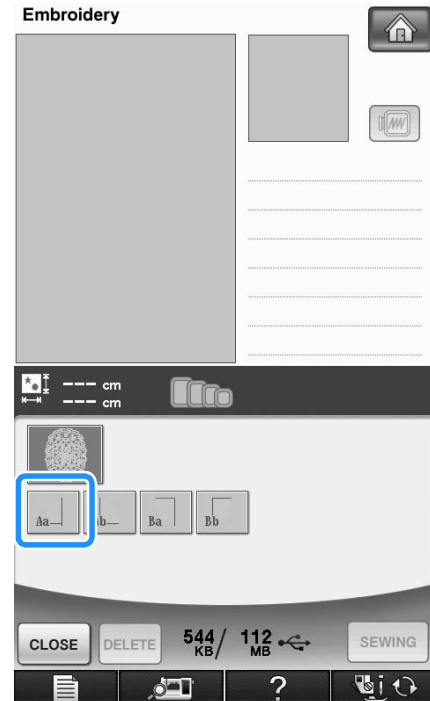

3 Press **SEWING**.

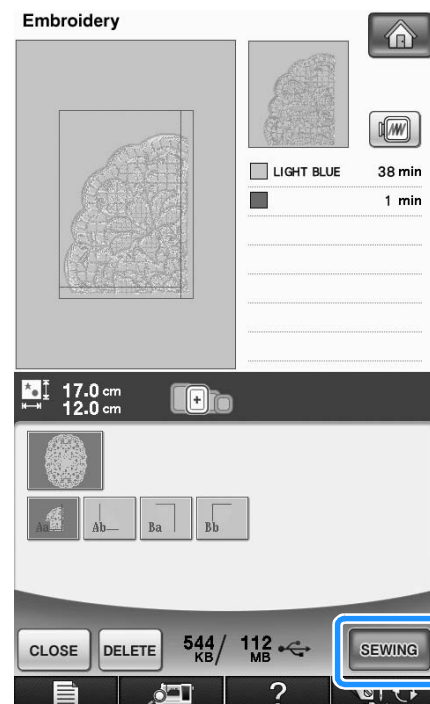

4 If necessary, edit the pattern.

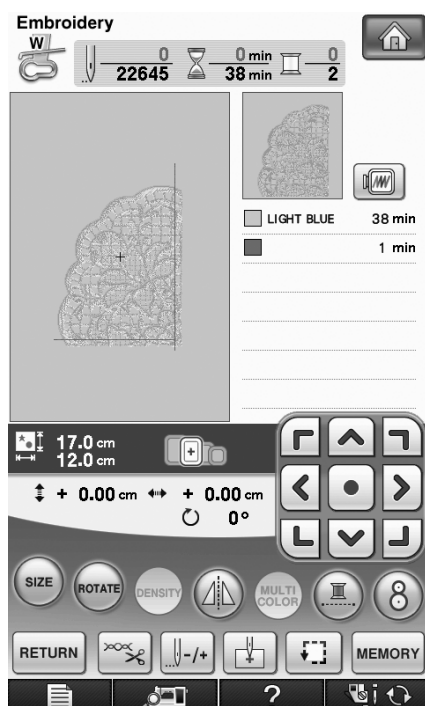

* For details, refer to “REVISING THE PATTERN” on page 234.



Memo

- The pattern can be rotated 90° to either the left or right when  is pressed.

5 Press the “Start/Stop” button to embroider the pattern section.

6 When embroidering is finished, the following screen appears. Press .

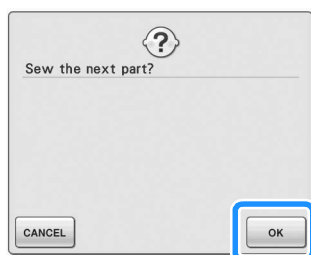

→ A screen appears so that a section of the split embroidery pattern can be selected.

7 Repeat steps 2 through 6 to embroider the remaining sections of the pattern.



Chapter 6

Embroidery Edit

EXPLANATION OF FUNCTIONS.....	262
SELECTING PATTERNS TO EDIT	263
Selecting Embroidery Patterns/Brother "Exclusives"/Greek Alphabet Patterns/Floral Alphabet Patterns/Utility Embroidery Patterns/Frame Patterns.....	264
Selecting Alphabet Character Patterns.....	264
EDITING PATTERNS.....	267
■ Key Functions.....	268
Moving the Pattern	269
Rotating the Pattern.....	269
Changing the Size of the Pattern.....	270
Deleting the Pattern.....	271
Changing the Configuration of Alphabet Character Patterns.....	271
Changing Alphabet Character Spacing.....	272
Reducing Character Spacing.....	273
Separating Combined Character Patterns	274
Changing the Color of Each Alphabet Character in a Pattern	275
Embroidering Linked Characters.....	276
Changing the Thread Color.....	278
Creating a Custom Thread Table.....	279
■ Adding a Color to the Custom Thread Table from the List	282
Choosing a Color from the Custom Thread Table	283
Designing Repeated Patterns	284
■ Sewing Repeated Patterns	284
■ Repeating One Element of a Repeated Pattern	286
■ Color Sorting Repeated Patterns.....	287
■ Assigning Thread Marks.....	289
Duplicating a Pattern.....	290
After Editing.....	290
COMBINING PATTERNS.....	291
Editing Combined Patterns.....	291
■ Selecting combined embroidery patterns	293
Sewing Combined Patterns	294
VARIOUS EMBROIDERING FUNCTIONS	295
Uninterrupted Embroidering (Using a Single Color)	295
Basting Embroidery.....	295
Creating an Appliqué Piece.....	296
■ Creating an Appliqué Piece	296
■ Using a Frame Pattern for the Outline	300
Using the Built-In Camera to Align the Embroidering Position	302
USING THE MEMORY FUNCTION	305
PRINT AND STITCH (COMBINING EMBROIDERY PATTERNS AND PRINTED DESIGNS).....	306
Selecting a Pattern.....	307
■ Checking Only the Embroidery Pattern.....	307
Outputting the Background Image and Positioning Image	308
■ Using USB Media	308
■ Using a USB Cable	309
Printing the Background and Embroidery Position Sheet	310
Sewing Embroidery Patterns	310

EXPLANATION OF FUNCTIONS

With the Embroidery Edit functions, you can combine embroidery patterns and character patterns, change the size of patterns, rotate patterns, and perform many other editing functions. This machine can perform the 9 functions listed below.

■ Print and Stitch (Combining Embroidery Patterns and Printed Designs)

You can create beautiful three-dimensional embroidered designs by ironing a background onto fabric or printing it onto printable fabric, then sewing complementary embroidery on top of the background.

■ Create Appliqué Piece

You can create an appliqué piece from the built-in patterns and patterns on embroidery cards.

■ Combine Patterns

You can easily create combinations of embroidery patterns, frame patterns, character patterns, patterns from the machine's memory, patterns from separately sold embroidery cards, and many other patterns.

■ Move Patterns

Within the 30 cm × 20 cm (approx. 12 inches × 8 inches) wide embroidery area, you can change the position of patterns, and check the position on the LCD.

■ Rotate Patterns

You can rotate patterns one degree, ten degrees or ninety degrees at a time.

■ Enlarge or Reduce Patterns

You can make patterns larger or smaller.

- This function is not available for some patterns.

■ Create Mirror Images

You can create horizontal mirror images.

- This function is not available for some patterns.

■ Change Alphabet Character Spacing

You can increase or decrease the spacing between characters in combined patterns.

■ Change Alphabet Character Appearance/Layout

You can change the layout of the characters to a curved line, diagonal, etc. There are 6 choices total.

■ Change the Thread Colors of Patterns

You can change the thread colors of the pattern to your favorite colors.

■ Creating a Repeating Pattern

You can add copies of a pattern to create a pattern that repeats in a vertical or horizontal direction.



SELECTING PATTERNS TO EDIT

Prepare the machine for embroidery according to the instructions on page 182, and press , then

 to display the screen below.

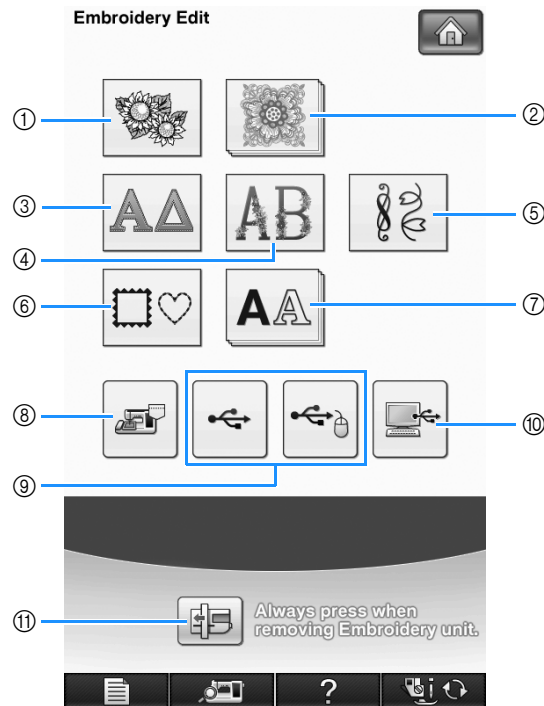

- ① Embroidery patterns
- ② Brother "Exclusives"
- ③ Greek alphabet patterns
- ④ Floral alphabet patterns
- ⑤ Utility embroidery patterns
- ⑥ Frame patterns
- ⑦ Alphabet characters
- ⑧ Patterns saved in the machine's memory (see page 251)
- ⑨ Patterns saved in USB media (see page 252)
- ⑩ Patterns saved on the computer (see page 254)
- ⑪ Press this key to position the embroidery unit for storage.





Memo

- See page 187 for more information on each category's selection screen.



Note

- You can also sew Utility Stitches or Character/Decorative Stitches with the embroidery unit attached by pressing  and  (a confirmation message for moving the carriage will appear). Attach the appropriate presser foot before sewing.

Selecting Embroidery Patterns/ Brother “Exclusives”/Greek Alphabet Patterns/Floral Alphabet Patterns/Utility Embroidery Patterns/Frame Patterns

- 1 Select the category of the pattern.
- 2 Press the key of the pattern you want to edit.
 - * See pages 189 and 192 for more information on selecting patterns.
 - The pattern is displayed in the top part of the screen.
- 3 Press **SET**.

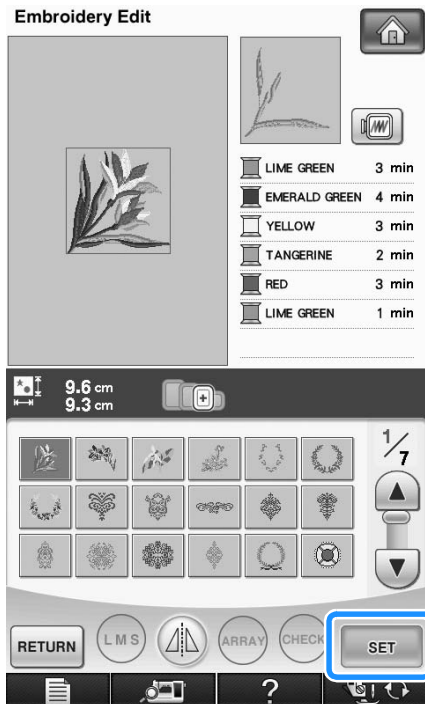

→ The pattern selected for editing is outlined in red on the embroidery edit display.

- 4 Proceed to “EDITING PATTERNS” on page 267 to edit the pattern.

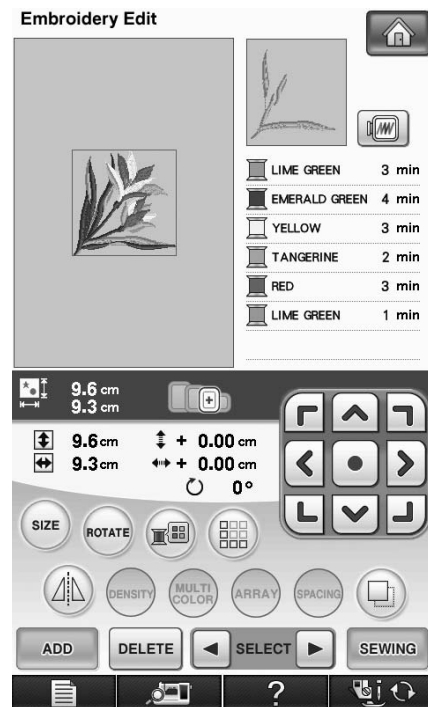

Selecting Alphabet Character Patterns

When you select character patterns from the embroidery edit screen, you can edit the appearance of the pattern at the same time.

- 1 Press **AA**.

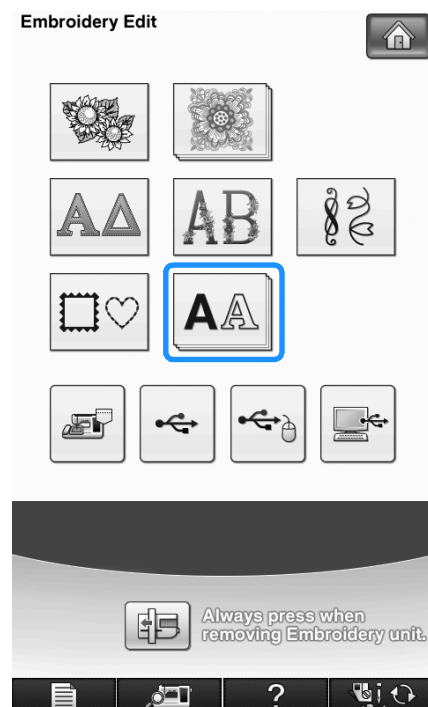

2 Select the font, then enter the characters.
(Example: A B C D)

* See page 190 for more information about selecting characters.

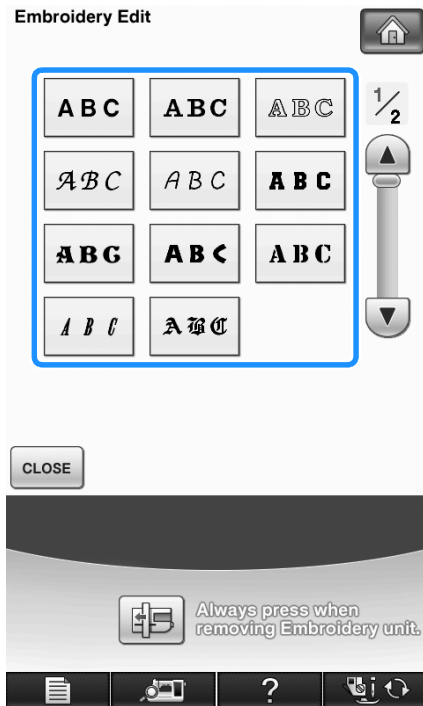

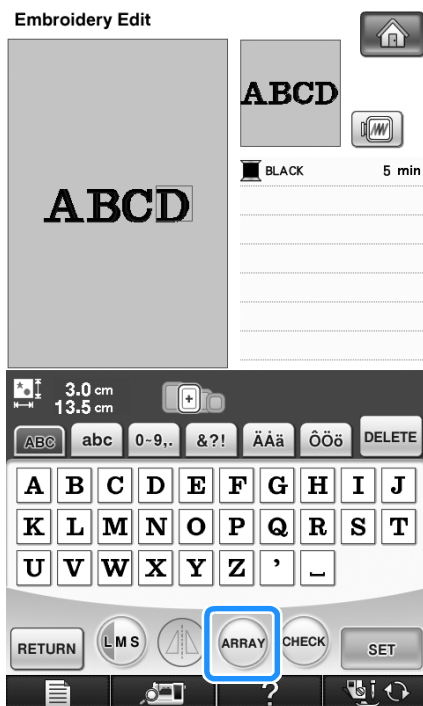

3 Press **ARRAY** to change the layout of the pattern.

* If the characters are too small to see, press **CHECK** to view a display of all entered characters.







4 Select the layout. (Example: )

When selecting an arc, use  and  to change the degree of the arc.

* Press  to make the arc flatter.

* Press  to make the arc rounder.

Memo

- When selecting ,  and  change to  and . You can increase or decrease the incline.

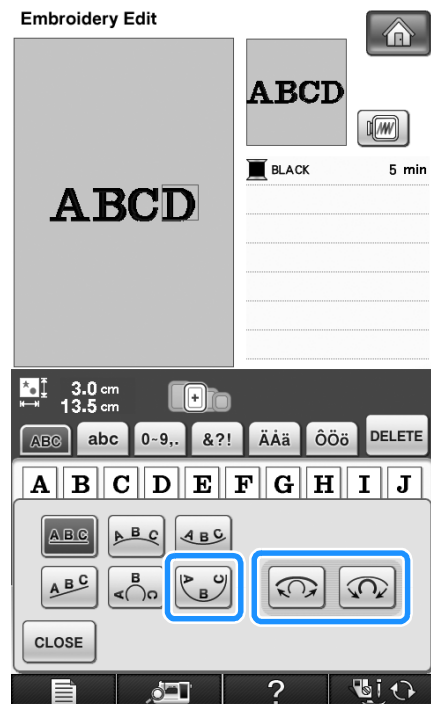

5 Press **CLOSE** to return to the original screen.

6 After you finish your selections, press

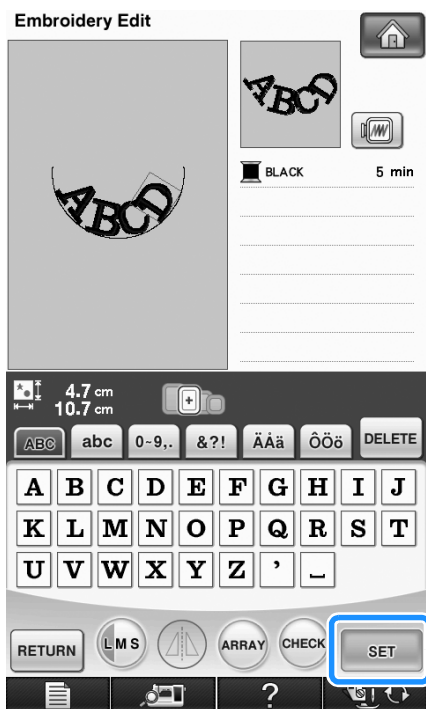

→ The embroidery edit screen will appear.

7 Proceed to “EDITING PATTERNS” on page 267 to edit the pattern.

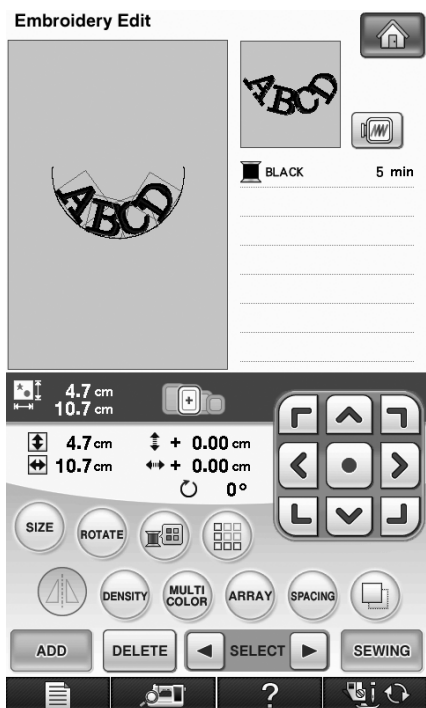

EDITING PATTERNS

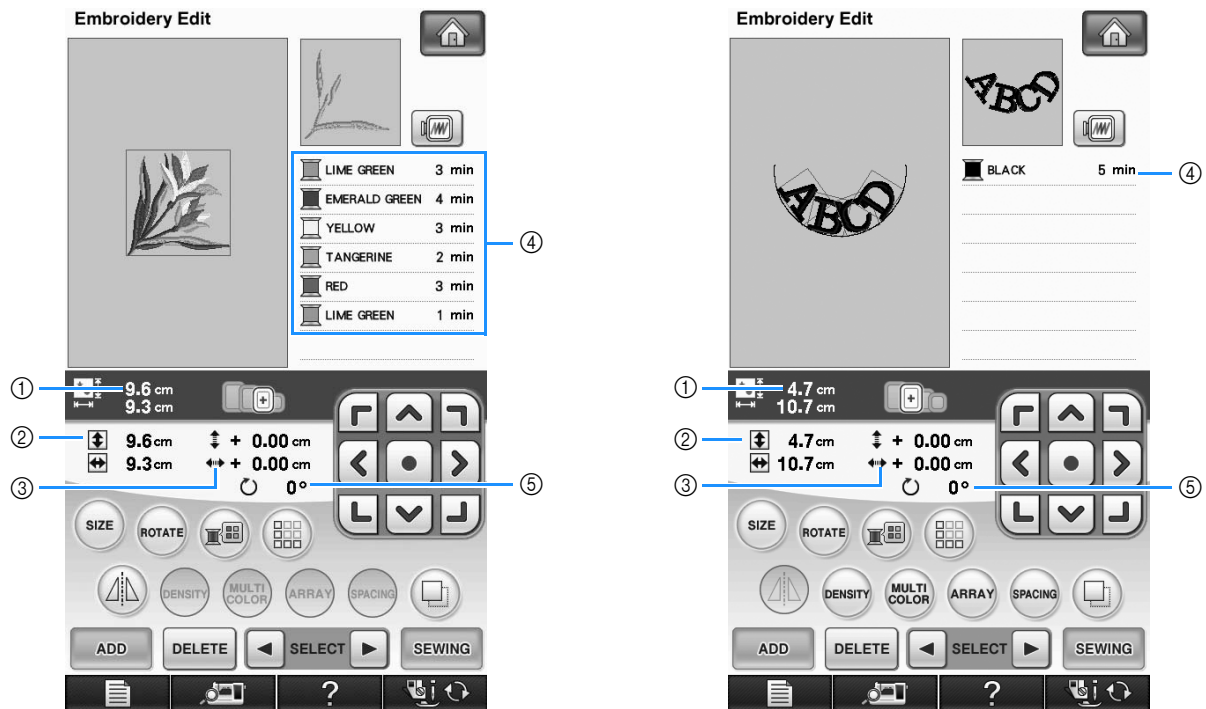

- ① Shows the size of the entire combined pattern.
- ② Shows the size of the pattern currently selected.
- ③ Shows the distance from the center of the frame.
- ④ Shows the color sequence and times of each step of the pattern currently selected.
- ⑤ Shows the degree of rotation for the pattern.

Memo

- If a key display is light gray, you cannot use that function with the selected pattern.

■ Key Functions

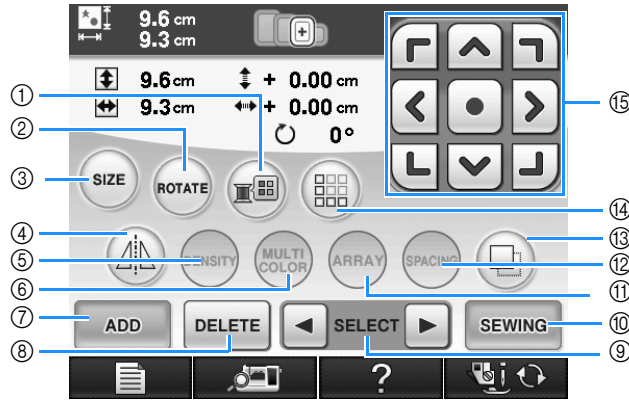

No.	Display	Key Name	Explanation	Page
①		Thread palette key	Press this key to change the colors of the displayed pattern.	278
②		Rotate key	Press this key to rotate the pattern. You can rotate a pattern one degree, ten degrees or ninety degrees at a time.	269
③		Size key	Press this key to change the size of the pattern. Patterns can be enlarged or reduced.	270
④		Horizontal mirror image key	Press this key to make a horizontal mirror image of the selected pattern.	238
⑤		Density key	Press this key to change the density of frame patterns or character patterns.	239
⑥		Multi color key	Press this key to change the color of individual characters in a pattern.	275
⑦		Add key	Press this key to add another pattern to the editing pattern.	290
⑧		Delete key	Press this key to delete the selected pattern (the pattern outlined by the red box).	271
⑨		Pattern select key	When a combined pattern is selected, use these keys to select a part of the pattern to edit.	—
⑩		Sewing key	Press this key to call up the sewing screen.	290
⑪		Array key	Press this key to change the configuration of a character pattern.	271
⑫		Character spacing key	Press this key to change the spacing of character patterns.	272
⑬		Duplicate key	Press this key to duplicate a pattern.	290
⑭		Border key	Press this key to make and edit a repeating pattern.	284
⑮		Arrow keys (Center key)	Press these keys to move the pattern in the direction indicated by the arrow on the key. (Press to return the pattern to its original position.)	269

Moving the Pattern

Press  to move the pattern in the direction shown on the key.

Press  to return the pattern to the center.

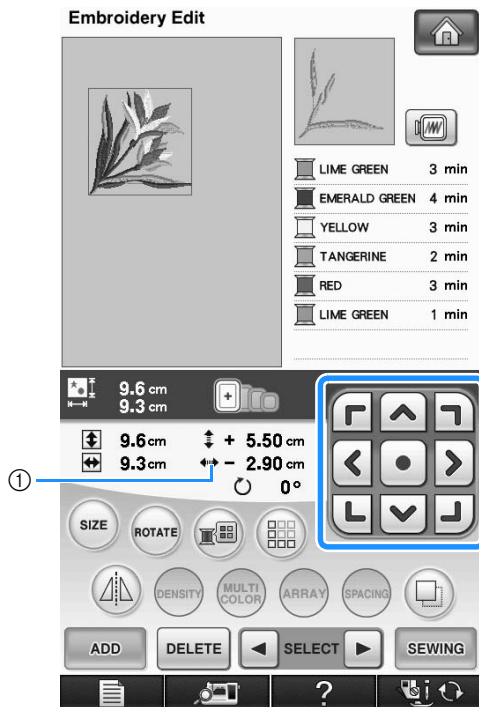

① Distance from the center

The pattern can also be moved by dragging it. If a USB mouse is connected, move the mouse to position the pointer on the desired pattern, and then select and drag the pattern. The pattern can also be dragged by selecting it directly in the screen with your finger or the touch pen.

Rotating the Pattern

1 Press .

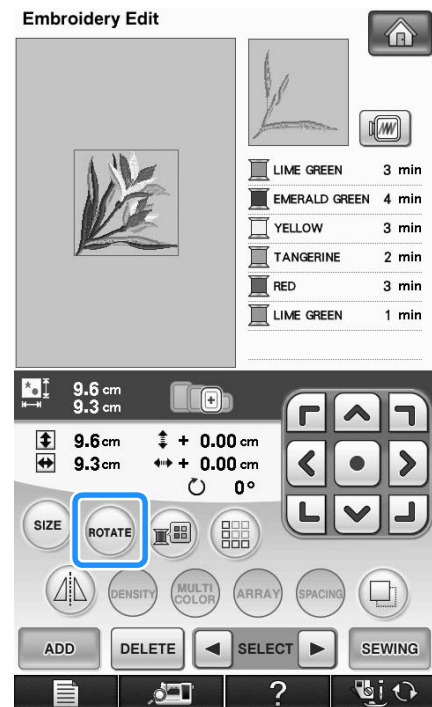

2 Select the angle by which the pattern is rotated.

- * Press to rotate the pattern 90 degrees to the left.
- * Press to rotate the pattern 90 degrees to the right.
- * Press to rotate the pattern 10 degrees to the left.
- * Press to rotate the pattern 10 degrees to the right.
- * Press to rotate the pattern 1 degree to the left.
- * Press to rotate the pattern 1 degree to the right.
- * Press **RESET** to return the pattern to its original position.

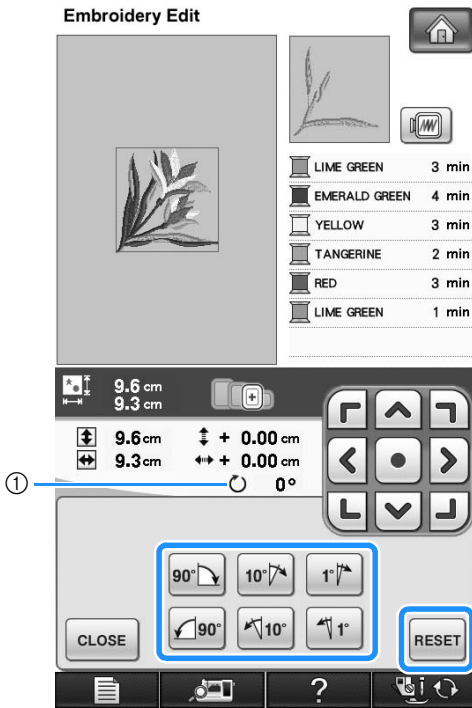

① Degree of the pattern's rotation

3 Press **CLOSE** to return to the original screen.

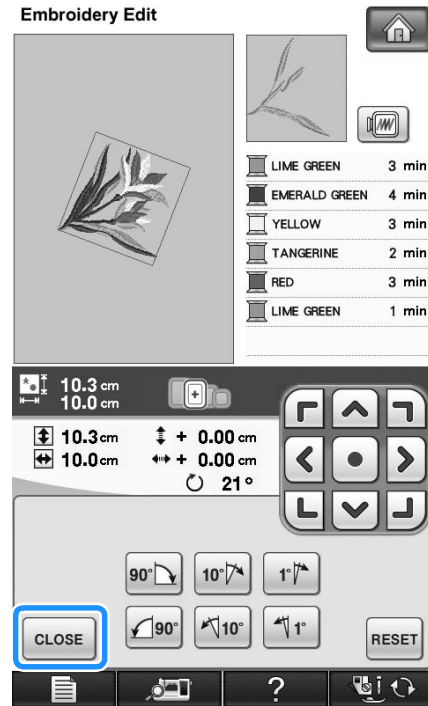

Changing the Size of the Pattern

1 Press **SIZE**.

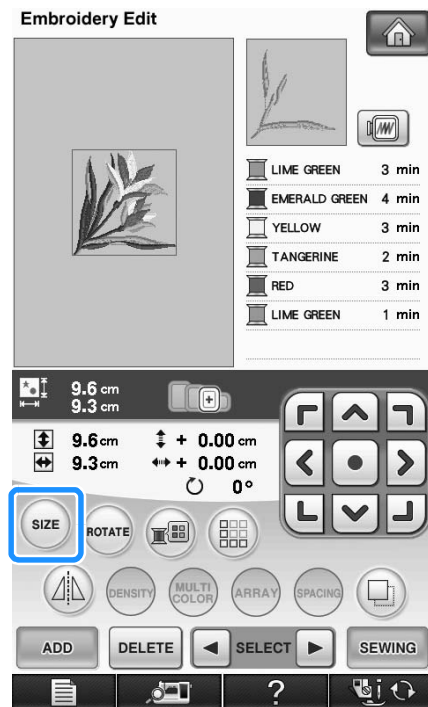

2 Select the direction in which to change the size.

- * Press to enlarge the pattern proportionately.
- * Press to shrink the pattern proportionately.
- * Press to stretch the pattern horizontally.
- * Press to compact the pattern horizontally.
- * Press to stretch the pattern vertically.
- * Press to compact the pattern vertically.
- * Press to return the pattern to its original appearance.

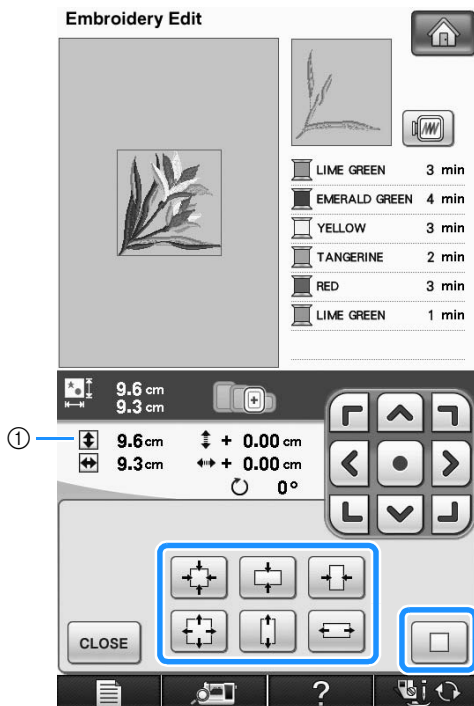

① Shows the size of the pattern being edited.

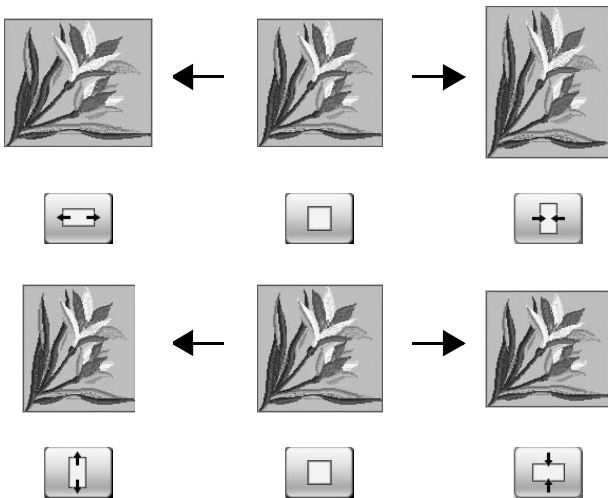

3 Press to return to the original screen.

Deleting the Pattern

Press to delete the pattern from the screen.

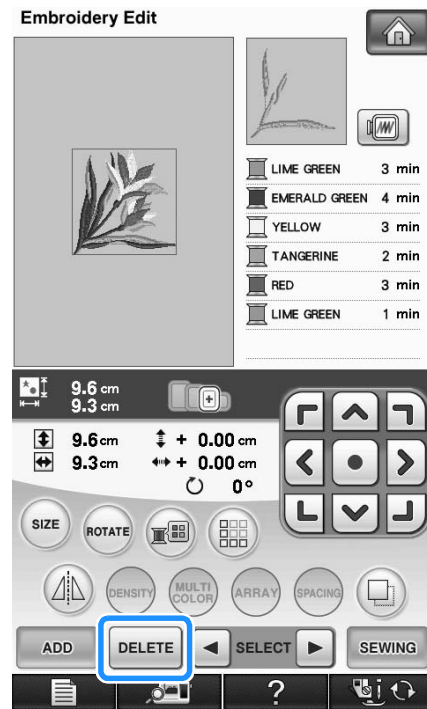

Changing the Configuration of Alphabet Character Patterns

1 Press .

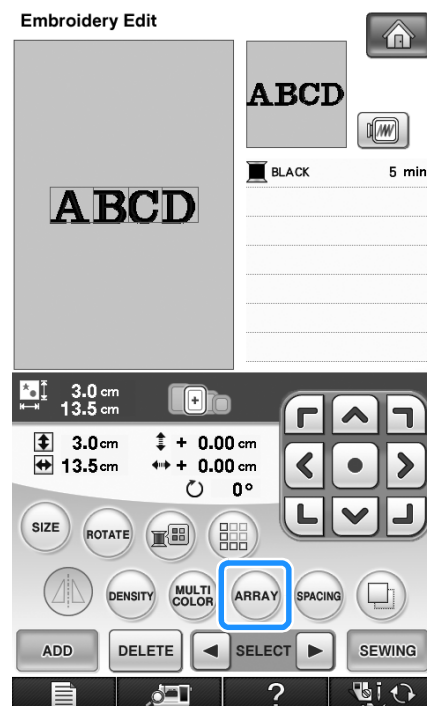

2 Press the key of the layout you want to embroider.

* See page 265 for more information about layout types.

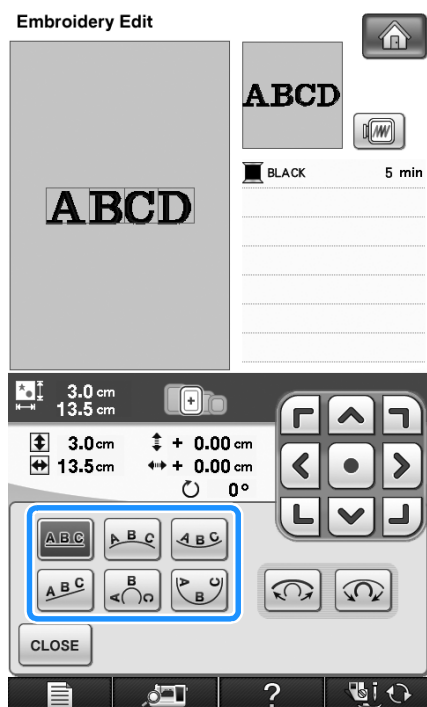



→ The display will show the selected layout.

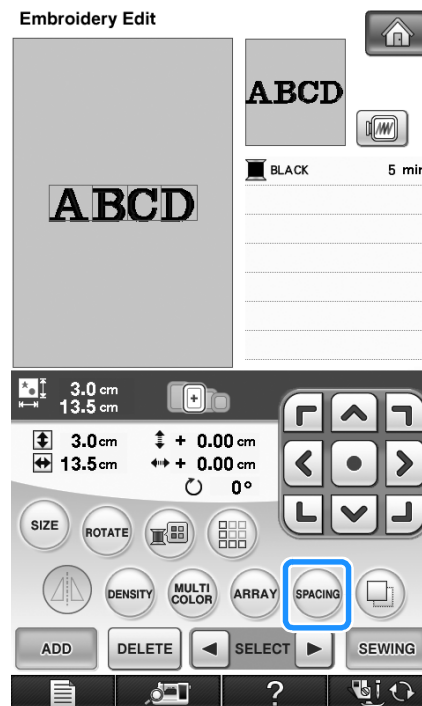

3 Press **CLOSE**.

Changing Alphabet Character Spacing

1 Press **SPACING**.



2 Use  to change the spacing.

- * Press  to increase the character spacing.
- * Press  to decrease the character spacing.
- * Press  to return the pattern to its original appearance.

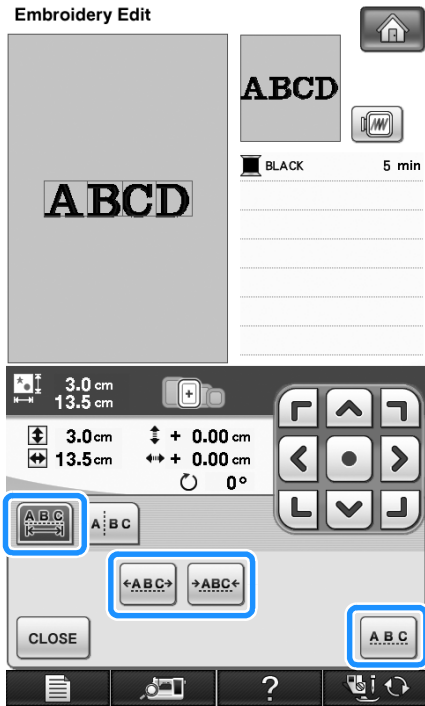

A B C D ↔ ABCD



3 Press  to return to the original screen.

Reducing Character Spacing

The spacing between characters can be reduced to 50% of the narrowest character in the group.

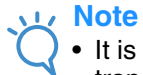

Note

- It is not recommended to edit data and transfer to other or older version machines. Same features do not apply in other machines, so problems may occur.
- Character spacing can be reduced only when characters are arranged normally on a straight line.

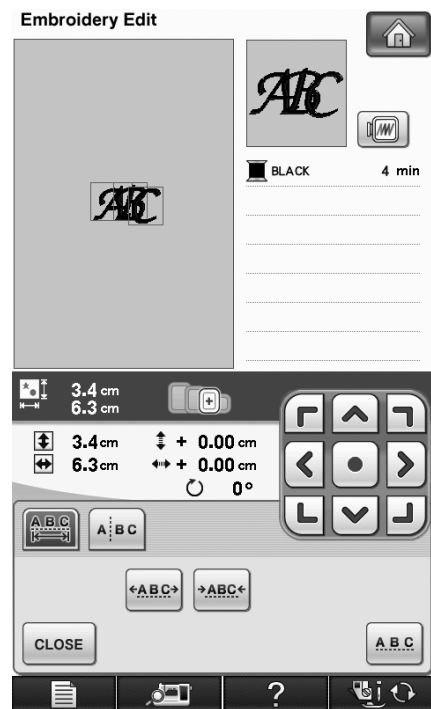
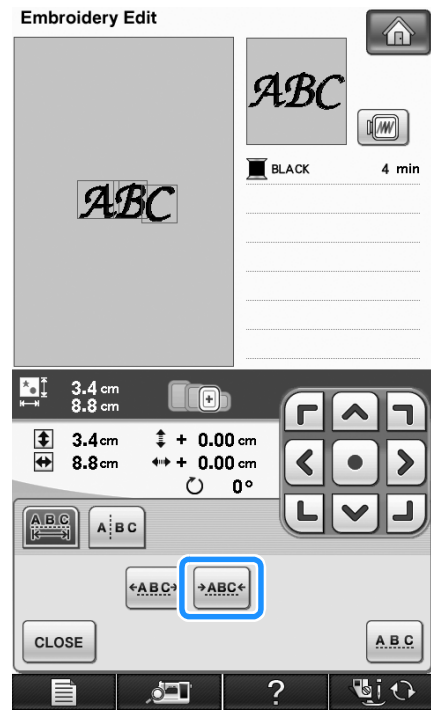

Separating Combined Character Patterns

Combined character patterns can be separated to adjust the character spacing or to separately edit the patterns after all characters have been entered.

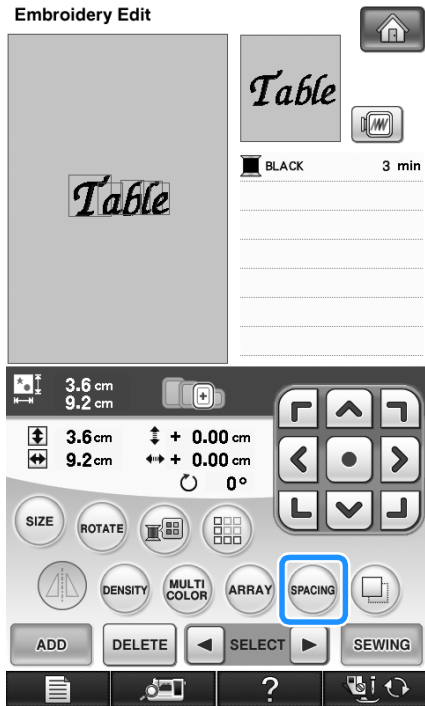

1 Press .

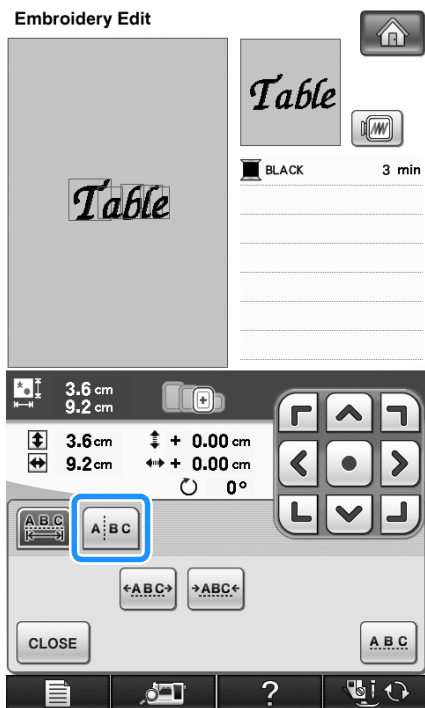

2 Press .



→ The key appears as .

3 Use   to select where the pattern is to be separated, and then press  to separate it. For this example, the pattern will be separated between "T" and "a".

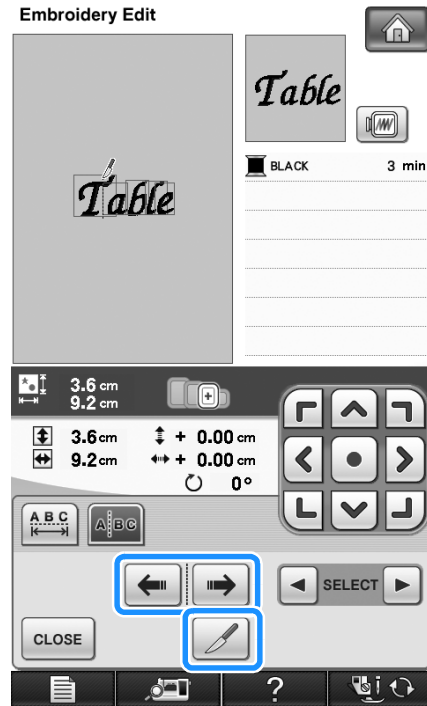

Note

- A separated character pattern cannot be combined again.

- 4 Use **SELECT** to select a pattern, and then use the arrow keys to adjust the character spacing.

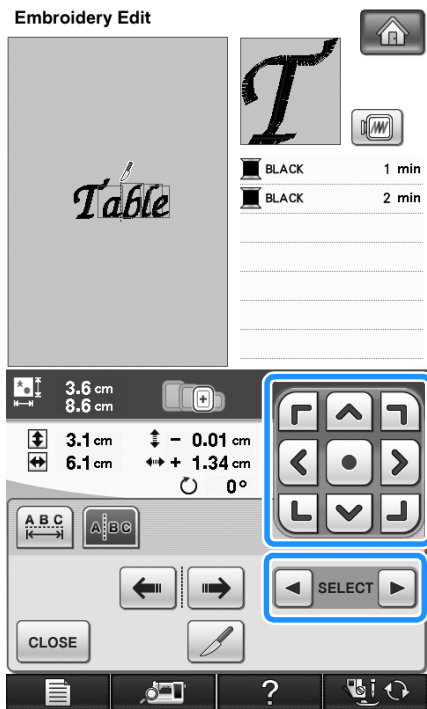

- 5 Press **CLOSE**.

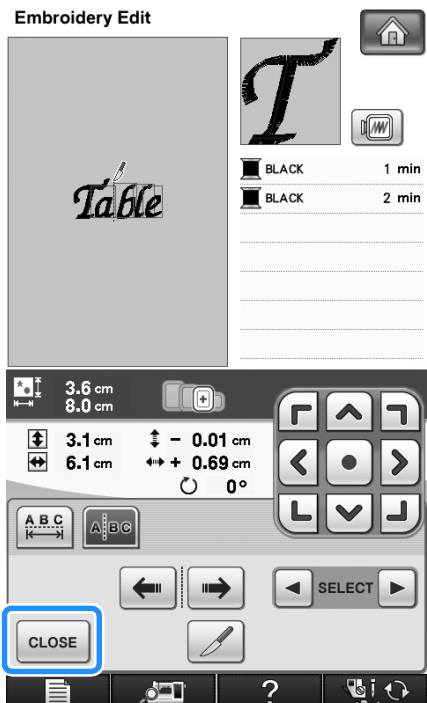

Changing the Color of Each Alphabet Character in a Pattern

- 1 Press **MULTI COLOR** so you can assign a thread color to each character.

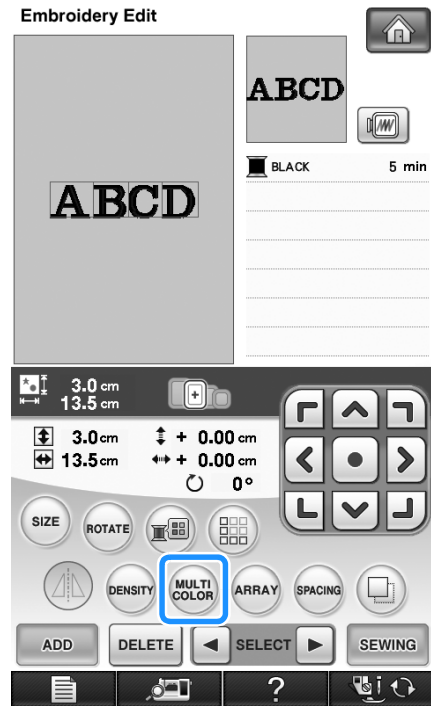

- 2 Change the thread to sew each character in a different color.

* Press **GRID** to change the colors in the sewing order.

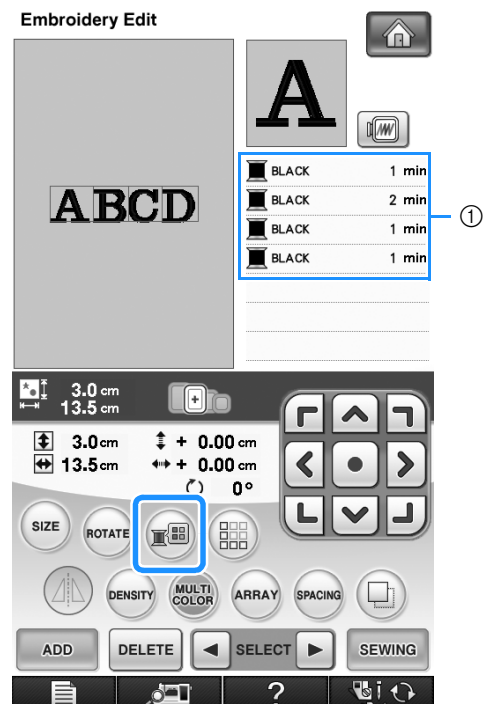

① Color for each character

Embroidering Linked Characters

Follow the procedure described below to embroider linked characters in a single row when the pattern extends beyond the embroidery frame.

Example: Linking “DEF” to the characters “ABC”

A B C D E F

1 Select the character patterns for “ABC”.



Note

- For details on selecting character patterns, refer to “Selecting Alphabet Character Patterns” on page 264.

2 In the sewing screen, press .

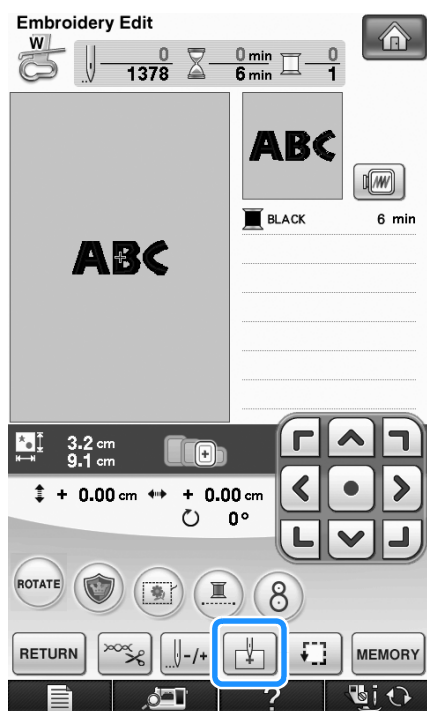

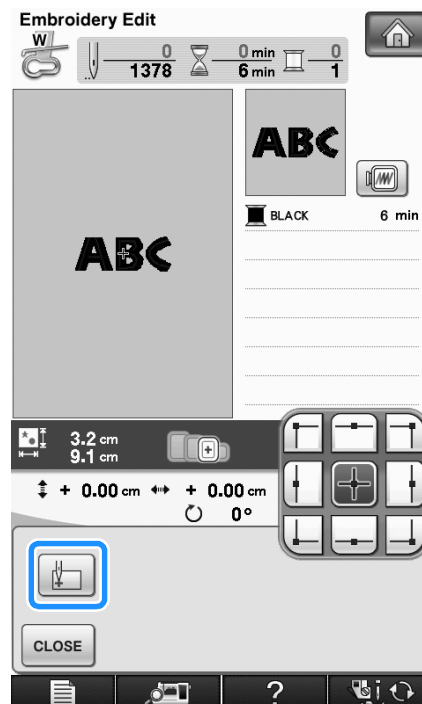

3 Press .



→ The needle is positioned in the lower-left corner of the pattern. The embroidery frame moves so that the needle is positioned correctly.





Note

- To cancel the starting point setting and return the starting point to the center of the pattern, press .
- Use  to select a different starting point for embroidering.

4 Press .

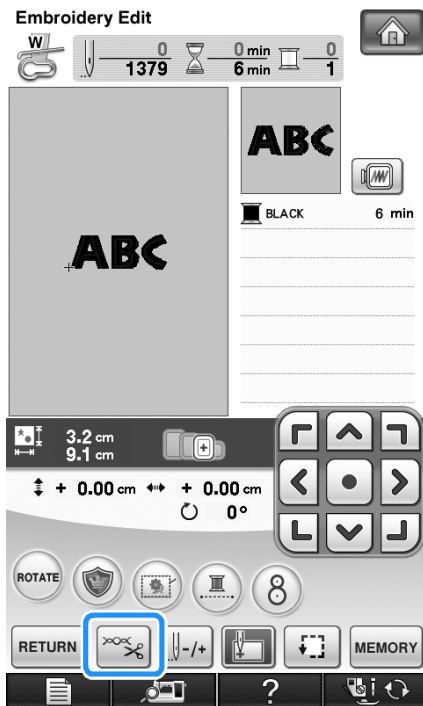
5 Press  .



6 Press  to turn off the automatic thread cutting function and then press  .

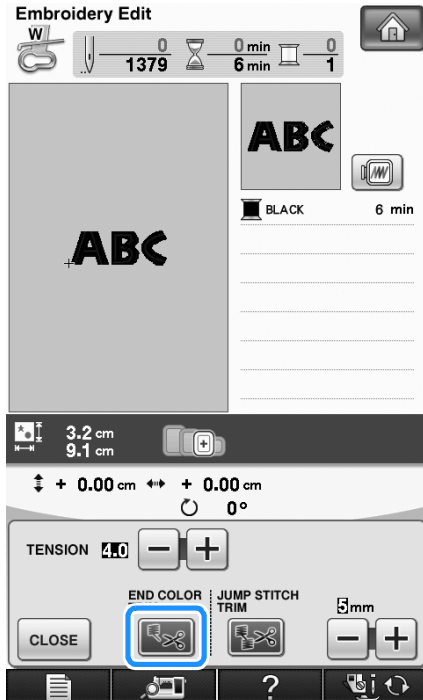

7 Press the "Start/Stop" button.

8 After the characters are embroidered, cut the threads to a generous length, remove the embroidery frame, and then attach the embroidery frame again so that the remaining characters ("DEF") can be embroidered.

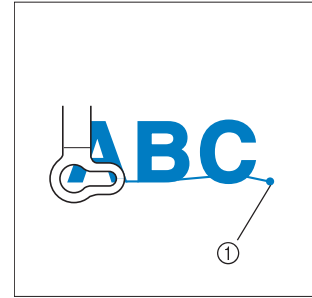

① End of the embroidering

9 As in step ①, select the character patterns for "DEF".

10 Press  .

11 Press  .

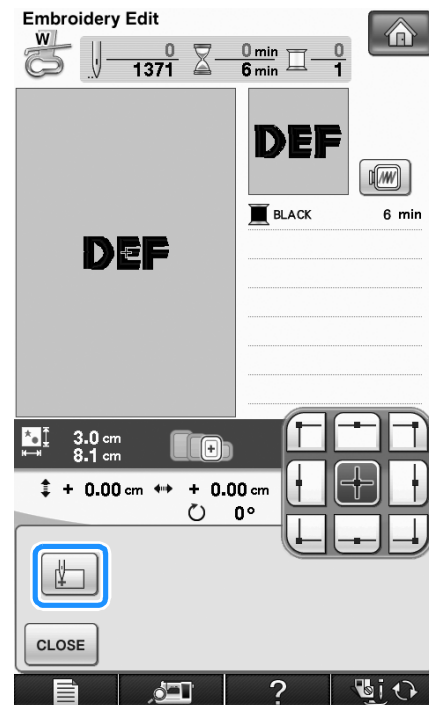

→ The needle is positioned in the lower-left corner of the pattern. The embroidery frame moves so that the needle is positioned correctly.

12 Press  .

13 Use  to align the needle with the end of embroidering for the previous pattern.

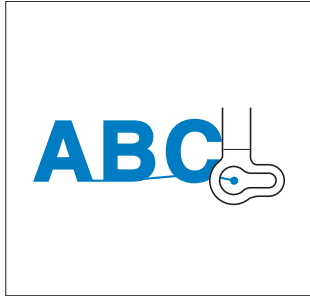

14 Press the “Start/Stop” button to begin embroidering the remaining character patterns.



Changing the Thread Color

You can change the thread color by moving the color to be changed to the top of the sewing order and selecting a new color from the thread colors in the machine.

1 In the pattern editing screen, press  .

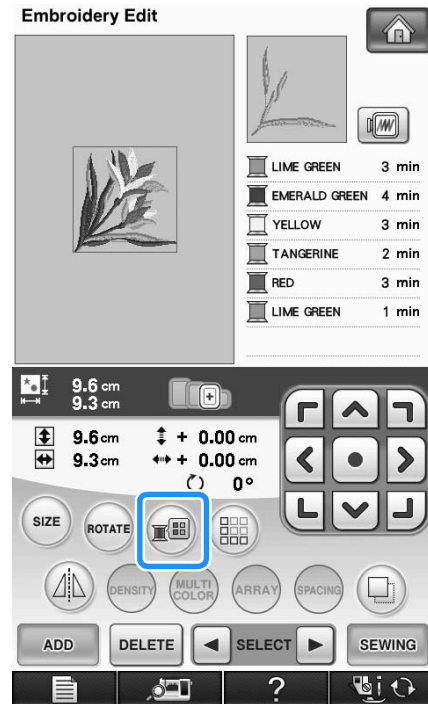

→ The thread color palette screen displays.

2 Press  or  to put the color you want to change at the top of the sewing order.

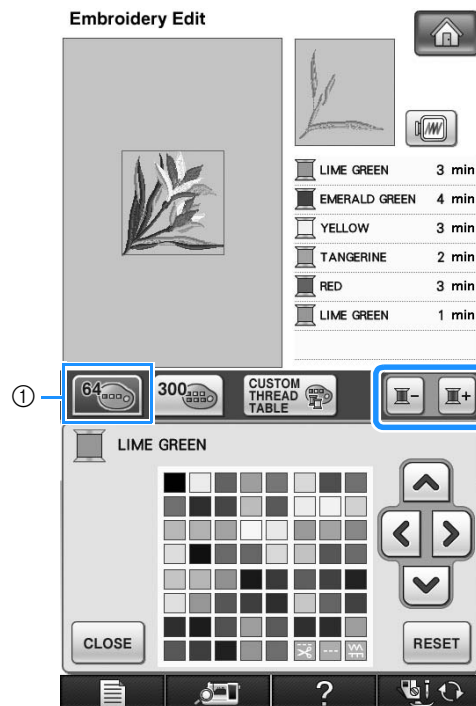

① 64 Embroidery threads table

3 Press to choose a new color from the color palette.

- * To return to the original color, press . If multiple colors have been changed, this command will return all colors to their original colors.
- * You can select colors from the color palette by directly touching the color selection with the touch pen.

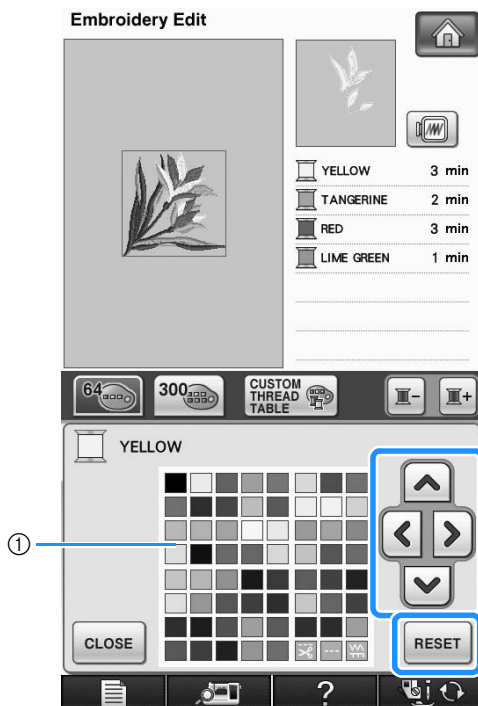

① Color palette

→ The selected color appears at the top of the sewing order.

4 Press .

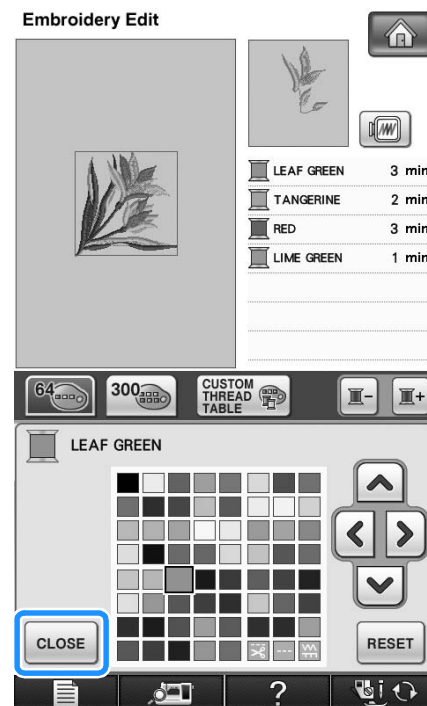

→ The display shows the changed colors.

Memo

- To select a color from the Custom Thread Table, “Choosing a Color from the Custom Thread Table” on page 283.

Creating a Custom Thread Table

You can create a custom thread table containing the thread colors that you most often use. You can select thread colors from the machine’s extensive list of thread colors from nine different thread brands. You can select any color and move the color to your custom thread table.



Note

- Some machines may already have an additional 300 Robison-Anton thread colors contained in the custom thread table.
- You have the option to completely clear, or to restore the Custom Thread Table to the original factory setting. Visit the website for Custom Thread Table Clear/Restore Program and instructions.

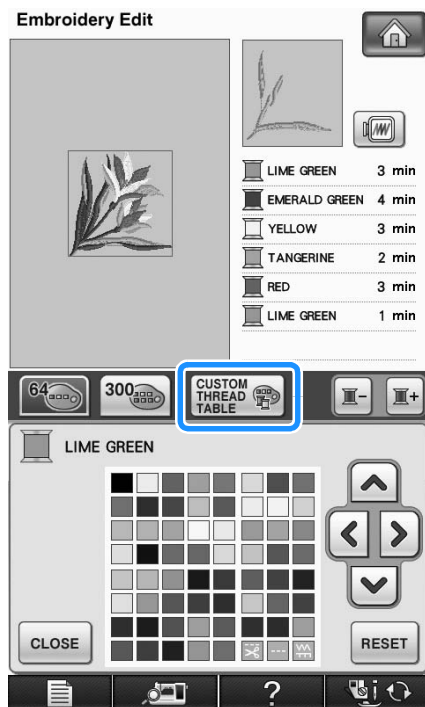
1 In the pattern editing screen, press  and then press .



2 Use , , ,  to choose where to add a color on the custom thread table.

- * You can choose colors from the custom thread from the custom thread table by directly touching the screen with the touch pen.
- * You can scroll through 100 colors at a time using  and  on the custom thread table.

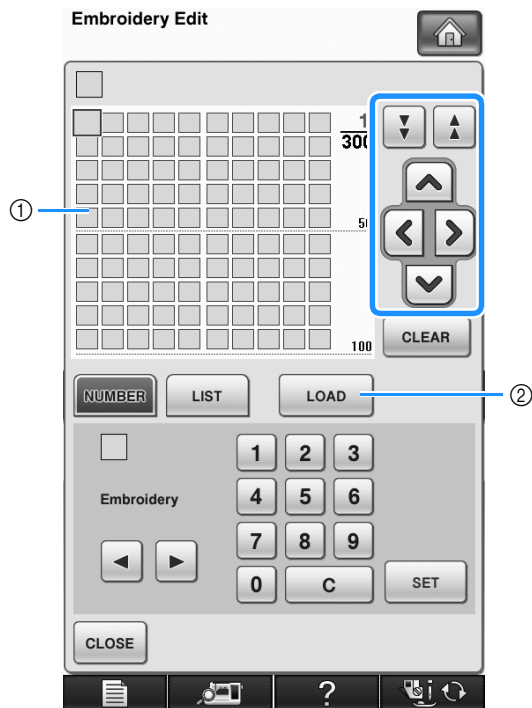

- ① Custom thread table
- ② Press  to download the clear and restore programs from the website

- 3 Use to select one of the thread brands in the machine.

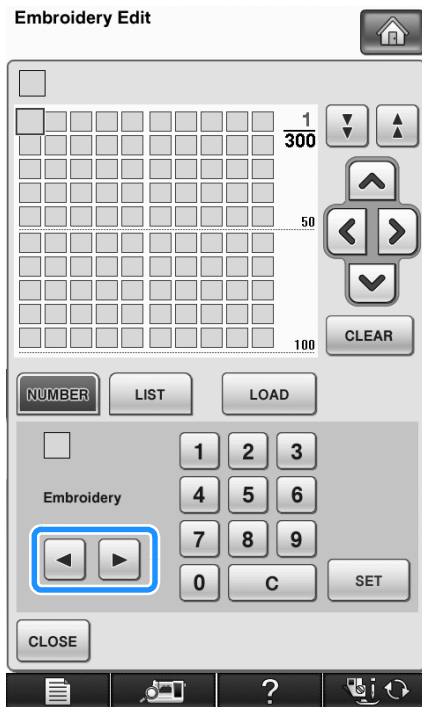

- 4 Use to enter a color's 4-digit number.

* If you make a mistake, press to erase the entered number, and then enter the correct number.

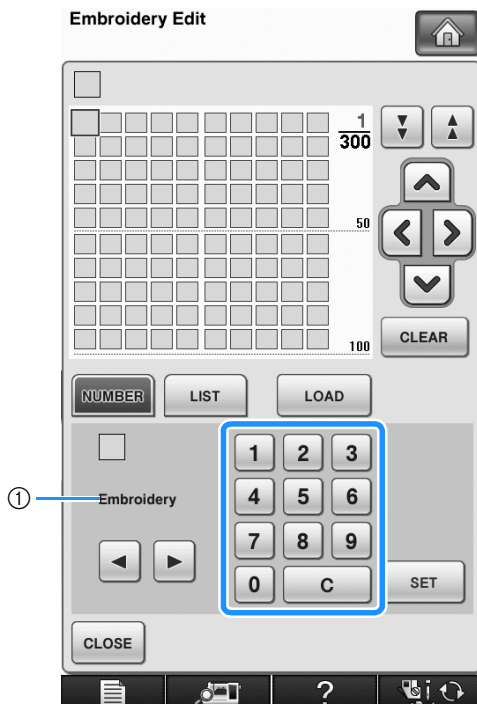

- ① Thread brand

- 5 Press .

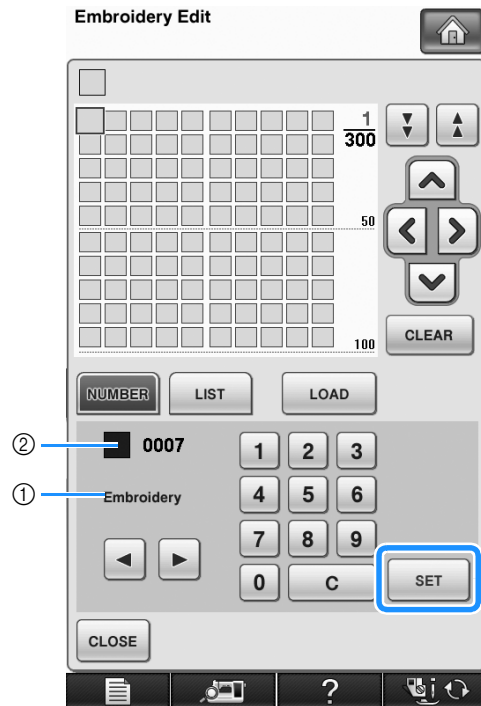

- ① Thread brand
 ② Entered thread color number
 → The selected thread color is set in the custom thread table.



Note

- If is not pressed, the thread color number will not be changed.

- 6 Repeat the previous steps until all desired thread colors are specified.

* To delete a specified color from the palette, press



7 Press **CLOSE** to return to the original screen.

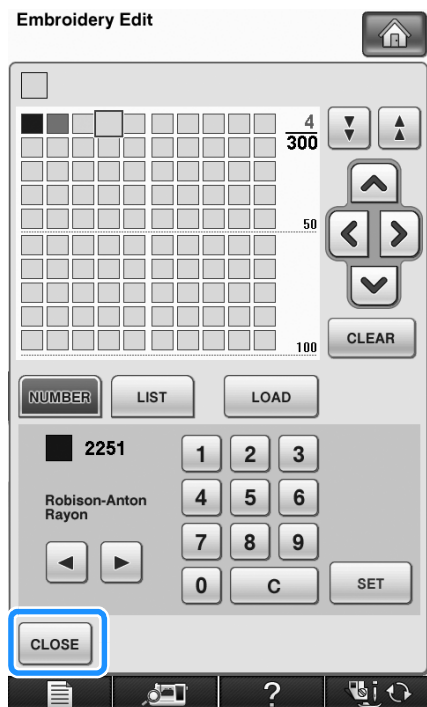

■ Adding a Color to the Custom Thread Table from the List

1 Repeat the previous steps **1** through **3** on page 279.

2 Press **LIST** to display the thread list.

3 Use **▲** **▼** to select a thread color.

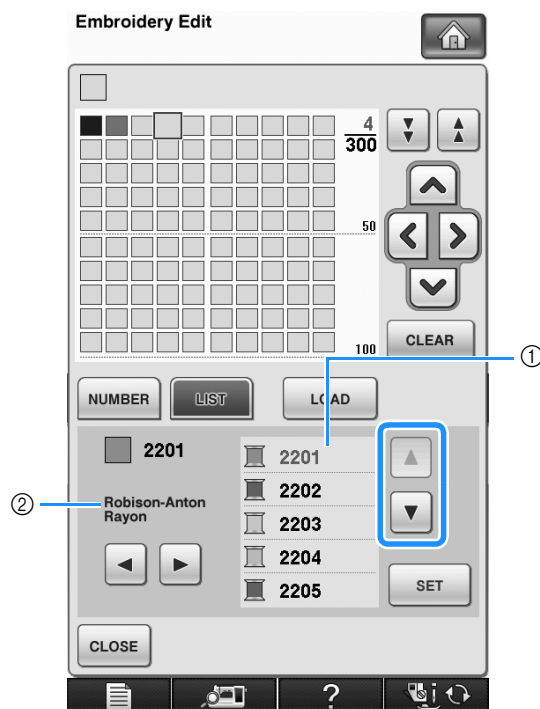

- ① Thread list
- ② Thread brand

4 Press **SET** .

5 Repeat the previous steps until all desired thread colors are specified.

* To delete a specified color from the palette, press

CLEAR .

6 Press **CLOSE** to return to the original screen.

Choosing a Color from the Custom Thread Table

You can select a color from the up to 300 thread colors you have set in the custom thread table.

1 Press .

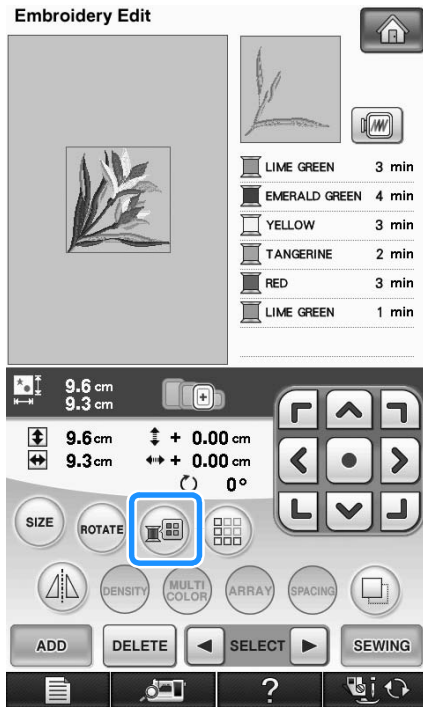

→ The thread color palette screen displays.

2 Press  or  to put the color you want to change at the top of the sewing order.

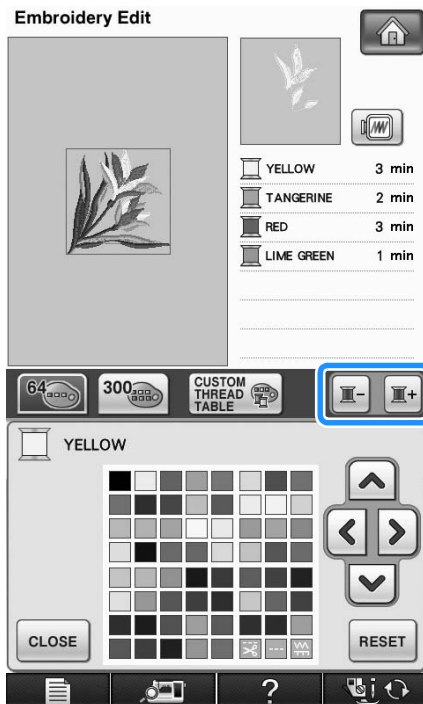

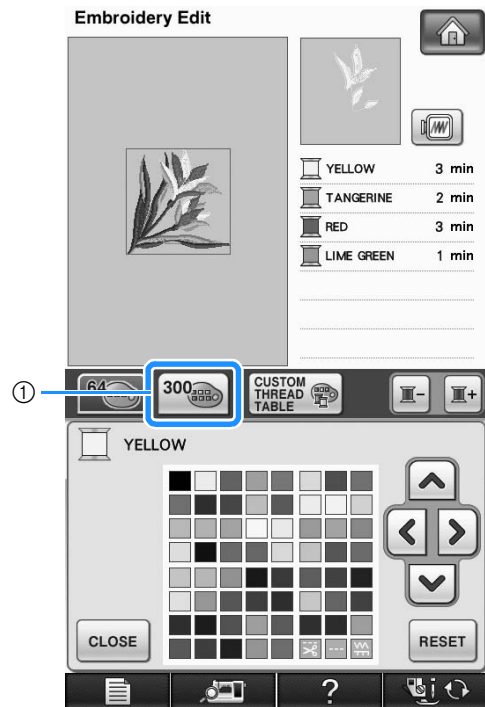

3 Press .



① Custom thread change key
→ The custom thread table will appear.

4 Press , , , or  to choose a new color from the custom thread table.

- * Use  and  to scroll through the custom thread table.
- * Press  to return to the original color.
- * You can choose colors from the custom thread table by directly touching the screen with the touch pen.

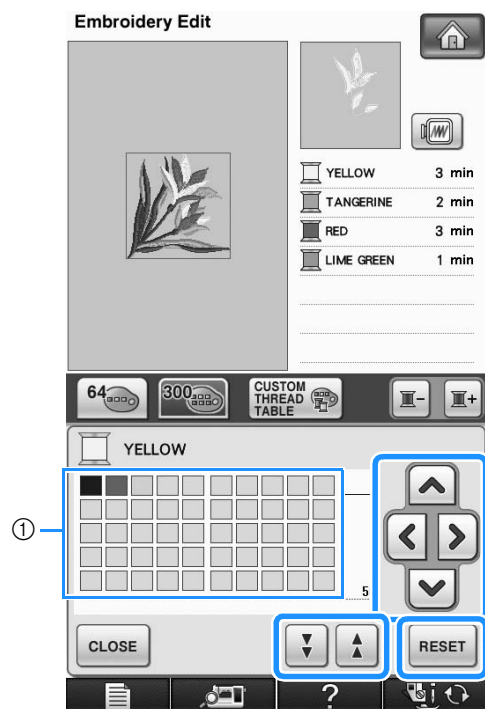

① Custom thread table
→ The display shows the changed colors.

5 Press .

Designing Repeated Patterns

■ Sewing Repeated Patterns

Using the border function, you can create stitches using repeated patterns. You can also adjust the spacing of the patterns within a repeated pattern stitch.

1 Select a pattern, and then press  .

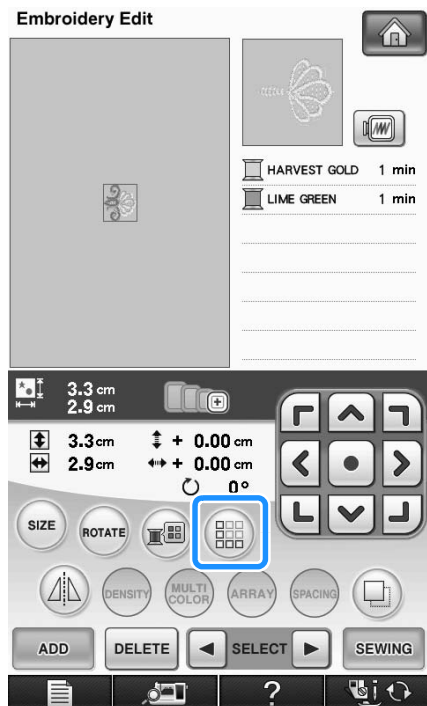

2 Press  .



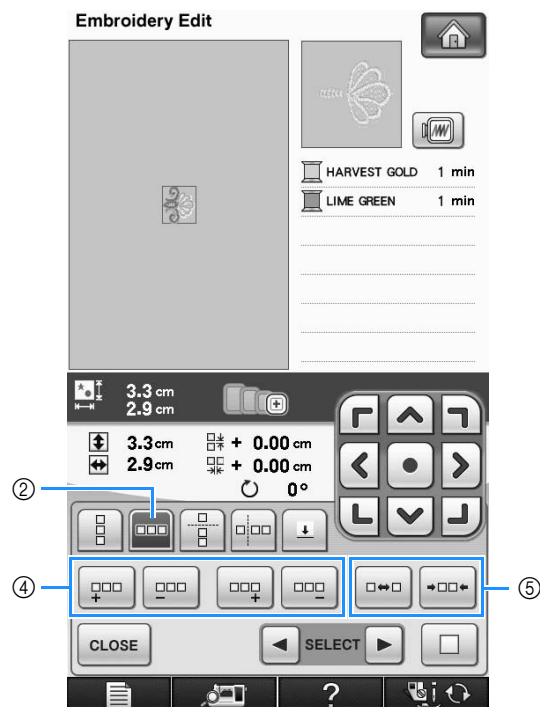
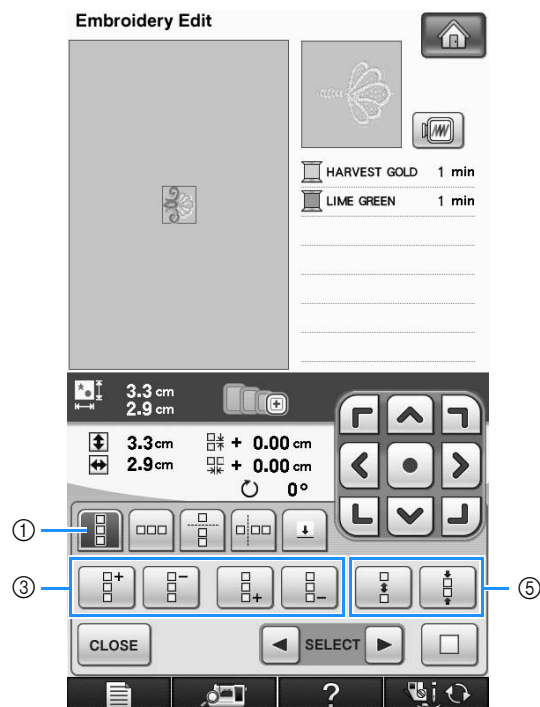

3 Select the direction in which the pattern will be repeated.





- ① Vertical direction
 - ② Horizontal direction
 - ③ Repeating and deleting vertical keys
 - ④ Repeating and deleting horizontal keys
 - ⑤ Spacing keys
- The pattern direction indicator will change depending on the direction selected.

4 Use  to repeat the pattern on top and  to repeat the pattern at the bottom.

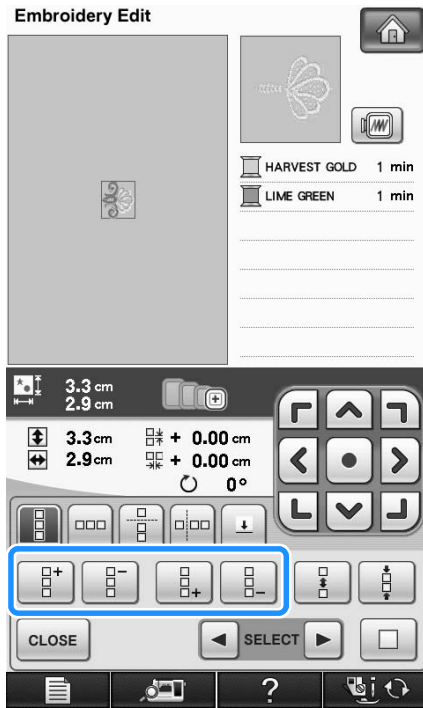
- * To delete the top pattern, press .
- * To delete the bottom pattern, press .



5 Adjust the spacing of the repeated pattern.

- * To widen spacing, press .
- * To tighten spacing, press .

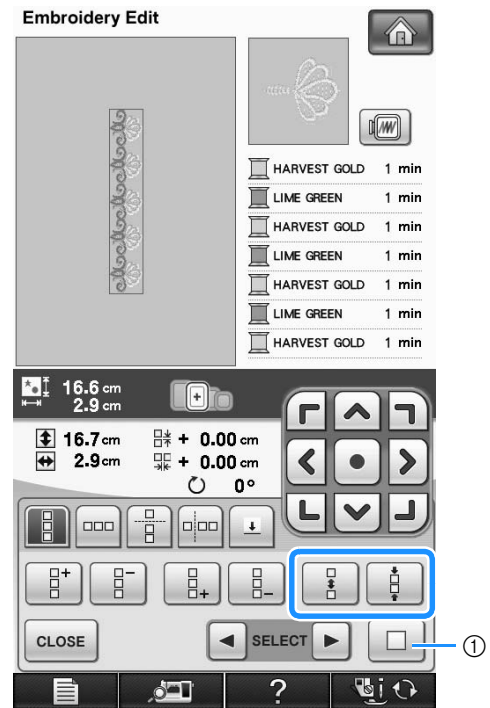

- ① Press  to change a repeated pattern back to one single pattern.



Memo

- You can only adjust the spacing of patterns included in the red frame.

6 Complete repeated patterns by repeating steps **3** through **5**.

7 Press **CLOSE** to finish repeating.

Memo

- When there are two or more patterns, all patterns will be grouped together as one pattern in the red frame.

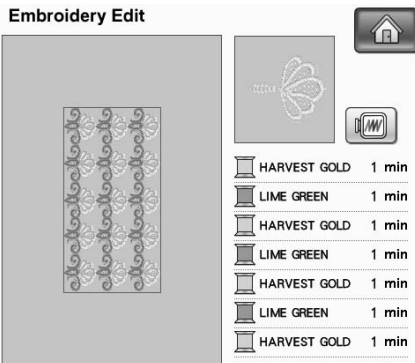



- When changing the direction in which the pattern will be repeated, all of the patterns in the red frame will automatically be grouped as one repeating unit. Press  to change a repeated pattern back to one single pattern. See the following section on how to repeat one element of a repeated pattern.

Repeating One Element of a Repeated Pattern

By using the Cut function, you can select one element of a repeated pattern and repeat only that single element. This function allows you to design complex repeated patterns.

1 Choose the direction in which the repeated pattern will be cut.

- * Press  to cut horizontally.
- * Press  to cut vertically.

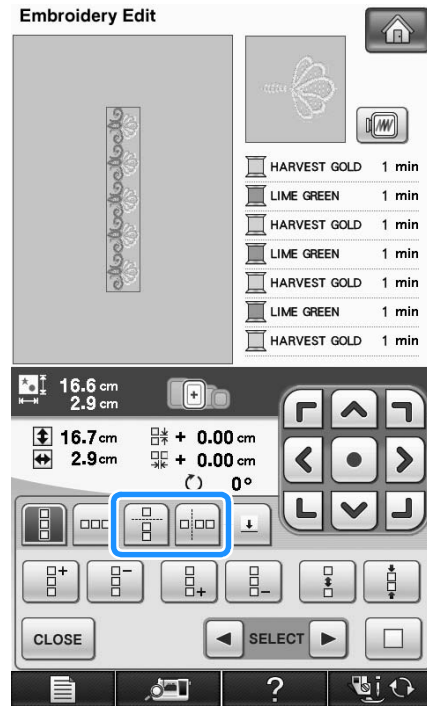

→ The pattern direction indicator will change depending on the direction selected.

2 Use  and  to select the cut line.

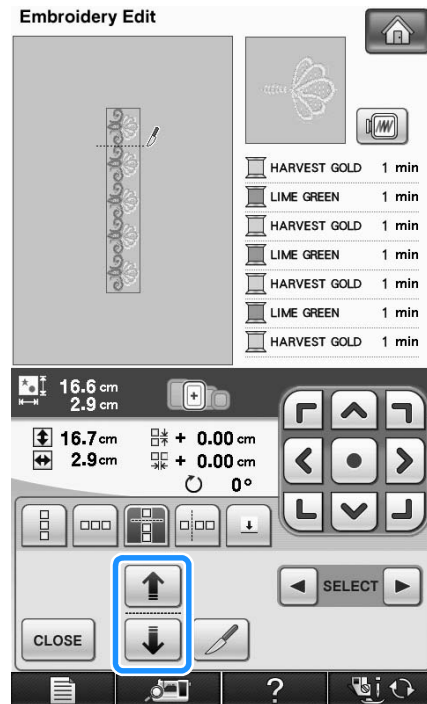

→ The cut line will move.

3 Press .

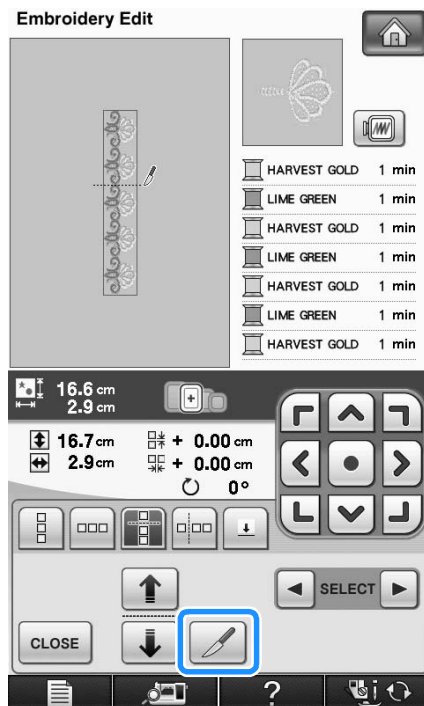

→ The repeated pattern will be divided into separate elements.

4 Press .

5 Use  and  to select the element to repeat.

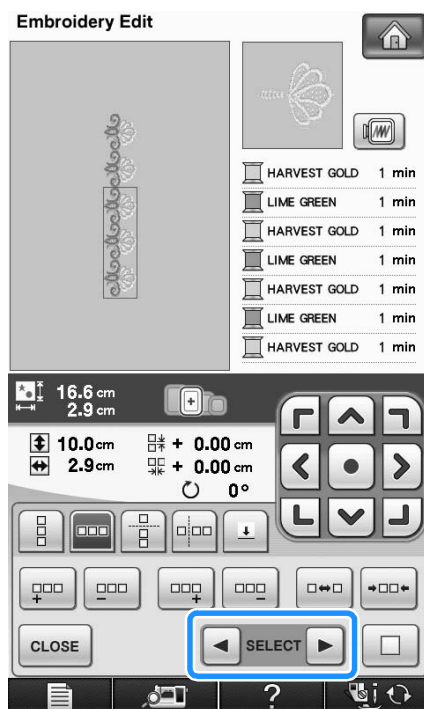

6 Repeat the selected element.

7 Press  to finish repeating.

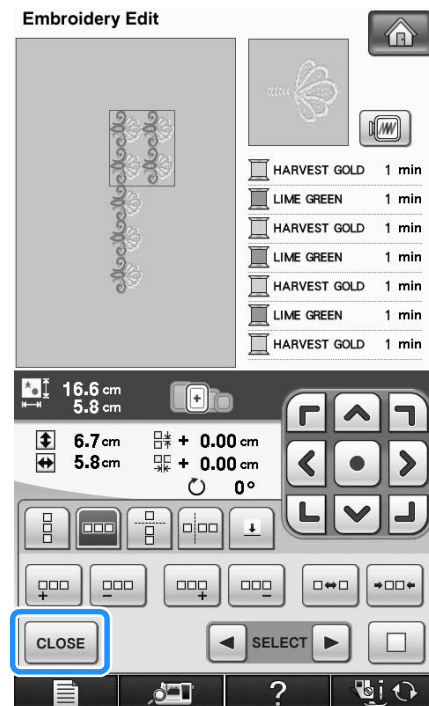

Note

- Once you have cut a repeated pattern into separate elements, you cannot return to the original repeated pattern.
- Each element can be edited separately in the edit screen. See “Selecting combined embroidery patterns” on page 293.

Color Sorting Repeated Patterns

Press  to automatically change the sewing order of colors in combined border embroidery patterns so that the same color can be continuously sewn. This allows you to continue sewing without repeatedly changing the upper thread or changing the sewing order manually.



Memo

- In combined stitch patterns that contain two or more border patterns or other patterns combined with border patterns, the sewing order of only the border patterns is changed.
- When a group of two or more patterns using border patterns is repeated, the sewing order is changed so that the same color can be sewn continuously in each pattern.

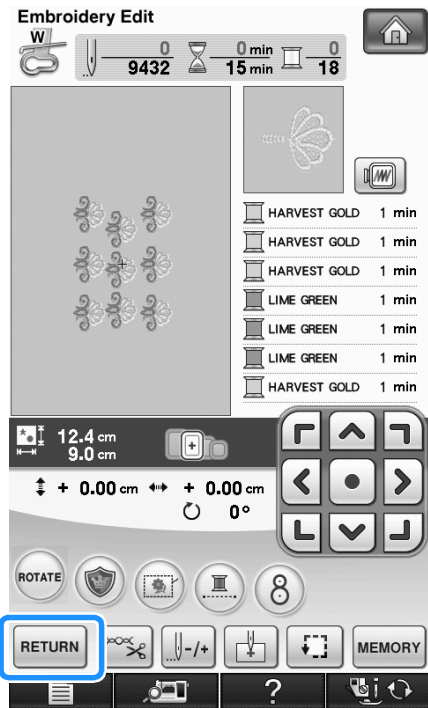
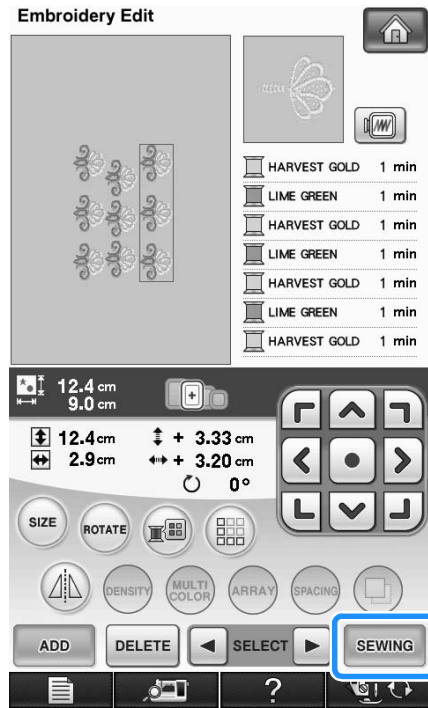
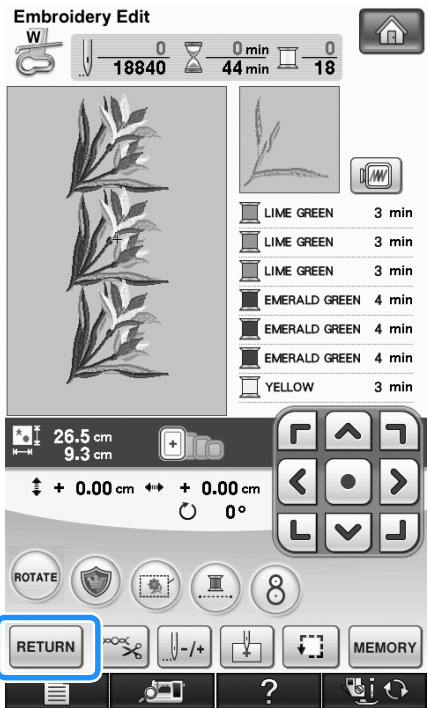
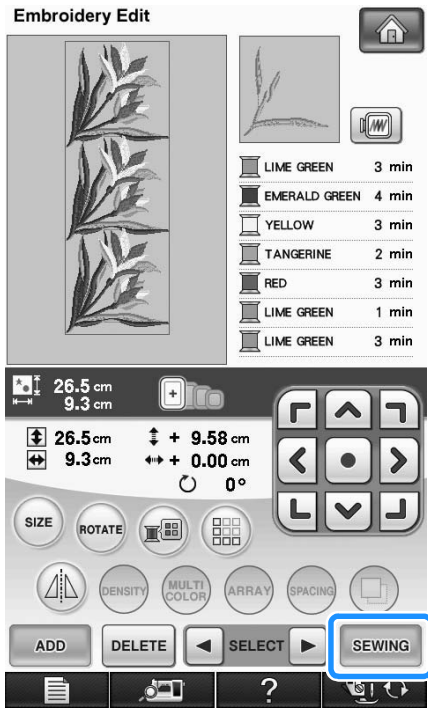

■ Assigning Thread Marks

By sewing thread marks, you can easily align patterns when sewing a series. When sewing is finished on a pattern, a thread mark in the shape of an arrow will be sewn using the final thread. When sewing a series of patterns, use the point of this arrow for positioning the following designs to be sewn.

Memo

- When repeatedly sewing individual patterns, thread marks can be sewn around the perimeter of the pattern only.

1 Press .



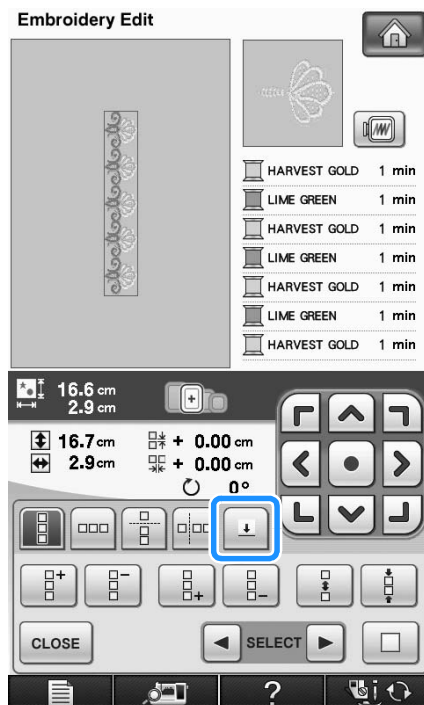

2 Press .

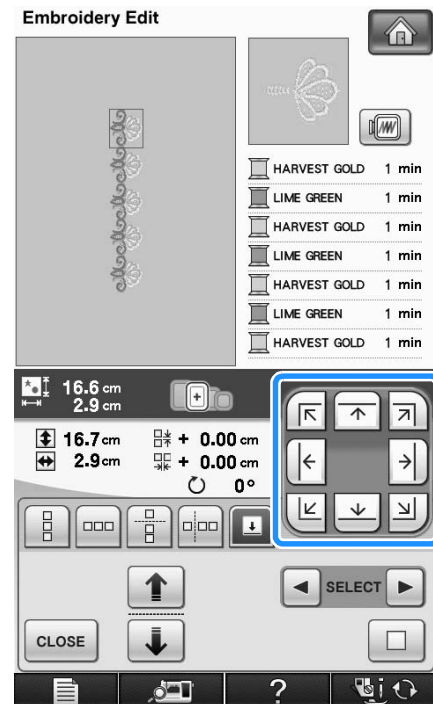

3 Press  to select the thread mark to be sewn.



Memo

- When there are two or more elements, use  and  or  and  to select a pattern that you want to assign a thread mark(s) to.

4 Press .

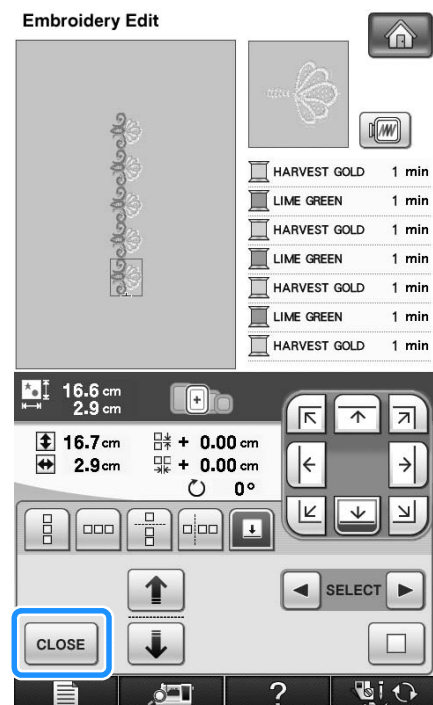

Duplicating a Pattern

1 Press  .

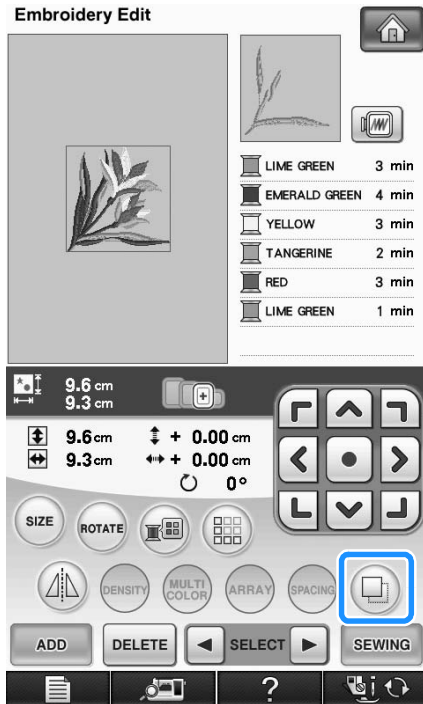

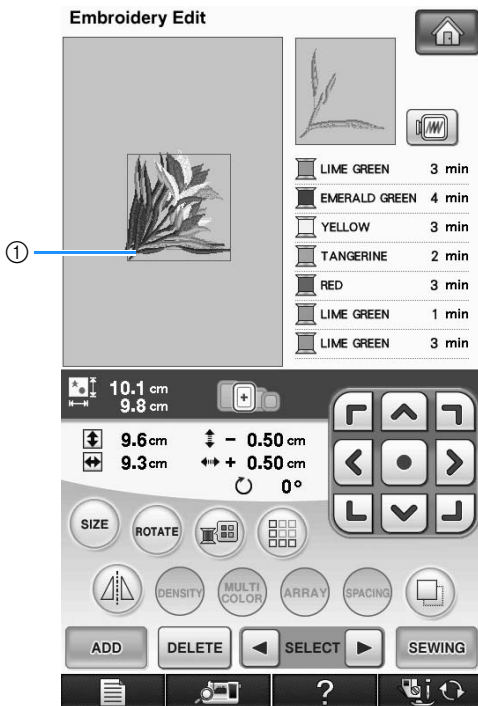

→ The duplicate is positioned over the original pattern.



① Duplicated pattern





Note

- If multiple patterns are displayed in the screen, only the pattern selected using  and  is duplicated.
- Move and edit each duplicated pattern individually.

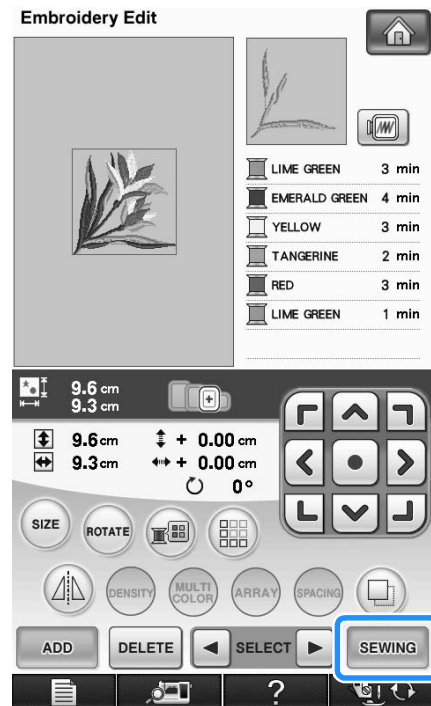

After Editing

1 Press  .



- * To combine the pattern with other patterns, select  (see page 291).
- * See page 212 for more information about sewing patterns.

Memo

- If you want to return to the edit screen after pressing , press .

COMBINING PATTERNS



Editing Combined Patterns

Example: Combining alphabet characters with an embroidery pattern and editing



1 Press  to select an embroidery pattern.



2 Use  to view 2/7, then select .

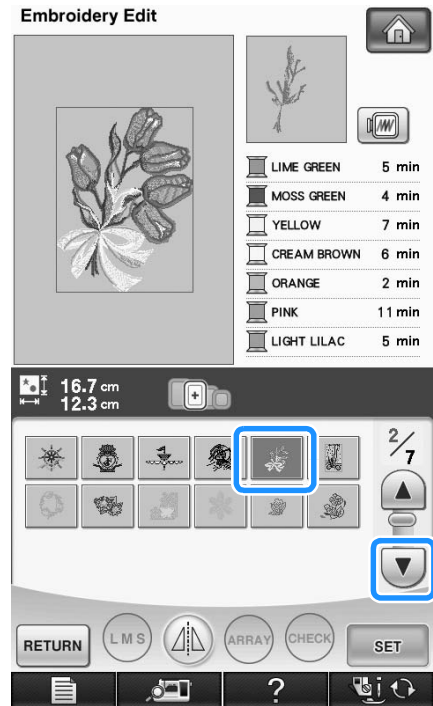

3 Press .

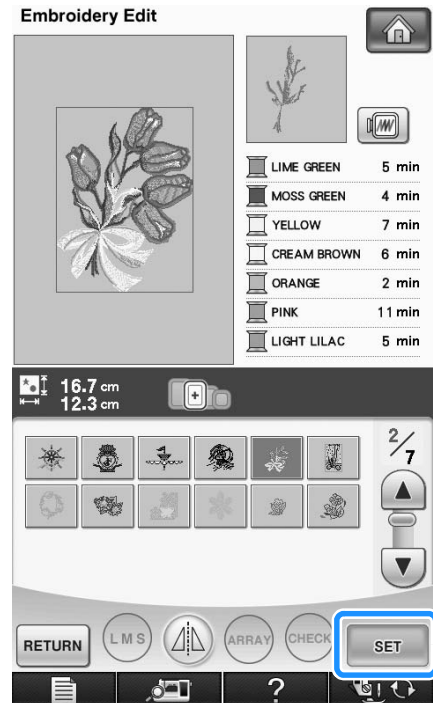

6

Embroidery Edit

4 Press **ADD**.

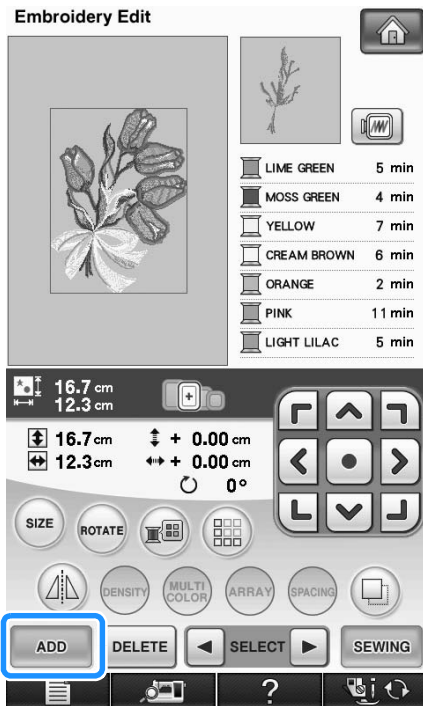

5 Press **AA** to enter the alphabet characters.

* Press **RETURN** to return to the previous screen.

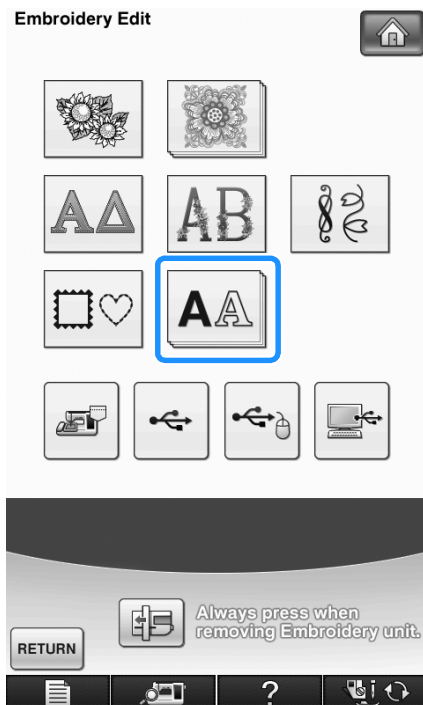

6 Select **ABC** and enter "Spring".

* After selecting **S**, press **abc** to change the character case, then enter the remaining characters.

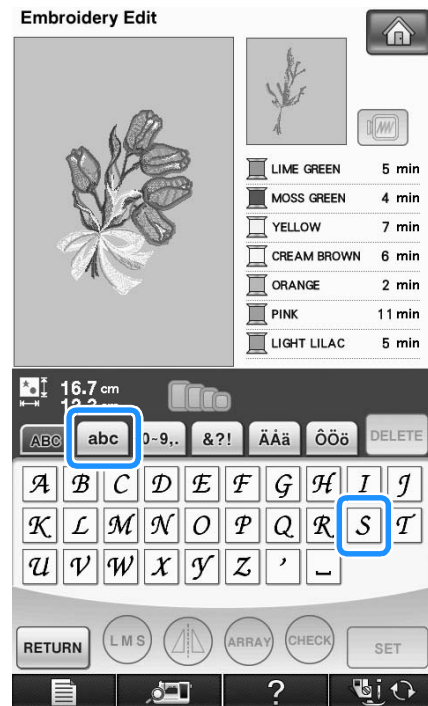

→ The characters you enter will be displayed in the center of the display.

7 Press **SET**.

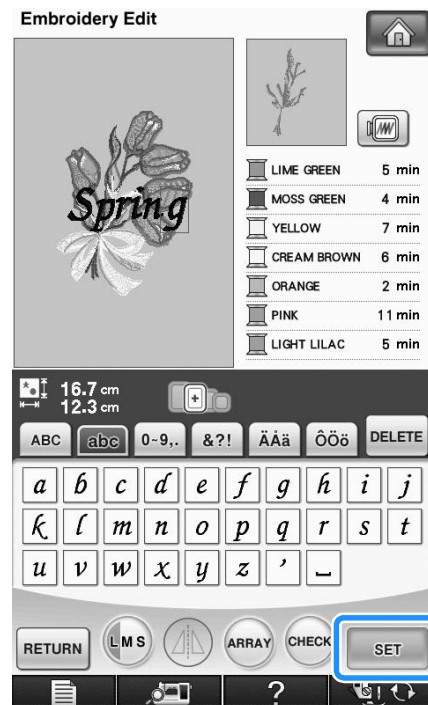

8 Use **← ↑ → ↓** to move the characters.

* With a USB mouse, your finger or the touch pen, drag the characters to move them.

- 9 Press **ARRAY** to change the layout of the characters. Press **CLOSE**.

* See page 271 for more information about changing the layout.

- 10 Press **MULTI COLOR** to change the color of the characters.

* See page 278 for more information about changing the color.



- 11 When all editing is finished, press **SEWING**.

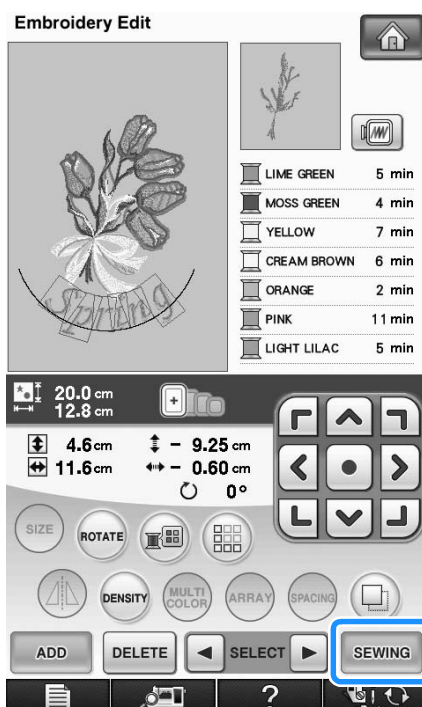

Selecting combined embroidery patterns

If multiple patterns have been combined, use



to select the pattern to be edited. If a USB mouse is connected, the pattern can be selected by clicking it. Move the mouse to position the pointer over the desired pattern, and then click the left mouse button. In addition, patterns can be selected by directly touching the screen with your finger or touch pen.

Memo

- Use **SELECT** to select patterns that are overlapping and cannot be selected by clicking them or by touching the screen.

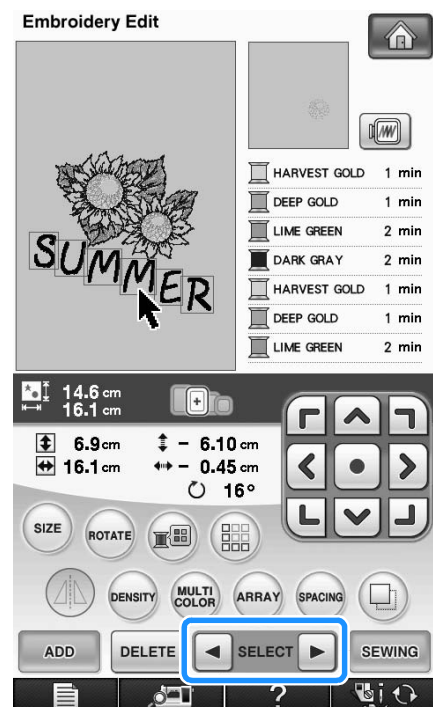

6

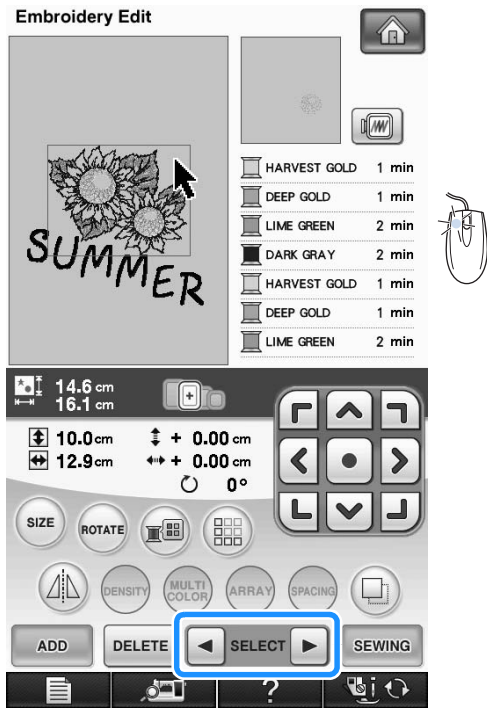

Sewing Combined Patterns

Combined patterns will be embroidered in the order they were entered. In this example, the embroidery order will be as follows:

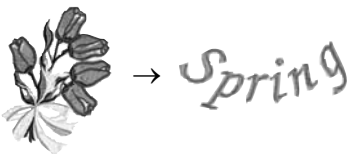

Note

- Follow the directions in “Sewing Embroidery Patterns” on page 213.

1 Embroider  by following the color order on the right side of the display.

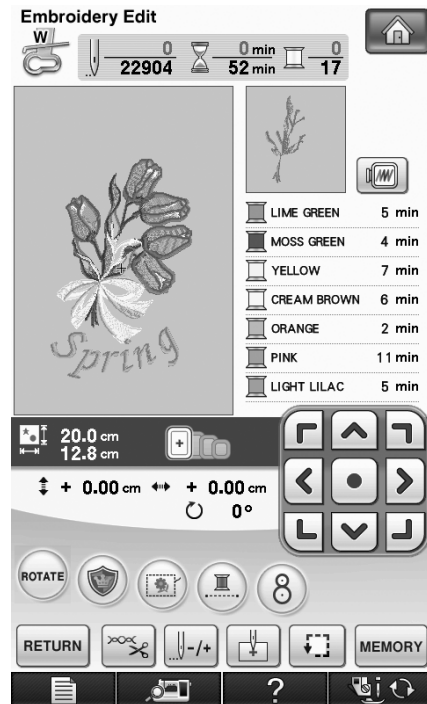

→ After the flowers are embroidered, the [+] cursor will move to the “Spring” part of the pattern.

2 Embroider *Spring* .

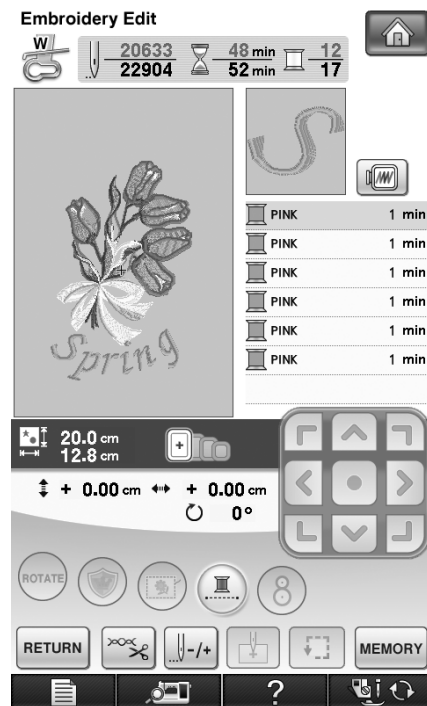

→ When “Spring” is embroidered, the display returns to the sewing screen.

VARIOUS EMBROIDERING FUNCTIONS

Uninterrupted Embroidering (Using a Single Color)

A selected pattern can be stitched out in one color instead of multicolor. The machine will hesitate but not stop between color steps, and then

continue till the pattern is completed. Press  for the multicolor steps to become shaded and the selected pattern will embroider in a single color, instead of changing the thread while

embroidering. Press  again to return to the pattern's original settings.

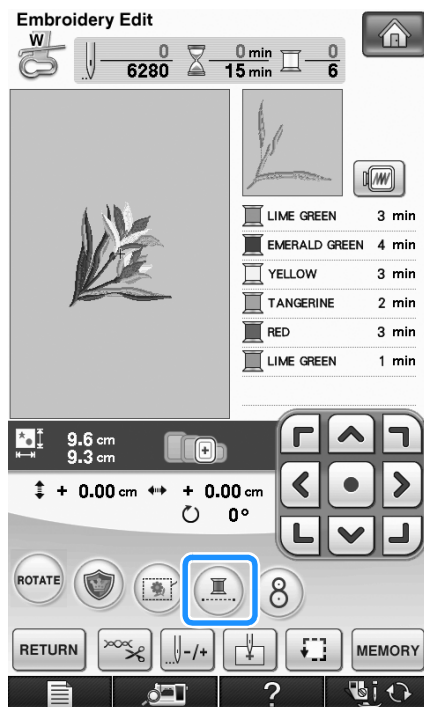



Basting Embroidery

Before embroidering, basting stitches can be sewn along the outline of the pattern. This is useful for embroidering fabric that cannot have stabilizer material affixed with an iron or adhesive. By stitching stabilizer material to the fabric, shrinkage of the stitching or misaligned pattern can be minimized.



Note

- It is recommended to finish combining and editing the pattern before selecting the basting setting. If the pattern is edited after selecting the basting setting, the basting and pattern may become misaligned, and the basting under the pattern may be difficult to remove after embroidering is complete.

- Press , and then display 7/7 of the settings screen.
- Use  and  to specify the distance from the pattern to the basting stitching.

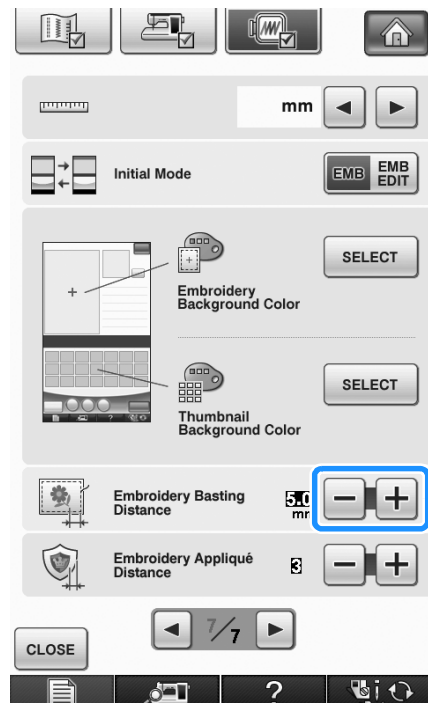

Memo

- The higher the setting, the farther the basting is from the pattern.
- The setting remains selected even if the machine is turned off.

- 3 Press **CLOSE** to return to the previous screen.
- 4 Press **SEWING**.
- 5 Press  to select the basting setting.

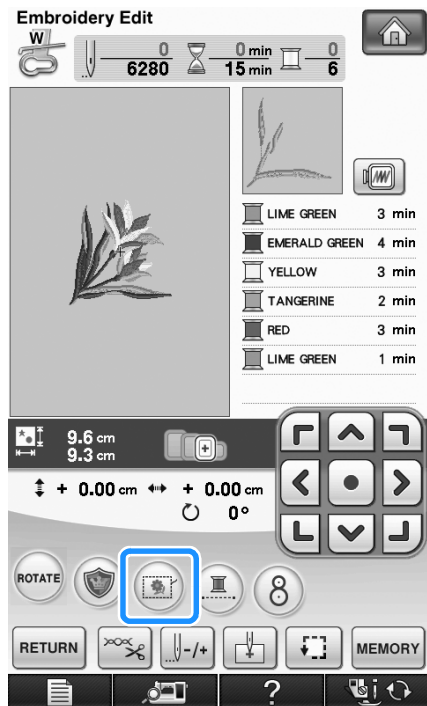

Note

- When  is pressed, the pattern is moved to the center. After selecting the basting setting, move the pattern to the desired position.

Memo

- To cancel the setting, press .
- If no pattern is selected, the key appears gray and cannot be selected.

→ Basting is added to the beginning of the sewing order.

- 6 Press the “Start/Stop” button to begin embroidering.
- 7 When embroidering is finished, remove the basting stitching.



Creating an Appliqué Piece

Appliqué pieces can be created from the built-in patterns and patterns on embroidery cards. This is convenient for fabrics that cannot be embroidered or when you wish to attach an appliqué to a garment.

■ Creating an Appliqué Piece

The following pattern will be used to create an appliqué piece.



Note

- Felt or denim fabrics are recommended to make the appliqué piece. Depending on the pattern and fabric used, lighter weight fabrics may cause the stitching to appear smaller.
- For best results, be sure to use stabilizer material for embroidering.
- Select a frame that matches the pattern size. Frame options are displayed on the LCD screen.
- When making appliqué pieces, do not use the border embroidery frame. Depending on the pattern density and fabric used, shrinkage of the stitching may occur.

1 Select the pattern, and edit it if necessary.

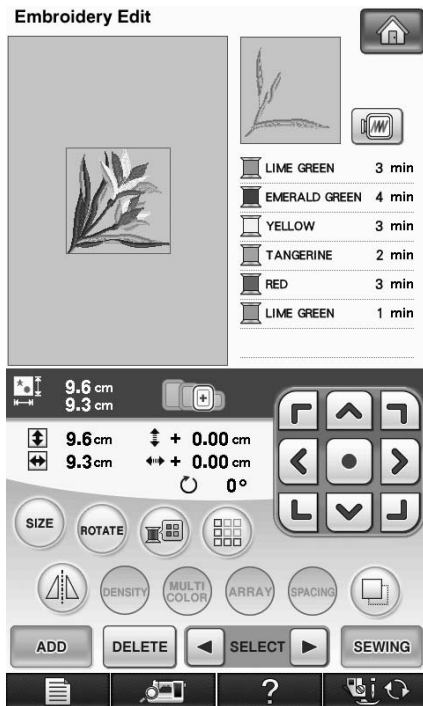

Note

- Finish combining and editing the pattern before selecting the appliqué setting. If the pattern is edited after selecting the appliqué setting, the appliqué stitching and pattern may become misaligned.
- Since an outline is added, the pattern for an appliqué piece (when the appliqué setting is selected) will be larger than the original pattern. First, adjust the size and position of the pattern as shown below.

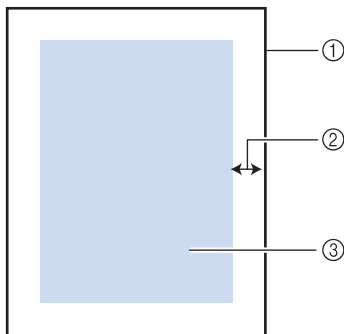

- ① Embroidering area
- ② Approx. 1 cm
- ③ Pattern size

2 Press , and then display 7/7 of the settings screen.

3 Use  and  to specify the distance between the pattern and the appliqué outline.

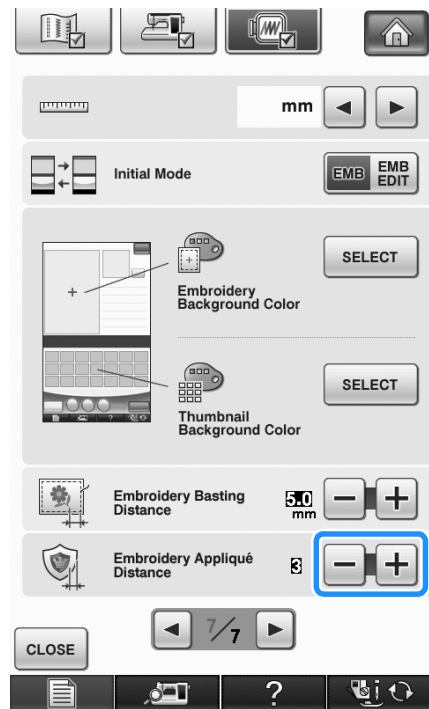

Memo

- Three settings are available: 1 (narrow), 2 (normal) and 3 (wide).

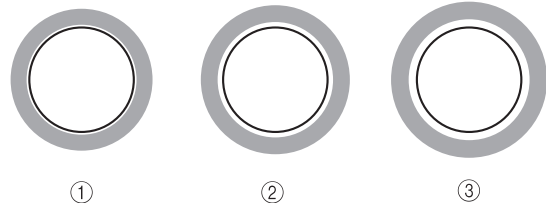

- The setting remains selected even if the machine is turned off.

4 Press  to return to the previous screen.

5 Press .

6 Press  to select the appliqué setting.

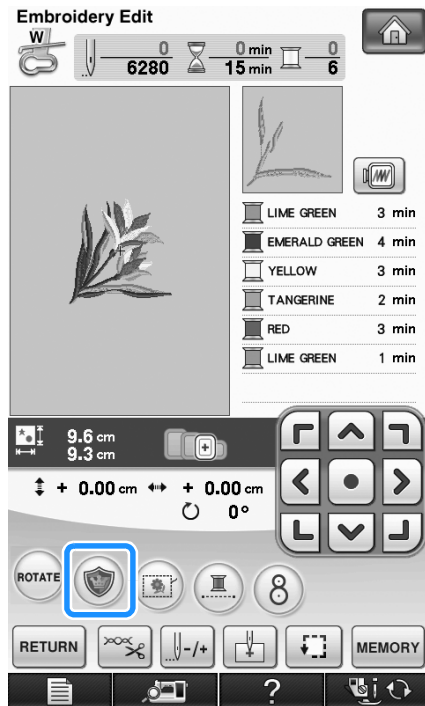

Note

- When  is pressed, the pattern is moved to the center. After selecting the appliqué setting, move the pattern to the desired position.

Memo

- To cancel the setting, press .
- If no pattern is selected, the key appears gray and cannot be selected.

→ The steps for creating the appliqué piece are added to the sewing order.

Memo

- Three steps are added to the sewing order: appliqué cutting line, position of pattern placement on the garment, and appliqué stitching.

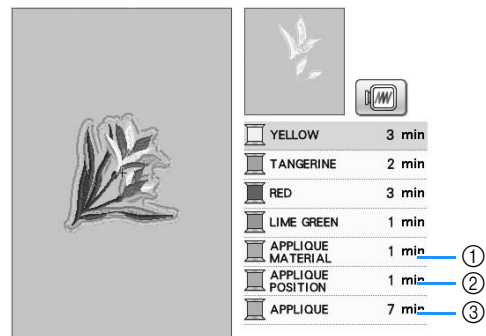

- ① Cutting line for appliqué
- ② Position of pattern placement on garment
- ③ Appliqué stitching

Note

- An appliqué piece cannot be created if the pattern is too large or too complicated or a combined pattern is separated. Even if the selected pattern fits within the embroidering area, the entire appliqué pattern may exceed the embroidering area when the outline is added. If an error message appears, select a different pattern or edit it.

7 Fuse or stick a piece of stabilizer to the back of the felt or denim fabric to be used as the appliqué piece.

Note

- For best results, be sure to use stabilizer material for embroidering.

8 Hoop the appliqué fabric in the embroidery frame, attach the embroidery frame to the machine, and then start embroidering.

- 9** After the pattern is embroidered, thread the machine with the thread for the cutting line, and then sew the cutting line (APPLIQUE MATERIAL).

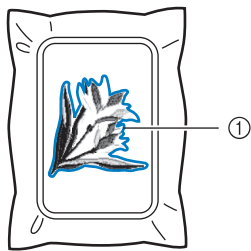

① Cutting line for appliqué



Memo

- We recommend using thread for the cutting line that is closest to the color of the fabric.

- 10** Remove the appliqué material from the embroidery frame, and then carefully cut along the stitching. After cutting, carefully remove all of the cutting line thread.

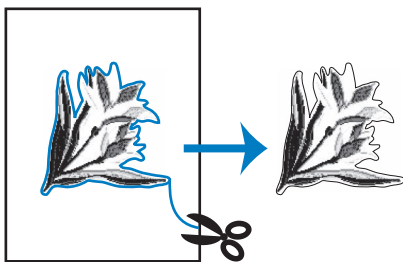

Note

- Depending on the pattern density and fabric used, there may be shrinking of the pattern or the appliqué may be misaligned with the placement line. We recommend cutting slightly outside of the cutting line.
- When using patterns that are vertically and horizontally symmetrical, use a chalk pencil to indicate the pattern orientation before cutting it out.
- Carefully cut out the pattern on the outline you just sewed. Do not cut inside the cutting line, otherwise the appliqué fabric will not be caught by the appliqué stitch.

- 11** Use two layers of adhesive water-soluble stabilizer material with their sticky sides together, and then hoop them in the embroidery frame.

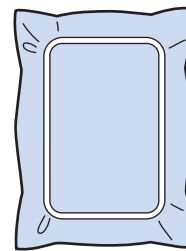

Note

- If water-soluble stabilizer is used, it is not necessary to remove the stabilizer material after sewing the appliqué outline. To reduce shrinkage of the pattern, we recommend using water-soluble stabilizer.
- Put together two layers of water-soluble stabilizer, otherwise the stabilizer material may tear during embroidering.

- 12** Thread the machine with the thread for the outline from step 14, and then sew the placement line for the appliqué position (APPLIQUE POSITION).

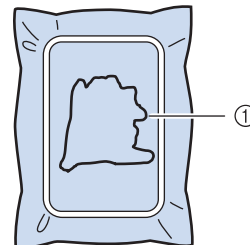

① Pattern placement line

- 13** Lightly apply glue or spray adhesive, and paste the appliqué piece so that it aligns with the placement line.

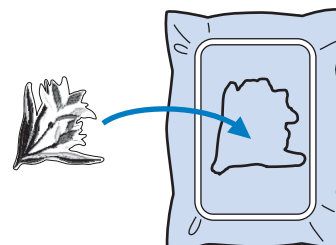

Note

- Before pasting the appliqué piece down, make sure the appliqué piece is positioned correctly within the placement line.

- 14** With the machine threaded using the thread for the outline from step 12, sew the outline (APPLIQUE).

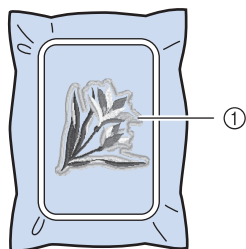

① Outline of appliqué piece

Memo

- The outline is sewn using satin stitching.
- Some glue may get onto the presser foot, needle, and needle plate at this time. Finish embroidering the appliqué pattern, and then clean off the glue.

- 15** After embroidering is finished, remove the stabilizer material from the embroidery frame.

- 16** Use scissors to cut the excess water-soluble stabilizer from outside the appliqué outline.

- 17** Soak the appliqué piece in water to dissolve the water-soluble stabilizer.

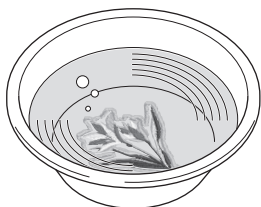

- 18** Dry the appliqué piece, and then iron it if necessary.

Note

- Do not apply a strong force when ironing, otherwise the stitching may be damaged.

Using a Frame Pattern for the Outline

Using a frame pattern, the desired shape can be added as the outline of the appliqué.



- 1** Perform the operations described in steps 1 through 4 of “Creating an Appliqué Piece” on page 296.

- 2** Select the desired frame shape and pattern, and add it to the appliqué pattern.

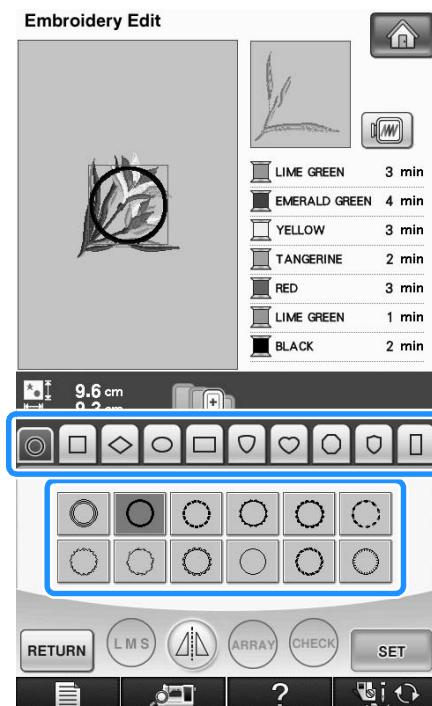

- 3** Edit the frame pattern to fit the size of the appliqué pattern.

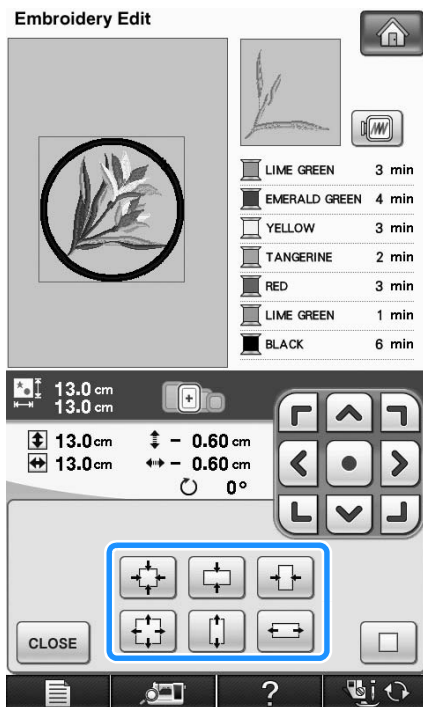

- 4** Press **CLOSE** and then press **SEWING**.

- 5** Press  to select the appliqué piece setting.

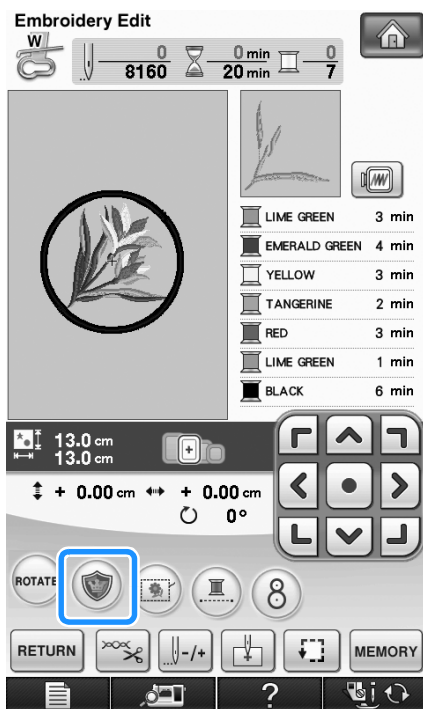

- 6** Press **RETURN**.

- 7** Use **SELECT** to select the frame pattern, and then press **DELETE** and **OK**.



→ The frame pattern is deleted.

- 8** Press **SEWING**.

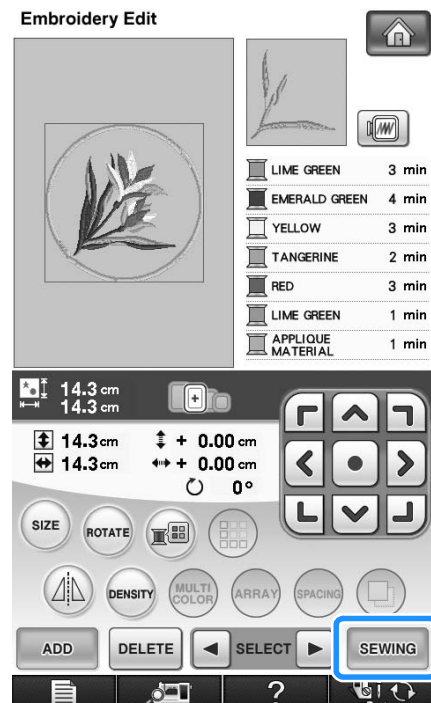

- 9** Continue with step **7** of “Creating an Appliqué Piece” on page 296 to complete the appliqué piece.

Using the Built-In Camera to Align the Embroidering Position

The embroidering positioning can easily be aligned using the machine's built-in camera and the included embroidery positioning sticker.



Note

- When embroidery frame (small) is installed, the built-in camera cannot be used to align the embroidering position. Install embroidery frame (medium) or a larger embroidery frame.

1 Affix the embroidery positioning sticker to the location in the fabric to be embroidered. Place the embroidery positioning sticker so that the center of the larger circle is at center of the embroidery pattern.

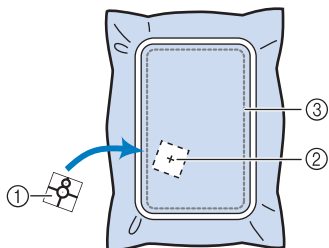

- ① Embroidery positioning sticker
- ② Center of the embroidery pattern
- ③ Embroidery field



Note

- When inserting the fabric in the embroidery frame, check that the embroidery pattern fits within the embroidery field for the frame that is used.

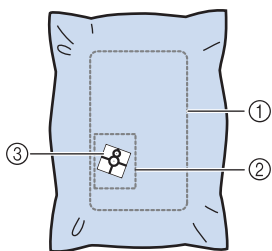

- ① Embroidery field
 - ② Embroidery pattern
 - ③ Embroidery positioning sticker
- Depending on the type of fabric that is used, a part of the embroidery positioning sticker may remain attached when it is peeled off. Before using the embroidery positioning sticker, check that it can be cleanly removed from a scrap piece of the fabric to be used.

2 After selecting the pattern, press **SEWING**, and then press **8**.

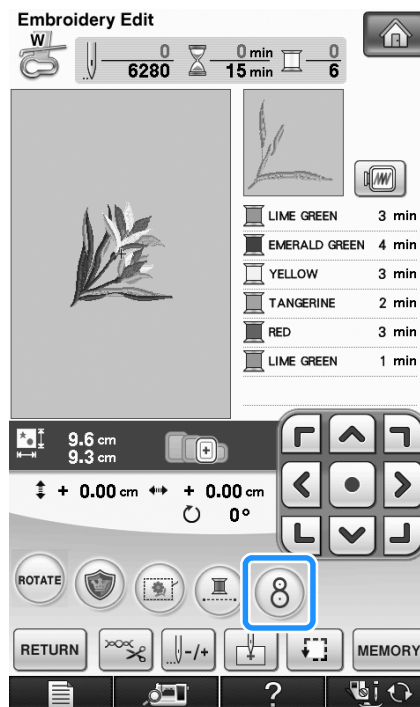

→ A window appears so that the area containing the embroidery positioning sticker can be selected.

- 3** From the areas shown in the window, select the area containing the embroidery positioning sticker.

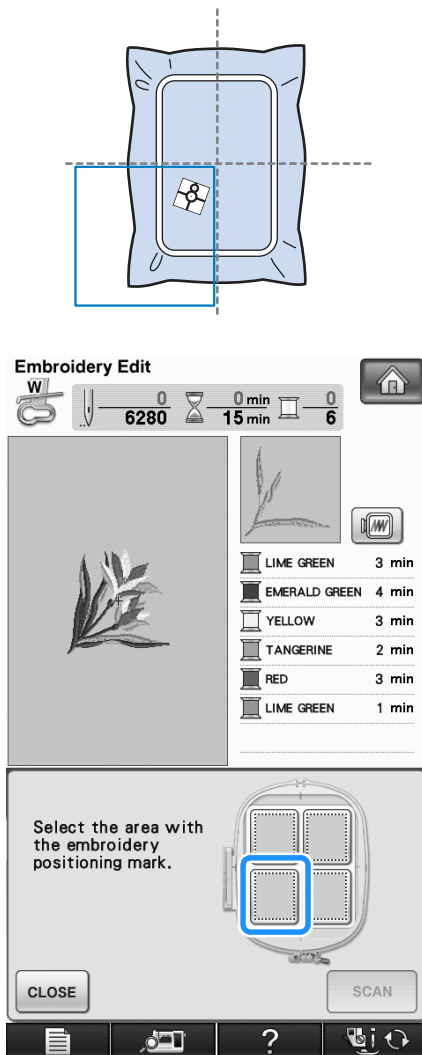

Note

- If the embroidery positioning sticker is placed in the center of embroidery frame, select any of the four areas.
- If the embroidery positioning sticker overlaps two areas, select either of the two areas.

- 4** Press **SCAN**.

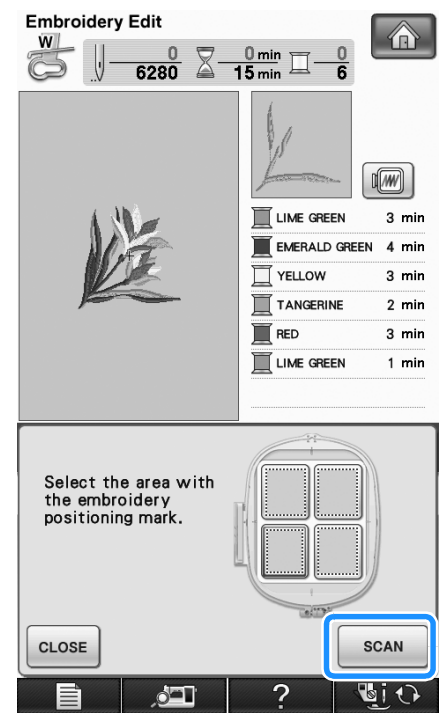

Note

- Attach embroidery foot “W” before pressing **SCAN**. The embroidery foot “W” lowers and check the fabric thickness, to help the built-in camera recognize the embroidery positioning sticker.

- 5** Following message appears. Press **OK**.



→ The built-in camera automatically searches for the embroidery positioning sticker, and then the carriage is moved so that the center of the embroidery pattern is aligned with the center of the embroidery positioning sticker. Regardless of the setting selected in the machine settings screen, the brightness of the light changes to “5” while the built-in camera searches for the embroidery positioning sticker.



Note

- If the following warning message appears, touch **CLOSE** and reposition the embroidery positioning sticker so the pattern is within the embroidery field, and then press **SCAN** again.

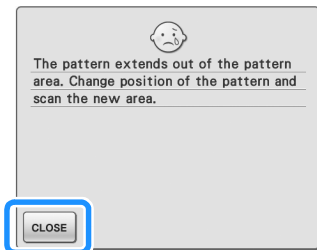

6 A reminder message appears. Remove the embroidery positioning sticker from the fabric and press **CLOSE**.

- * To remove the embroidery positioning sticker more easily, press  so that the embroidery frame moves slightly forward and away from under the needle. After the embroidery positioning sticker is removed, press **CLOSE**.

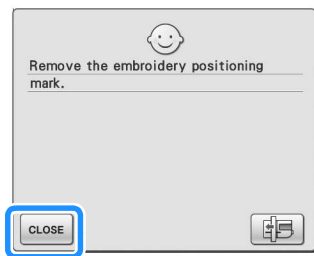
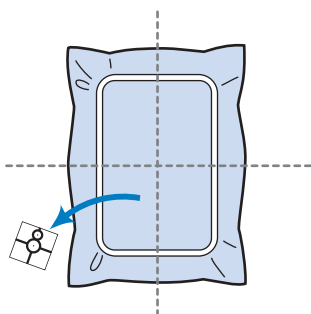

7 Press the “Start/Stop” button to begin embroidering.



Note

- After the included embroidery positioning stickers are used up, optional stickers are available. For details, refer to “Options” on page 8.

USING THE MEMORY FUNCTION

In the same way as embroidery patterns in Chapter 5, you can save and retrieve edited embroidery patterns to and from the machine's memory, a personal computer, or USB media. Refer to the relevant sections in Chapter 5 on saving and retrieving embroidery patterns and follow the same procedures in order to save and retrieve edited embroidery patterns.
See page 244 for more information about the MEMORY FUNCTION.

PRINT AND STITCH (COMBINING EMBROIDERY PATTERNS AND PRINTED DESIGNS)

Completed embroidery patterns combined with printed designs are built into this machine. Beautiful three-dimensional embroidered designs can be created by ironing a background onto fabric or printing it onto printable fabric, then sewing complementary embroidery on top of the background.

Using iron-on paper

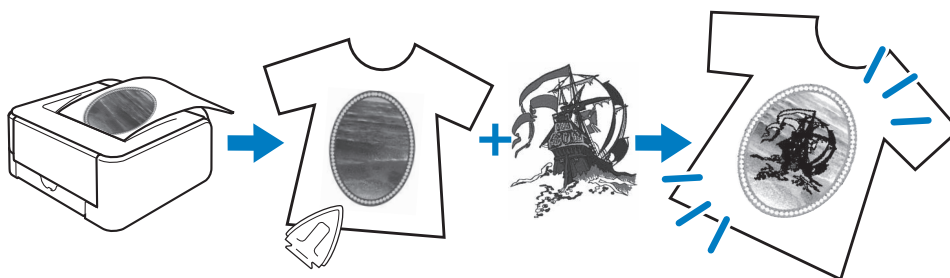

Using printable fabric

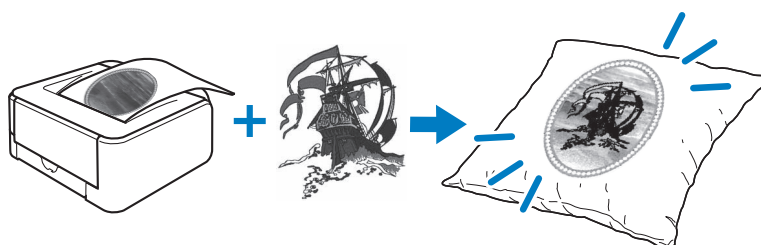

- | | |
|--------------|---|
| Step1 | Select a pattern to be combined with the background image.
→ See “Selecting a Pattern” on page 307. |
| ↓ | |
| Step2 | Output from the machine the background image and the positioning image.
→ See “Outputting the Background Image and Positioning Image” on page 308. |
| ↓ | |
| Step3 | When using iron-on paper
With a printer, print the background onto iron-on paper, and print the embroidery position sheet on plain paper. Then, iron the background image onto fabric.
When using printable fabric
With a printer, print the background onto printable fabric, and print the embroidery position sheet on plain paper.
→ See “Printing the Background and Embroidery Position Sheet” on page 310. |
| ↓ | |
| Step4 | Hoop in the embroidery frame the fabric with the background image ironed on or printed, check the embroidering position, and then start embroidering.
→ See “Sewing Embroidery Patterns” on page 310. |



Note

- Print the background and embroidery position sheet in their original dimensions. If an image is printed in a different size, the sizes of the embroidery pattern and background may not match. In addition, the built-in camera cannot detect the embroidery position mark. Make sure that the print settings are correctly specified.

Selecting a Pattern

Patterns combining embroidery and printed designs can be selected from the pages that contain . Select the desired pattern.

Memo

- Refer to the Quick Reference Guide for the detail of patterns which enable this function.

- 1 Press the key of the pattern you want to embroider.

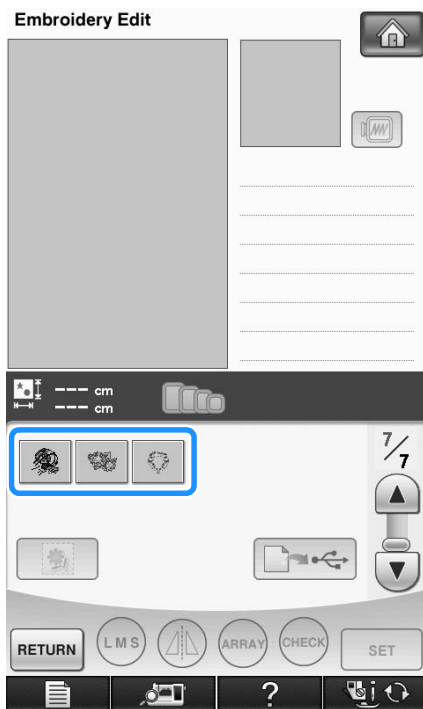

→ An image of the pattern combined with the background appears.

■ Checking Only the Embroidery Pattern

Press .



→ Only the embroidery pattern (not the background image of the selected embroidery pattern) is displayed.

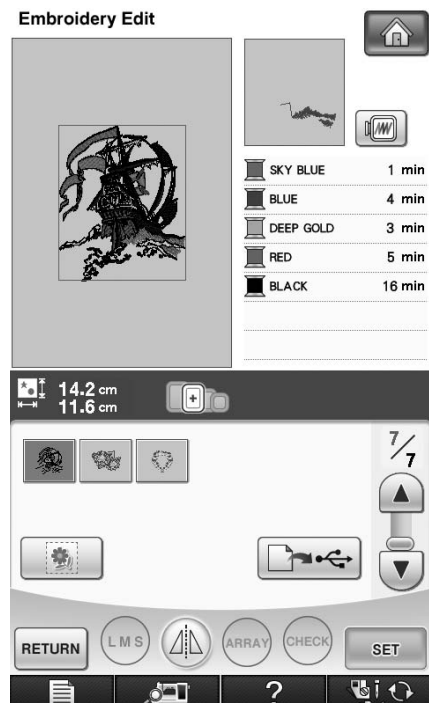

* To return to the image of the pattern combined with the background, press .

Outputting the Background Image and Positioning Image

Use USB media or the computer to output the following three images from the machine.

* File name may differ depending on the PDF file selected.

- **[xxx]r.pdf (Example: E_1r.pdf)**
An image flipped on a vertical axis (for an iron-on transfer)



- **[xxx]n.pdf (Example: E_1n.pdf)**
An image that is not flipped (for printing on printable fabric)

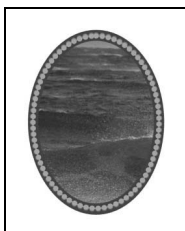

- **[xxx]p.pdf (Example: E_1p.pdf)**
An image that is not flipped, but has positioning marks attached (for positioning)

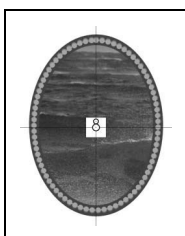

Note

- Print the background and embroidery position sheet in their original dimensions. If an image is printed in a different size, the sizes of the embroidery pattern and background may not match. In addition, the built-in camera cannot detect the embroidery position mark. Make sure that the print settings are correctly specified.
- When printing the PDF file of the image with positioning marks, specify the highest image quality possible for full-color printing. In addition, use matte printing paper. Due to poor printing conditions, the machine's built-in camera may not be able to correctly detect the positioning marks. (For details on printing, refer to the operating instructions for your printer.)

Using USB Media

- 1 Insert the USB media into the primary (top) USB port on the machine.
- 2 Select the pattern, and then press .



→ The select USB output screen appears.

- 3 Press  to select the primary (top) USB port where the primary USB media is inserted.

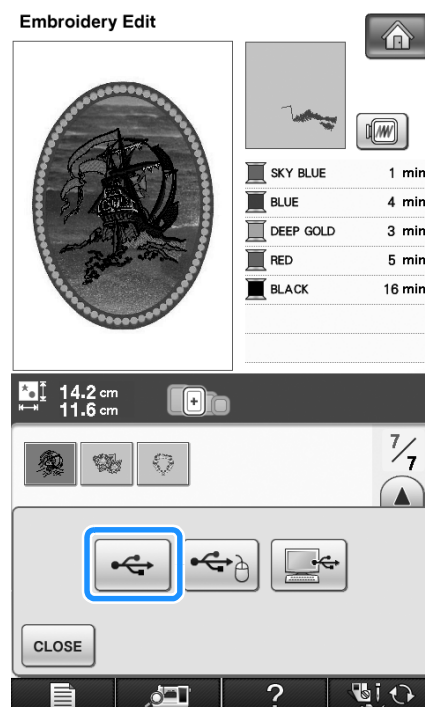

→ Two files of the background image only and one file for aligning embroidery into position are copied (PDF format) onto the USB media.

Memo

- Do not remove the USB media from the machine until data output is finished.

4 Remove the USB media where the image data is saved from the machine, and then copy the image data from the USB media to the computer.

Using a USB Cable

1 Plug the USB cable connectors into the corresponding USB ports on the computer and on the machine.

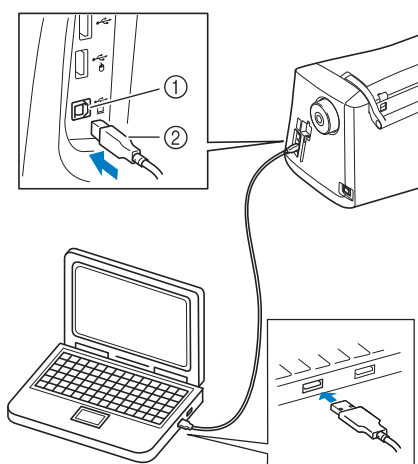

- ① USB port for computer
 - ② USB cable connector
- The "Removable Disk" icon appears in "Computer (My computer)" on the computer.

2 Select the pattern, and then press



→ The select USB output screen appears.

3 Press



→ Two files of the background image and one file for aligning embroidery into position are copied (PDF format) into "Removable Disk" under "Computer (My computer)".

Memo

- Do not disconnect the USB cable from the machine until data output is finished.

4 Copy the image data saved in "Removable Disk" into a different file before closing.

Printing the Background and Embroidery Position Sheet

Print the PDF files of the background and embroidery position sheet. The background file that is printed differs depending on whether iron-on paper or printable fabric is used.

To view the PDF file, Adobe® Reader® is needed. If it is not installed on your computer, you can download it from the Adobe Systems website: <http://www.adobe.com/>

- 1 **Open the PDF file to be printed, click “File”-“Print”, and then set “Page Scaling” to “None (100%)”.**



Note

- Print the background and embroidery position sheet in their original dimensions. If an image is printed in a different size, the sizes of the embroidery pattern and background may not match. In addition, the built-in camera cannot detect the embroidery position mark. Make sure that the print settings are correctly specified.

- 2 **Print the background image.**

- * When printing onto iron-on paper, print the file named E_1r.pdf (an image flipped on a vertical axis). When printing onto printable fabric, print the file named E_1n.pdf (an image that is not flipped).

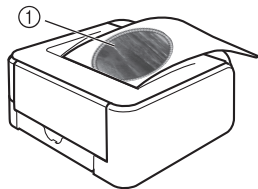

① Background image



Note

- Before printing onto iron-on paper or printable fabric, we recommend performing a test print to check the print settings.
- For details on printing on iron-on transfer sheets or printable fabric, refer to the instructions for the iron-on transfer sheets and printable fabric.
- Some printers will automatically print an image flipped if an iron-on transfer sheet is selected as the paper. For details, refer to the instructions for the printer being used.

- 3 **Print the embroidery position sheet (file named E_1p.pdf) onto plain paper.**

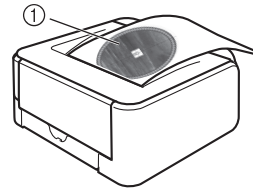

① Embroidery position sheet



Note

- When printing the PDF file for the embroidery position sheet, specify the highest image quality possible for full-color printing. In addition, we recommend printing on matte paper. If this is not done, the built-in camera may not be able to correctly detect the embroidery positioning mark.

- 4 **If an iron-on transfer sheet is used, transfer the image onto fabric.**





Memo

- For details on transferring from iron-on transfer sheets, refer to the instructions for the iron-on transfer sheets.
- If necessary, cut the iron-on transfer sheet to the size of the pattern before transferring the image.

Sewing Embroidery Patterns

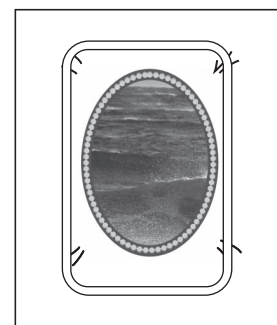
- 1 **Hoop in the embroidery frame the fabric with the background image ironed on.**



- 2 Cut the paper printed with the center positioning image  so it can easily be positioned aligned with the background image on the fabric.

* Lines or color changes in the image can help you find the correct alignment position.

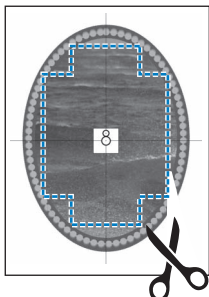

- 3 Place the paper printed with the positioning image on top of the fabric so that the pattern is aligned, and then affix the paper to the fabric with cellophane tape to prevent the paper from moving.

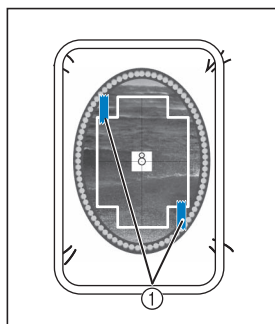

① Cellophane tape

- 4 After checking that a pattern is selected, press  .

→ The sewing screen appears.



Note

- Before embroidering, check that the embroidery position sheet is perfectly aligned with the background.

- 5 Align the embroidering position according to steps 2 through 6 of “Using the Built-In Camera to Align the Embroidering Position” on page 302.

- 6 Remove the positioning sheet and press the “Start/Stop” button to begin embroidering.

! CAUTION

- Before pressing the “Start/Stop” button to begin embroidering, remove the positioning sheet taped to the fabric in step 3.



Chapter 7

MY CUSTOM STITCH

DESIGNING A STITCH.....	314
ENTERING STITCH DATA	316
■ Key Functions	316
■ Moving a Point	319
■ Moving Part or All of the Design	319
■ Inserting New Points	320
USING STORED CUSTOM STITCHES	322
Storing Custom Stitches in Your List	322
■ If the Memory is Full	322
Retrieving Stored Stitches	323

DESIGNING A STITCH

By using the MY CUSTOM STITCH™ function, you can register stitches you have created yourself. You can also sew designs combining MY CUSTOM STITCH™ creations with built-in characters (see page 162).

Memo

- Stitches that you create with MY CUSTOM STITCH™ can be a maximum of 7 mm (approx. 9/32 inch) wide and 37 mm (approx. 1-1/3 inches) long.
- Stitches can be designed more easily with MY CUSTOM STITCH™ if you first draw the stitch on the included grid sheet.

1 Draw the stitch design on the grid sheet (part code SA507, X81277-151).

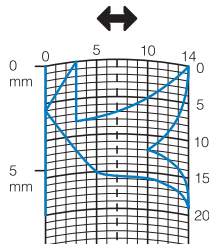

Memo

- Simplify the design so that it can be sewn as a continuous line. For a more attractive stitch, close the design by intersecting lines.

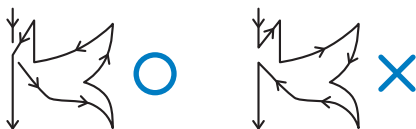

If the design is to be repeated and linked, the start point and end point of the design should be at the same height.



2 Decide the spacing of the stitch.

- * By adjusting the spacing of a stitch, you can create various patterns with one stitch.

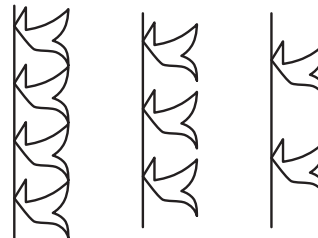
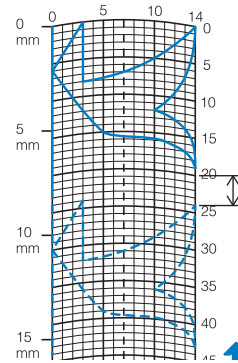

3 Place points where the pattern intersects with the grid, and connect all the points with a line.

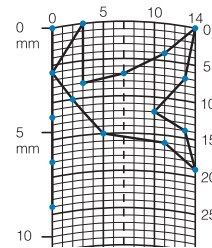

4 Determine the x and y coordinates of each of the marked points.

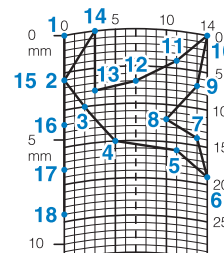

Memo

- This will determine the stitch design that will be sewn.

Examples of Custom Stitches

	Stitch	1	2	3	4	5	6	7	8	9	10	11	12	13	14	15
	↕	0	12	18	22	23	21	17	14	12	9	6	3	1	3	6
	↔	0	0	3	6	10	13	14	13	11	13	14	13	10	6	3
	Stitch	16	17	18	19	20	21	22	23	24	25	26	27	28	29	30
	↕	12	41	43	40	41	38	35	32	30	32	35	41	45	47	44
	↔	0	0	4	7	11	13	14	13	10	6	3	0	0	4	7
	Stitch	31	32	33	34	35	36	37	38	39	40	41	42	43	44	45
	↕	45	47	50	54	56	55	51	45	70						
↔	11	13	14	13	10	6	3	0	0							

	Stitch	1	2	3	4	5	6	7	8	9	10	11	12	13	14	15
	↕	0	30	32	32	32	33	35	35	37	35	32	30	30	29	26
	↔	0	0	1	7	10	12	11	8	12	14	14	11	5	3	8
	Stitch	16	17	18	19	20	21	22	23	24	25	26	27	28	29	30
	↕	24	18	13	12	13	10	12	8	12	7	12	6	10	5	10
	↔	10	13	14	14	12	11	10	9	8	6	6	3	2	0	2
	Stitch	31	32	33	34	35	36	37	38	39	40	41	42	43	44	45
	↕	16	19	23	22	17	22	23	19	42						
↔	1	0	0	6	10	6	0	0	0							

	Stitch	1	2	3	4	5	6	7	8	9	10	11	12	13	14	15
	↕	0	3	5	8	12	17	20	24	27	29	31	32	30	27	24
	↔	0	5	8	11	13	14	14	13	12	11	9	6	3	1	0
	Stitch	16	17	18	19	20	21	22	23	24	25	26	27	28	29	30
	↕	21	18	16	15	15	16	18	21	25	28	33	37	41	43	44
	↔	0	1	3	5	8	10	12	13	14	14	13	11	8	5	0
	Stitch	31	32	33	34	35	36	37	38	39	40	41	42	43	44	45
	↕															
↔																

	Stitch	1	2	3	4	5	6	7	8	9	10	11	12	13	14	15
	↕	0	5	4	5	8	7	8	11	11	11	16	11	7	4	0
	↔	7	7	3	7	7	0	7	7	3	7	7	3	0	3	7
	Stitch	16	17	18	19	20	21	22	23	24	25	26	27	28	29	30
	↕	4	7	11	16	21	20	21	24	23	24	27	27	27	32	27
	↔	11	14	11	7	7	11	7	7	14	7	7	11	7	7	11
	Stitch	31	32	33	34	35	36	37	38	39	40	41	42	43	44	45
	↕	23	20	16	20	23	27	32								
↔	14	11	7	3	0	3	7									



ENTERING STITCH DATA

Key Functions

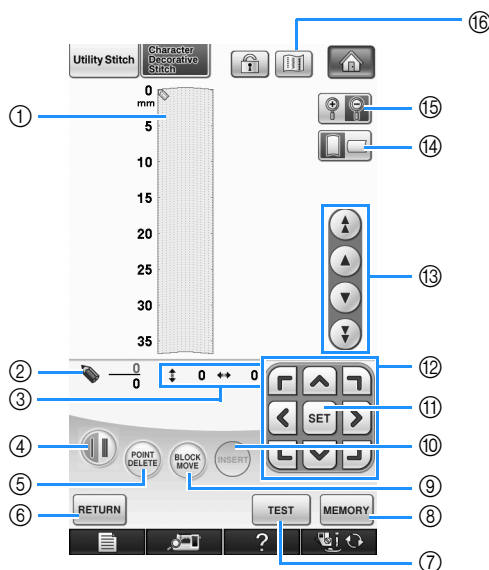



- ① This area displays the stitch being created.
- ② Displays the number of the present set point over the total number of points in the stitch.
- ③ Displays the y-coordinate of over the x-coordinate of .

No.	Display	Key Name	Explanation	Page
④		Single/triple stitching key	Press this key to select whether one or three stitches will be sewn between two points.	318
⑤		Point delete key	Press this key to delete a selected point.	318
⑥		Return key	Press this key to exit the entering stitch data screen.	—
⑦		Test key	Press this key to SEW a test of the stitch.	318, 322
⑧		MY CUSTOM STITCH™ memory key	Press this key to store the stitch being created.	322
⑨		Block move key	Press this key to group points together and move them together.	319
⑩		Insert key	Press this key to insert new points on the stitch design.	320
⑪		Set key	Press this key to set a point on the stitch design.	317-319
⑫		Arrow keys	Use these keys to move over the display area.	317-321
⑬		Point-to-point key	Use these keys to move from point to point on the stitch, or to the first or last point entered on the stitch.	319-320
⑭		Grid direction key	Press this key to change the direction of the grid sheet.	317
⑮		Enlarger key	Press this key to see an enlarged version of the stitch being created.	317
⑯		Image key	Press this key to view an image of the stitch.	318

1 Press  and then .

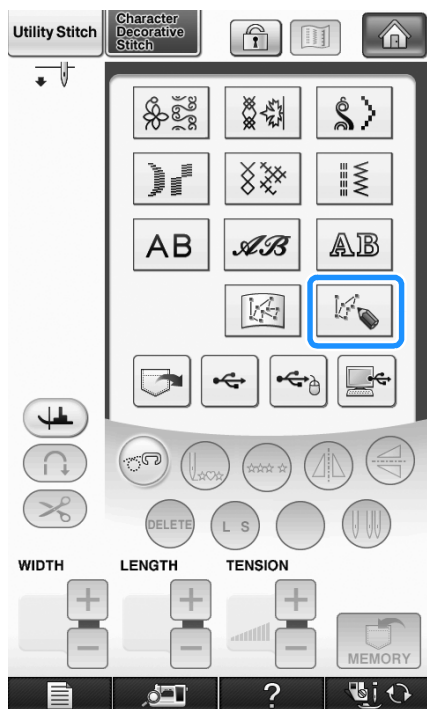
2 Press .



3 Use  to move  to the coordinates of the first point on the grid sheet.

* Press  to change the direction of the grid sheet.

* Press  to enlarge the image of the stitch being created.

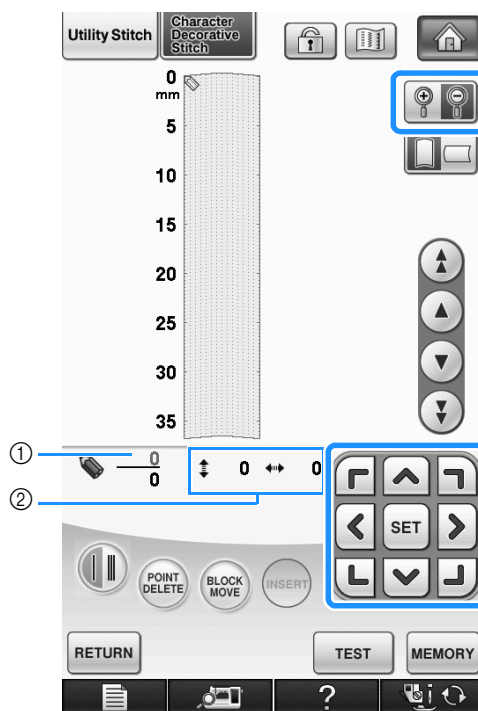

- ① Currently selected point/Total number of points
- ② Coordinates of 

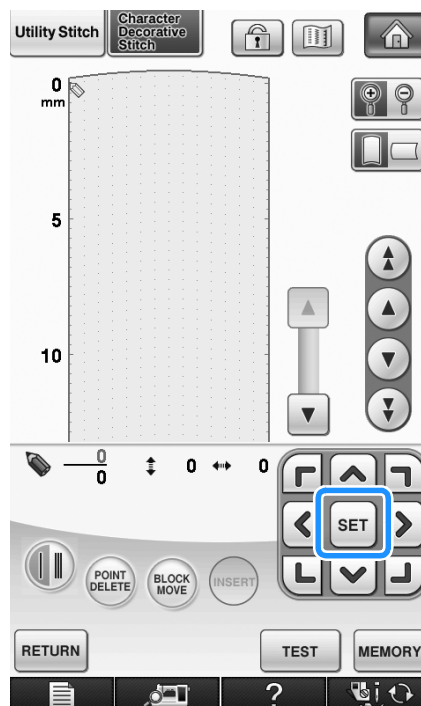

4 Press  to add the point indicated by .

* To insert coordinates with the touch pen, move the tip of the pen to a desired point. Once you release the pen from the screen a point will be entered into the graph at those coordinates. The number of the currently selected points along with the total number of points will be displayed.





5 Select whether one stitch or three stitches will be sewn between the first two points.

* To sew three stitches, press the key so that it appears as .

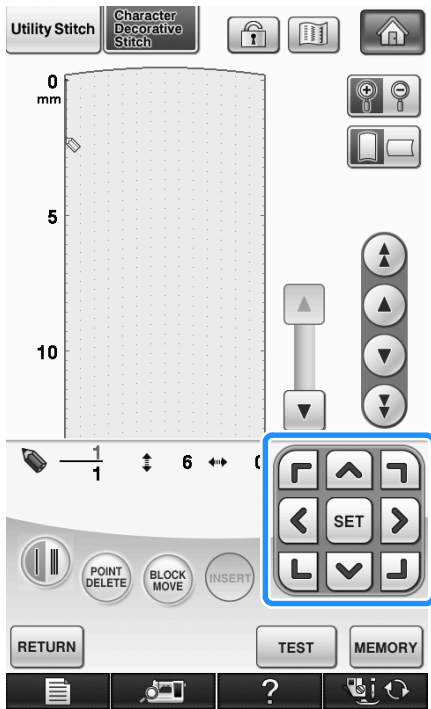
6 Use  to move  to the second point and press .



7 Repeat the steps above for each point that you have drawn on the grid sheet until the stitch design is drawn on the screen as a continuous line.

- * Press  to delete a selected point entered.
- * Press  to sew a test-run of the stitch.
- * Press  to return to the original screen.

* Press  to view an image of the stitch.

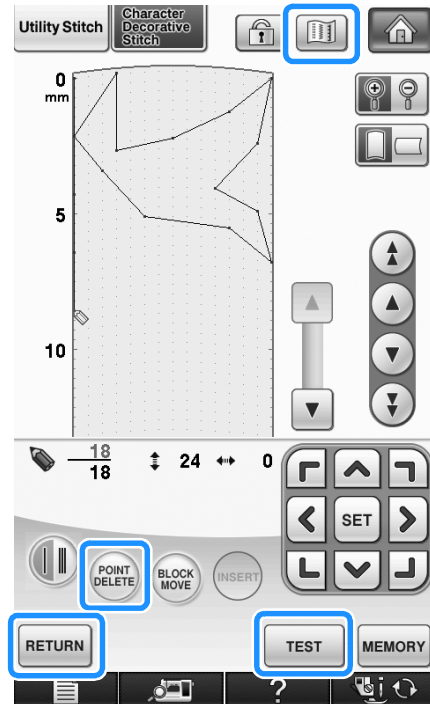

 **Memo**

- If you have entered points that are too close together, the fabric may not feed properly. Edit the stitch data to leave a larger space between points.
- If the stitch design is to be repeated and linked, make sure that linking stitches are added so that the stitch designs will not overlap.

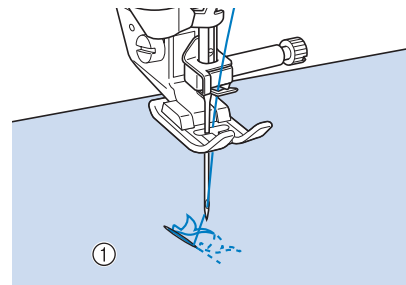

① Linking stitches

- You can touch on the grid sheet to set the point, or you can also use a USB mouse.

■ Moving a Point

1 Press or to move to the point that you want to move.

- * To move to the first point, press .
- * To move to the last point, press .
- * You can also move by using the touch pen.

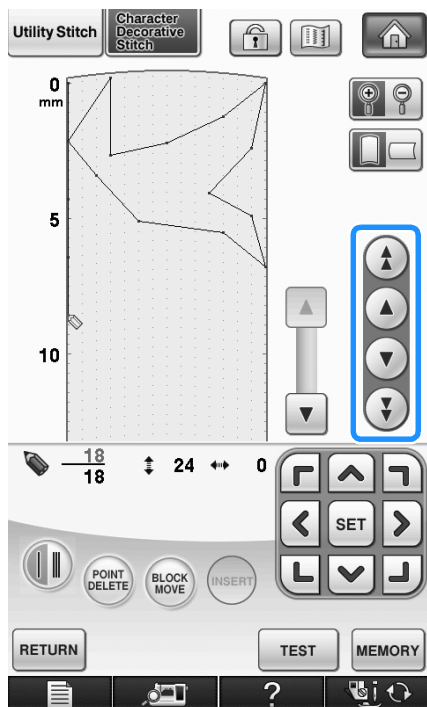

2 Use to move the point.

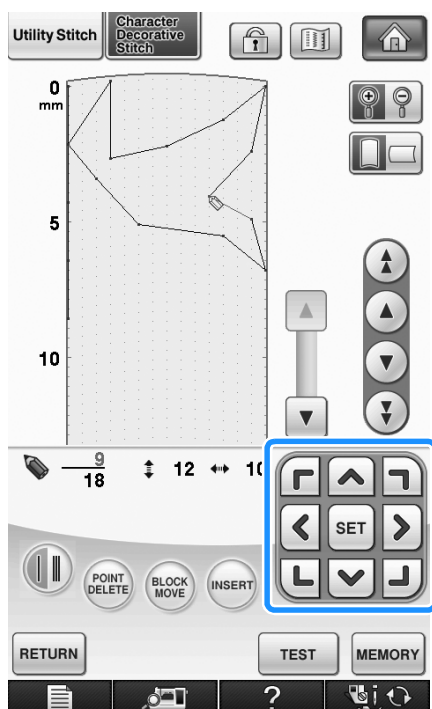

■ Moving Part or All of the Design

1 Press or to move to the first point of the section that you want to move.

- * To move to the first point, press .
- * To move to the last point, press .
- * You can also move by using the touch pen.

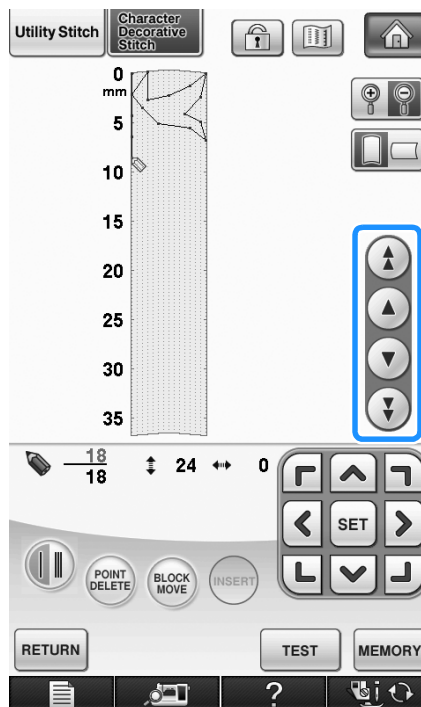

2 Press .

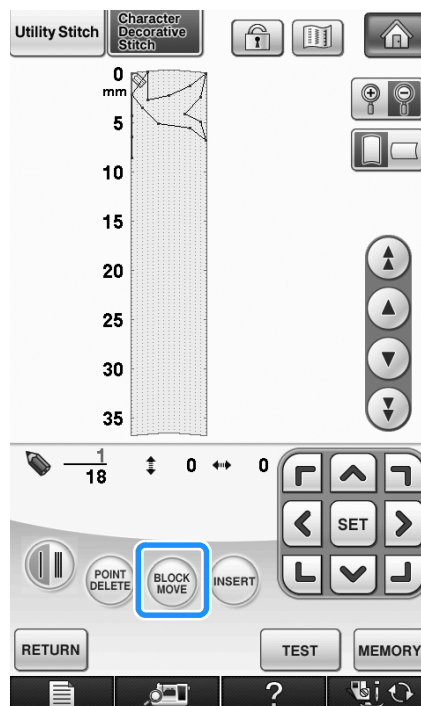

→ The selected point and all points that were entered after it are selected.

3 Press or to move the section.

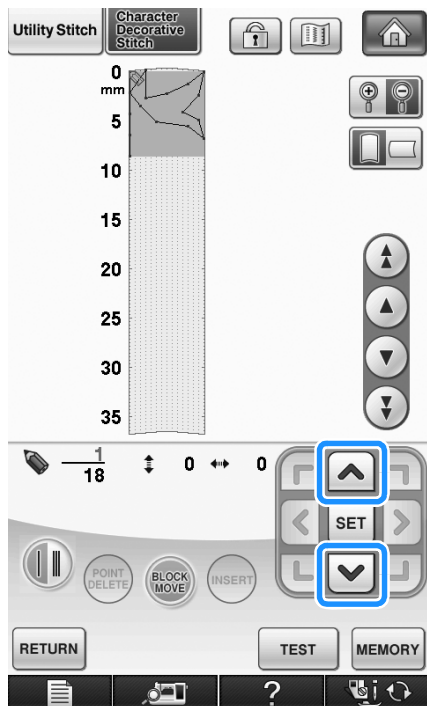

4 Press .

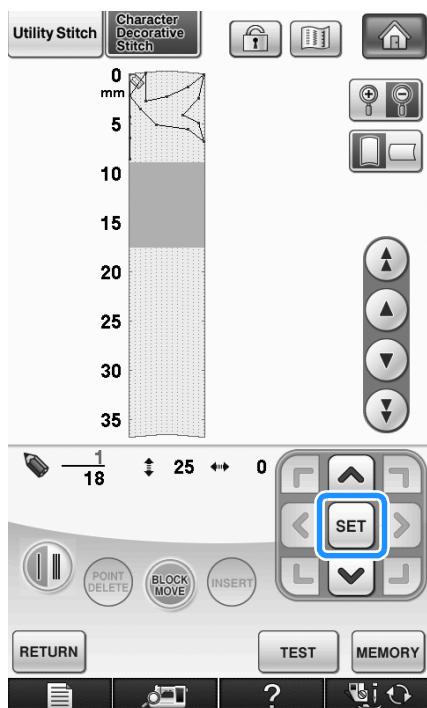

→ The section will be moved.

■ Inserting New Points

1 Press or to move to a place on the design where you want to add a new point.

- * To move to the first point, press .
- * To move to the last point, press .
- * You can also move by using the touch pen.

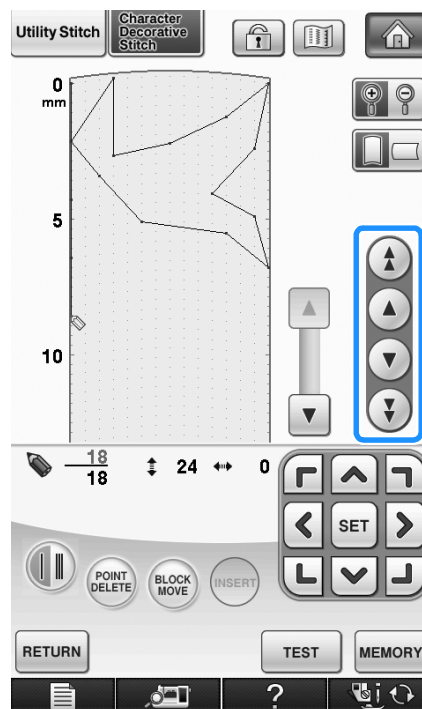

2 Press .

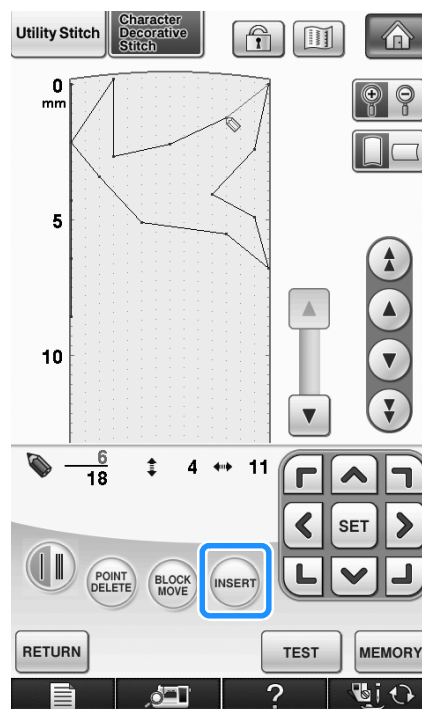

→ A new point is entered and  moves to it.

3 Use  to move the point.

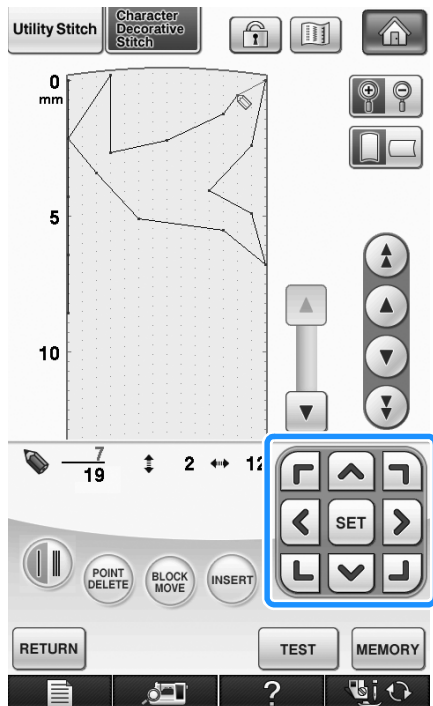

USING STORED CUSTOM STITCHES

Storing Custom Stitches in Your List

Stitch patterns created using the MY CUSTOM STITCH™ function can be stored for later use. Once you finish entering the stitch data, press **MEMORY**. The “Saving” message appears and the stitch will be stored.

Before storing a stitch, press **TEST** to sew a test-run of the stitch.

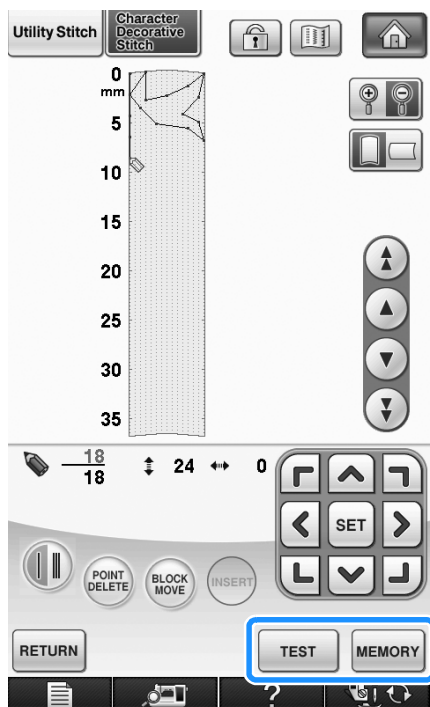

Memo

- Storing a stitch pattern takes a few seconds.
- For details on retrieving a stored stitch pattern, see page 323.

Note

- Do not turn off the machine while the “Saving” message is displayed, otherwise the stitch pattern data being saved may be lost.

■ If the Memory is Full

If the following message appears after **MEMORY** is pressed, the stitch pattern cannot be stored because either the machine’s memory is full or the stitch pattern being stored is larger than the amount of space available in the memory. To be able to store the stitch pattern in the machine’s memory, a previously stored stitch pattern must be deleted.

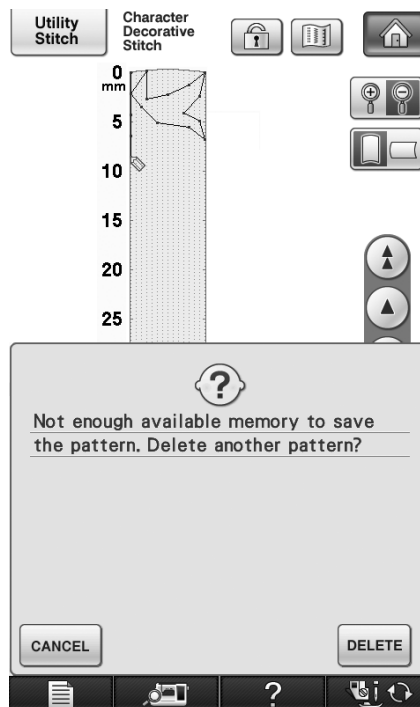

Note

- To save custom stitches to USB media or in the computer, follow the previously described procedure to store the custom stitch, and then press **MEMORY** to select the stitch (see the following “Retrieving Stored Stitches” section). Press **MEMORY** to save the stitch to USB media or in the computer. (For details, “Saving Stitch Patterns to USB Media” on page 174 or “Saving Stitch Patterns in the Computer” on page 175.)

Retrieving Stored Stitches

1 Press  .

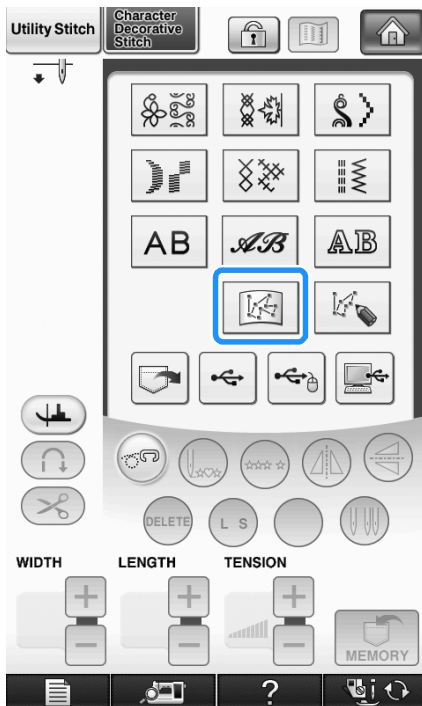



→ A list of stored stitch patterns is displayed.

2 Select the stitch pattern.

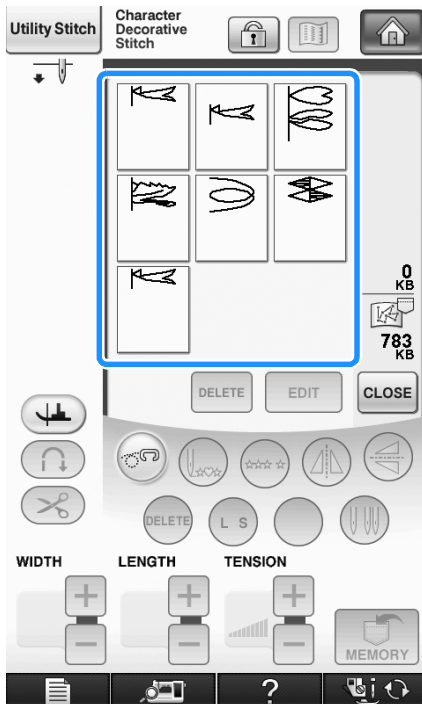
* Press  to return to the previous screen without retrieving.



3 Press  .

- * To delete the stored stitch pattern, press  .
- * To edit the stored stitch pattern, press  .

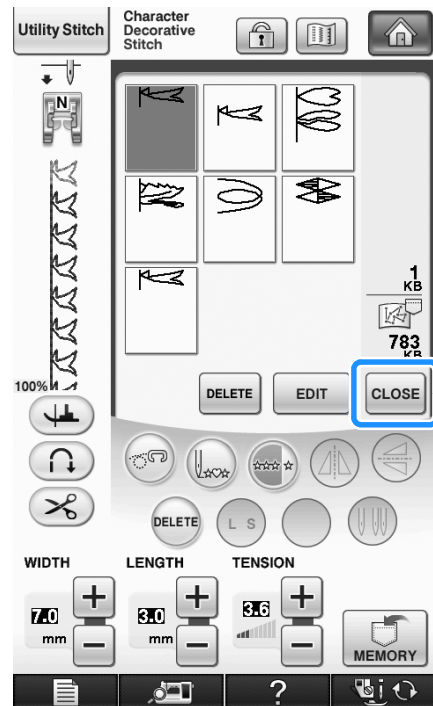



Chapter 8

Appendix

CARE AND MAINTENANCE	326
Cleaning the LCD Screen	326
Cleaning the Machine Casing	326
Cleaning the Race	326
Cleaning the Cutter in the Bobbin Case Area	327
About the Maintenance Message.....	328
ADJUSTING THE SCREEN	329
Touch Panel is Malfunctioning	329
TROUBLESHOOTING	330
ERROR MESSAGES	335
■ Alarm Sounds	342
SPECIFICATIONS	343
UPGRADING YOUR MACHINE'S SOFTWARE	344
Upgrade Procedure Using USB Media	344
Upgrade Procedure Using Computer	345
STITCH SETTING CHART	347
INDEX	356

CARE AND MAINTENANCE

⚠ CAUTION

- Be sure to unplug the machine before cleaning it. Otherwise, electric shock or injury may result.

Cleaning the LCD Screen

If the screen is dirty, gently wipe it with the included LCD cleaning cloth or a soft, dry cloth. Do not use organic solvents or detergents.



Note

- Do not wipe the LCD screen with a damp cloth.



Memo

- Occasionally, condensation may form on the LCD screen or it may become fogged up; however, this is not a malfunction. After a while, the cloudiness will disappear.

Cleaning the Machine Casing

If the surface of the machine is dirty, lightly soak a cloth in a neutral detergent, squeeze it out firmly, and then wipe the surface. Then wipe again with a dry cloth.

Cleaning the Race

If dust or bits of dirt collect in the race or bobbin case, the machine will not run well, and the bobbin thread detection function may not operate. Keep the machine clean for best results.

Press **?** → **Operation Guide** → **Maintenance** →

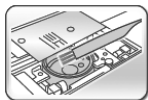

→  in this order to display a

video example of cleaning the race (see page 34). Follow the steps explained below to complete the operation.

- 1 Press the “Needle Position” button to raise the needle.
- 2 Turn the main power to OFF.
- 3 Remove the needle and the presser foot holder (see pages 55 through 56).
- 4 Remove the flat bed attachment or the embroidery unit if either is attached.
- 5 Grasp both sides of the needle plate cover, and then slide it toward you.

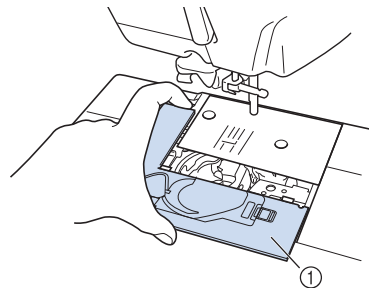

① Needle plate cover
→ The needle plate cover is removed.

- 6 Grasp the bobbin case, and then pull it out.

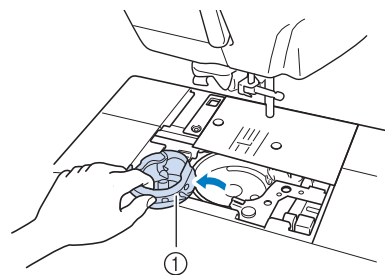

① Bobbin case

- 7** Use the cleaning brush or a vacuum cleaner to remove any lint and dust from the race and bobbin thread sensor and the surrounding area.

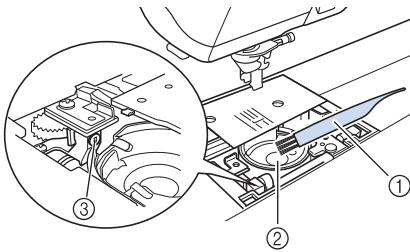

- ① Cleaning brush
② Race
③ Bobbin thread sensor

**Note**

- Do not apply oil to the bobbin case.
- If lint or dust collects on the bobbin thread sensor, the sensor may not operate correctly.

- 8** Insert the bobbin case so that the projection on the bobbin case aligns with the spring.

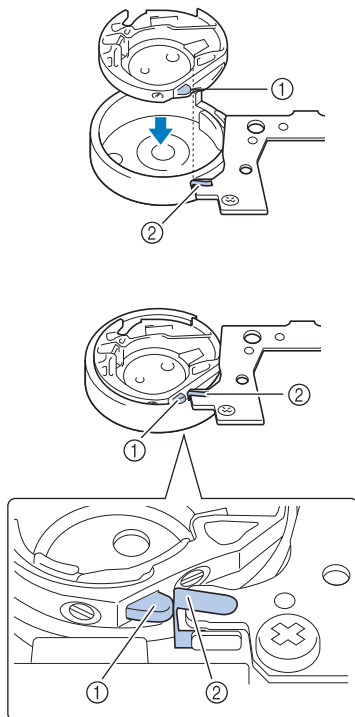

- ① Projection
② Spring

CAUTION

- Be sure that the bobbin case is correctly installed. Otherwise, the needle may break.

- 9** Insert the tabs on the needle plate cover into the needle plate, and then slide the cover back on.

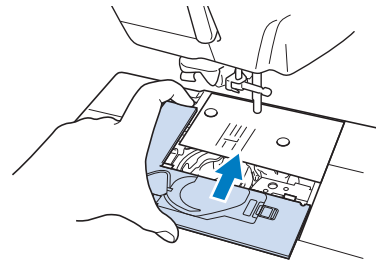
**Note**

- Never use a bobbin case that is scratched; otherwise, the upper thread may become tangled, the needle may break, or sewing performance may suffer. For a new bobbin case (part code: XC3153-251 (green marking on the screw), XC8167-451 (no color on the screw)), contact your nearest authorized service center.
- If the needle plate has been removed it is especially important to reinstall the needle plate and tighten the screws prior to installing the bobbin case.

Cleaning the Cutter in the Bobbin Case Area

The cutter below the needle plate should be cleaned. If dust or lint accumulate on the cutter, it will be difficult to cut the thread when the "Thread Cutter" button is pressed or the automatic thread cutting function is used. Clean the cutter when the thread is not easily cut.

- 1** Follow steps ① through ⑤ in "Cleaning the Race" to remove the needle plate cover.
- 2** Use the screwdriver included with the machine to unscrew and remove the needle plate.

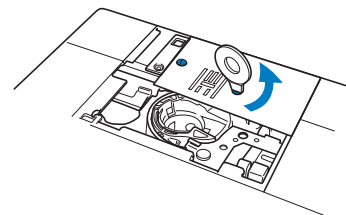

- 3 Use the cleaning brush or a vacuum cleaner to remove any lint and dust from the cutter in the bobbin case area.

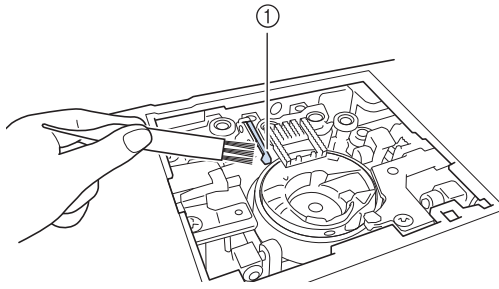

① Cutter

CAUTION

- Do not touch the cutter, otherwise injuries may result.

- 4 Use the screwdriver included with the machine to screw and attach the needle plate.

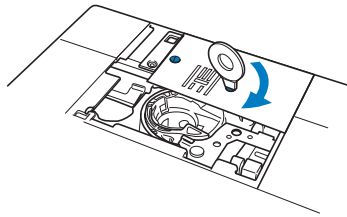

- 5 Insert the tabs on the needle plate cover into the needle plate, and then slide the cover back on.

About the Maintenance Message



Once this message appears, it is recommended to take your machine to an authorized dealer or nearest authorized service center for a regular maintenance check. Although this message will disappear and the machine will continue to function once you press , the message will display several more times until the appropriate maintenance is performed.

Please take the time to arrange the maintenance your machine requires once this message appears. Such steps will help to ensure you receive continued, uninterrupted hours of machine operation for the future.

ADJUSTING THE SCREEN

Touch Panel is Malfunctioning

If the screen does not respond correctly when you touch a key (the machine does not perform the operation or performs a different operation), follow the steps below to make the proper adjustments.

- 1 **Holding your finger on the screen, turn the main power switch to OFF and back to ON.**

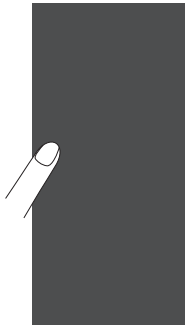

→ The touch panel adjustment screen is displayed.

- 2 **Using the included touch pen, lightly touch the center of each +, in order from 1 to 5.**



Note

- Only use the included touch pen to touch the screen. Do not use a mechanical pencil, pin, or other sharp object. Do not press strongly on the screen. Otherwise, damage may result.

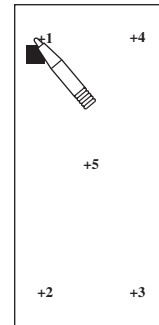



- 3 **Turn the main power to OFF, then turn it back to ON.**





Note

- If you finish the screen adjustment and the screen still does not respond, or if you cannot do the adjustment, contact your authorized dealer.

TROUBLESHOOTING





If you have a minor problem with your sewing machine, check the following solutions. If the solutions suggested do not correct the problem, contact your authorized dealer. Press  →  →

 for advice about minor sewing problems during sewing. Press  at any time to return to the original screen. If you need additional help, the Brother Solutions Center offers the latest FAQs and troubleshooting tips. Visit us at [<http://solutions.brother.com>]. If the problem persists, contact your dealer or the nearest authorized service center.

Problem	Cause	Solution	Page
The thread is tangled on the wrong side of the fabric.	Upper threading is incorrect.	Check the steps for threading the machine and rethread the machine.	46
	Using improper needle or thread for the selected fabric.	Check the "Fabric/Thread/Needle Combinations" chart.	58
The upper thread is too tight.	The bobbin thread is incorrectly installed.	Correctly install the bobbin thread.	43
Cannot thread the needle	Needle is not in the correct position.	Press the "Needle Position" button to raise the needle.	3
	Needle is installed incorrectly.	Reinstall the needle correctly.	56
	Needle is turned, bent or the point is dull.	Replace the needle.	56
Cannot lower the presser foot with the presser foot lever	Presser foot was raised using the "Presser Foot Lifter" button.	Press the "Presser Foot Lifter" button to lower the presser foot.	3
Thread tension is incorrect	Upper threading is incorrect.	Check the steps for threading the machine and rethread the machine.	46
	Bobbin is set incorrectly.	Reset the bobbin. (If needle plate was removed, reinstall needle plate and tighten screws prior to installing bobbin case.)	43
	Using improper needle or thread for the selected fabric.	Check the "Fabric/Thread/Needle Combination" chart.	58
	Presser foot holder is not attached correctly.	Reattach the presser foot holder correctly.	55
	Thread tension is set incorrectly.	Adjust the thread tension.	67, 227
	Bobbin thread is incorrectly wound.	Use a correctly wound bobbin.	37
	Needle is turned, bent or the point is dull.	Replace the needle.	56
Upper thread breaks	Machine is not threaded correctly (used the wrong spool cap, spool cap is loose, the thread did not catch the needle bar threader, etc.)	Rethread the machine correctly.	46
	Needle is turned, bent or the point is dull.	Replace the needle.	56
	There are scratches on the race.	Replace the race, or consult your authorized dealer.	326
	Upper thread tension is too strong.	Adjust the thread tension.	67, 227
	Using improper needle or thread for the selected fabric.	Check the "Fabric/Thread/Needle Combinations" chart.	58
	Thread is twisted.	Use scissors, etc., to cut the twisted thread and remove it from the race, etc.	—
	There are scratches near the hole of the needle plate.	Replace the needle plate, or consult your authorized dealer.	86
	There are scratches near the hole in the presser foot.	Replace the presser foot, or consult your authorized dealer.	54
	Needle is installed incorrectly.	Reinstall the needle correctly.	56
	Thread is knotted or tangled.	Rethread upper and lower thread.	43, 46
	A bobbin designed specifically for this machine is not used.	Incorrect bobbins will not work properly. Only use a bobbin designed specifically for this machine.	43

Problem	Cause	Solution	Page
Bobbin thread breaks	Bobbin is set incorrectly.	Reset the bobbin thread correctly.	43
	There are scratches on the bobbin or it doesn't rotate properly.	Replace the bobbin.	43
	Thread is twisted.	Use scissors, etc. to cut the twisted thread and remove it from the race, etc.	—
	A bobbin designed specifically for this machine is not used.	Incorrect bobbins will not work properly. Only use a bobbin designed specifically for this machine.	43
Bobbin thread does not wind neatly on the bobbin.	The thread is not passed through the bobbin winding thread guide correctly.	Correctly pass the thread through the bobbin winding thread guide.	38
	Bobbin spins slowly.	Press [+] in the bobbin winding window to increase the bobbin winding speed.	39
	The thread that was pulled out was not wound onto the bobbin correctly.	Wind the thread that was pulled off around the bobbin 5 or 6 times clockwise.	39
Skipped stitches	Needle is turned, bent or the point is dull.	Replace the needle.	56
	Using improper needle or thread for the selected fabric.	Check the "Fabric/Thread/Needle Combination" chart.	58
	Machine is threaded incorrectly.	Check the steps for threading the machine and rethread it correctly.	46
	Dust or lint has collected under the needle plate.	Remove the dust or lint with the brush.	326
	Needle is installed incorrectly.	Reinstall the needle correctly.	56
	Needle is defective.	Replace the needle.	56
	Thin or stretch fabrics are being sewn.	Sew with one sheet of thin paper under the fabric.	64
Needle breaks	Needle is installed incorrectly.	Reinstall the needle correctly.	56
	Needle clamp screw is not tightened.	Tighten the needle clamp screw.	57
	Needle is turned or bent.	Replace the needle.	56
	Using improper needle or thread for the selected fabric.	Check the "Fabric/Thread/Needle Combination" chart.	58
	Wrong presser foot was used.	Use the recommended presser foot.	"STITCH SETTING CHART"
	Upper thread tension is too strong.	Adjust the thread tension setting.	67, 227
	Fabric is pulled during sewing.	Do not pull the fabric during sewing.	—
	Spool cap is set incorrectly.	Check the method for attaching the spool cap, then reattach the spool cap.	46
	There are scratches around the holes in the needle plate.	Replace the needle plate, or consult your authorized dealer.	86
	There are scratches around the hole(s) in the presser foot.	Replace the presser foot, or consult your authorized dealer.	54
	There are scratches on the race.	Replace the race, or consult your authorized dealer.	326
	Needle is defective.	Replace the needle.	56
	Upper threading is incorrect.	Check the steps for threading the machine and rethread the machine.	46
	Bobbin is set incorrectly.	Reset the bobbin thread correctly.	43
	Presser foot is attached incorrectly.	Attach the presser foot correctly.	54
	Screw of the presser foot holder is loose.	Securely tighten the screw of the presser foot.	55
	Fabric is too thick.	Use fabric that the needle can pierce when the handwheel is turned.	63
	Fabric is fed forcefully when sewing thick fabric or thick seams.	Allow the fabric to be fed without being forcefully pushed.	
	Stitch length is too short.	Adjust the stitch length.	67
	Stabilizer is not attached to fabric being embroidered.	Attach stabilizer.	152, 198
Bobbin thread is incorrectly wound.	Use a correctly wound bobbin.	37	

Problem	Cause	Solution	Page
Fabric does not feed through the machine	Feed dogs are set in the down position.	Press  , and then turn the handwheel to raise the feed dogs.	105
	Stitches are too close together.	Lengthen the stitch length setting.	67
	Wrong presser foot was used.	Use the correct presser foot.	"STITCH SETTING CHART"
	Needle is turned, bent or the point is dull.	Replace the needle.	56
	Thread is entangled.	Cut the entangled thread and remove it from the race.	—
Fabric puckers	There is a mistake in the upper or bobbin threading.	Check the steps for threading the machine and rethread it correctly.	43, 46
	Using improper needle or thread for the selected fabric.	Check the "Fabric/Thread/Needle Combination" chart.	58
	Thread tension is set incorrectly.	Adjust the thread tension.	67, 227
	Stitches are too long when sewing thin fabrics.	Shorten the stitch length.	67
	Needle is turned, bent or the point is dull.	Replace the needle.	56
	Spool cap is set incorrectly.	Check the method for attaching the spool cap, then reattach the spool cap.	46
	Wrong presser foot.	Use the correct presser foot.	"STITCH SETTING CHART"
High-pitched sound while sewing	Dust or lint is caught in the feed dogs.	Remove the dust or lint.	326
	Pieces of thread are caught in the race.	Clean the race.	326
	Upper threading is incorrect.	Check the steps for threading the machine and rethread the machine.	46
	There are scratches on the race.	Replace the race, or consult your authorized dealer.	326
	A bobbin designed specifically for this machine is not used.	Incorrect bobbins will not work properly. Only use a bobbin designed specifically for this machine.	43
Character pattern does not turn out	Wrong presser foot was used.	Attach the correct presser foot.	"STITCH SETTING CHART"
	Pattern adjustment settings were set incorrectly.	Revise the pattern adjustment settings.	153
	Did not use a stabilizer material on thin fabrics or stretch fabrics.	Attach a stabilizer material.	152
	Thread tension is set incorrectly.	Adjust the thread tension.	67, 227
	Fabric was pulled, pushed or fed at an angle while it was being sewn.	Sew while guiding the fabric with your hands so that the fabric is fed in a straight line.	60

Problem	Cause	Solution	Page
Embroidery pattern does not sew out correctly	Thread is twisted.	Use scissors, etc., to cut the twisted thread and remove it from the race, etc.	—
	Fabric was not inserted into the frame correctly (fabric was loose, etc.).	If the fabric is not stretched tight in the frame, the pattern may turn out poorly or there may be shrinkage of the pattern. Set the fabric into the frame correctly.	201
	Stabilizing material was not attached.	Always use stabilizing material, especially with stretch fabrics, lightweight fabrics, fabrics with a coarse weave, or fabrics that often cause pattern shrinkage. See your authorized dealer for the proper stabilizer.	198
	There was an object placed near the machine, and the carriage or embroidery frame hit the object during sewing.	If the frame bumps something during sewing, the pattern will turn out poorly. Do not place anything in the area where the frame may bump it during sewing.	212
	Fabric outside the frame edges interferes with the sewing arm, so the embroidery unit cannot move.	Reinsert the fabric in the embroidery frame so that the excess fabric is away from the sewing arm, and rotate the pattern 180 degrees.	201
	Fabric is too heavy, so the embroidery unit cannot move freely.	Place a large thick book or similar object under the arm head to lightly lift the heavy side and keep it level.	—
	Fabric is hanging off the table.	If the fabric is hanging off the table during embroidery, the embroidery unit will not move freely. Place the fabric so that it does not hang off the table or hold the fabric to keep it from dragging.	212
	Fabric is snagged or caught on something.	Stop the machine and place the fabric so that it does not get caught or snagged.	—
	Embroidery frame was removed during sewing (for example, to reset the bobbin). The presser foot was bumped or moved while removing or attaching the embroidery frame, or the embroidery unit was moved.	If the presser foot is bumped or the embroidery unit is moved during sewing, the pattern will not turn out. Be careful when removing or reattaching the embroidery frame during sewing.	223
	Stabilizer is incorrectly attached, for example, it is smaller than the embroidery frame.	Attach the stabilizer correctly.	198
Machine does not operate	There is no pattern selected.	Select a pattern.	79, 146, 186, 263
	“Start/Stop” button was not pushed.	Press the “Start/Stop” button.	3
	Main power switch is not turned on.	Turn the main power to ON.	12
	Presser foot is not lowered.	Lower the presser foot.	3
	“Start/Stop” button was pushed with the foot controller attached.	Remove the foot controller, or use the foot controller to operate the machine.	61
	The “Start/Stop” button was pressed while the machine is set for the sewing speed controller to control the zigzag stitch width.	Use the foot controller instead of the “Start/Stop” button to operate the machine, or set the Width control to OFF in the Sewing settings.	22, 61
	All keys and buttons have been locked by  .	Press  to unlock all keys and buttons.	54, 56
Embroidery unit does not operate	There is no pattern selected.	Select a pattern.	186, 263
	Main power switch is not turned on.	Turn the main power to ON.	12
	Embroidery unit is not attached correctly.	Reattach the embroidery unit correctly.	184
	Embroidery frame was attached before the unit was initialized.	Perform the initialization process correctly.	184
Nothing happens, even if the LCD display is pressed	The screen has been locked.	Press either of the following keys to unlock the screen.  	—
The fabric feeds in the opposite direction.	The feed mechanism is damaged.	Contact your dealer or the nearest authorized service center.	—
The LCD screen is fogged up.	Condensation has formed on the LCD screen.	After a while, the cloudiness will disappear.	—
Loops appear on the surface of the fabric when embroidering	The thread tension is incorrectly set.	Adjust the thread tension.	227 - 229
	The tension of the upper thread is incorrectly set for the combination of the fabric, thread and pattern being used.	Use the embroidery needle plate cover.	213
	The combination of the bobbin case and bobbin thread is incorrect.	Change the bobbin case or bobbin thread so that the correct combination is used.	212

 **CAUTION**

- This machine is equipped with a thread detection device. If the “Start/Stop” button is pushed before the upper threading is done, the machine will not operate properly. Also, depending on the pattern selected, the machine may feed the fabric even if the needle is raised. This is due to the needle bar release mechanism. At these times, the machine will make a sound different from that made during normal sewing. This is not the sign of a malfunction.
- If the power is disconnected during sewing:
Turn the main power to OFF and unplug the machine.
If you restart the machine, follow the instructions for operating the machine correctly.

ERROR MESSAGES

If the machine is not properly set and the “Start/Stop” button or the “Reverse/Reinforcement Stitch” button is pressed, or if the operation procedure is incorrect, the machine does not start. An alarm sounds and an error message is displayed on the LCD. If an error message displays, follow the instructions in the message.

Below is an explanation of error messages. Refer to these when necessary (if you press  or do the operation correctly while the error message is displayed, the message disappears).

CAUTION

- **Be sure to rethread the machine. If you press the “Start/Stop” button without rethreading the machine, the thread tension may be wrong or the needle may break and cause injury.**



This message is displayed when the motor locks due to tangled thread or for other reasons related to thread delivery.



This message is displayed when the needle plate cover is not attached.



This message is displayed when the embroidery unit is initializing.

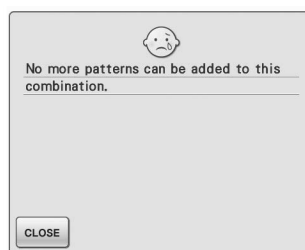

This message is displayed when you try to combine more than 71 patterns.

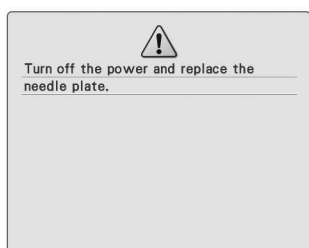

This message is displayed when you try to sew with a stitch other than a middle needle position stitch while the single-hole needle plate is installed. This message is displayed when the needle plate is removed with the machine on or when the machine is turned on and embroidery or embroidery edit mode is selected (see page 43).

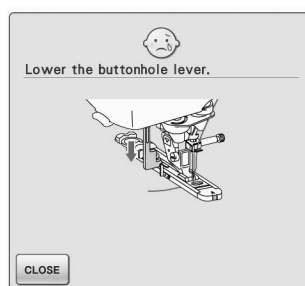

This message is displayed when the buttonhole lever is up, a buttonhole stitch is selected, and the “Start/Stop” button or “Reverse/Reinforcement Stitch” button is pushed.

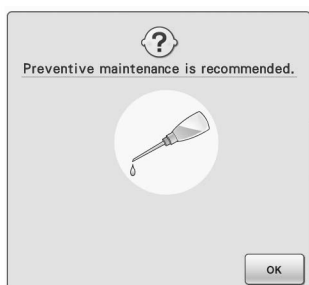

This message is displayed when the machine needs to be maintained. (see page 328)

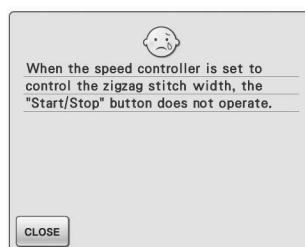

This message is displayed when the speed controller lever is set to control the zigzag stitch width, and the “Start/Stop” button is pushed. Use the foot controller to operate the machine.

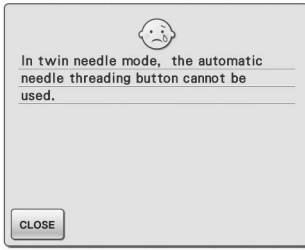

This message is displayed when the automatic needle threading button is pushed while twin needle sewing is set.



This message appears when **DELETE** or **ALL DELETE** is pressed to delete the settings for a utility stitch. To delete the selected settings, press **OK**.



This message is displayed when the “Start/Stop” button is pressed before the edge of the fabric is detected. To detect the edge of the fabric using the built-in camera, press **CLOSE**, raise the presser foot, and then perform the operation again. (see page 138)



This message is displayed when an unusable embroidery card is inserted.



This message is displayed when the built-in camera cannot detect the edge of the fabric. If this message appeared after sewing has reached 1 to 2 cm (about 3/8 to 3/4 inch) from the edge of the fabric, refer to step 13 in “Edge Sewing” on page 144. If this message appeared during edge sewing, the edge of the fabric cannot be detected by the built-in camera. Press **CLOSE**, raise the presser foot, raise the needle if it is lowered, and then perform the procedure described in “Edge Sewing” on page 140 starting from step 6. If this error message appears again, sew without using edge sewing function.



This message is displayed when the “Reverse/Reinforcement Stitch” button is pushed while the embroidery unit is attached.



This message is displayed when the foot controller is pressed while the embroidery unit is attached and machine is set up for embroidering.

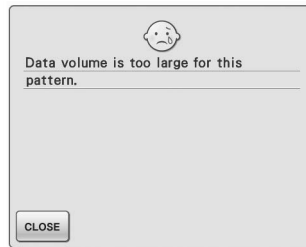

This message is displayed when the patterns you are editing take up too much memory, or if you are editing too many patterns for the memory.

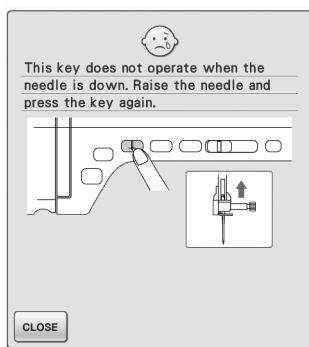

This message is displayed when a key on the LCD display is touched while the needle is in the down position.

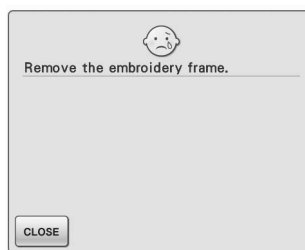

This message is displayed when the machine is in embroidery mode and the embroidery unit tries to initialize while the embroidery frame is attached.

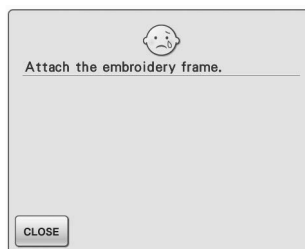

This message is displayed when the machine is ready to sew an embroidery pattern, and the "Start/Stop" button is pushed while the embroidery frame is not attached.

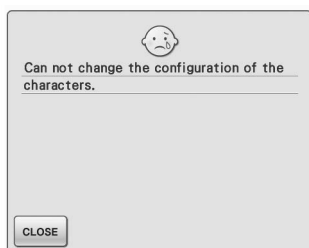

This message is displayed when there are too many characters and the curved character configuration is impossible.

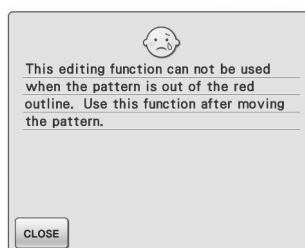

This message is displayed when the machine is in embroidery edit mode, and you try to use an editing function when the pattern is not completely within the red outline.

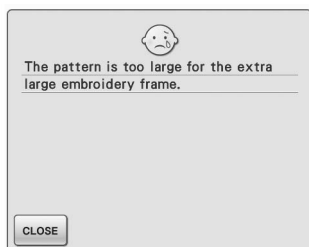

This message is displayed when the machine is in embroidery mode, and the character pattern combination is too large to fit in the embroidery frame.

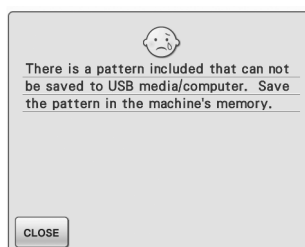

This message is displayed when you try to save a copyright protected pattern to USB media/Computer. According to copyright laws, patterns that are illegal to reproduce or edit cannot be saved to USB media or computer. If this message displays, save the pattern in the machine's memory.

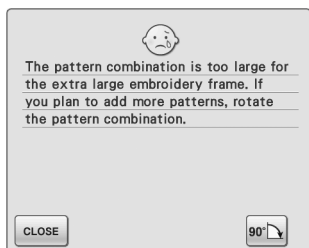

This message is displayed when the machine is in embroidery mode and the combined character pattern is too large for the embroidery frame. You can rotate the pattern 90 degrees and continue combining characters.

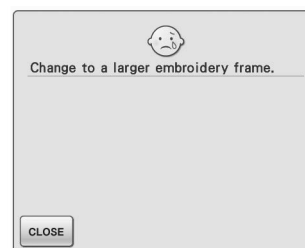

This message is displayed when the machine is in embroidery mode and the small frame is attached, and the selected pattern does not fit in the small frame. This message appears when embroidery frame (small) is attached while aligning the embroidery position using the built-in camera.



This message is displayed when **RESET** is pressed when changing thread colors.

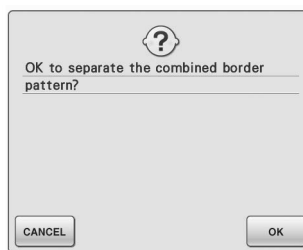

This message is displayed when rotating a saved combined pattern in the Embroidery screen.

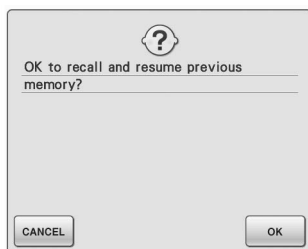

This message appears if the machine is turned off while sewing, then turned on again.

Press **OK** to return the machine to the condition (pattern position and number of stitches) when it was turned off. Follow the procedure described in "If the Thread Breaks During Sewing" on page 224 to align the needle position and sew the remainder of the pattern.

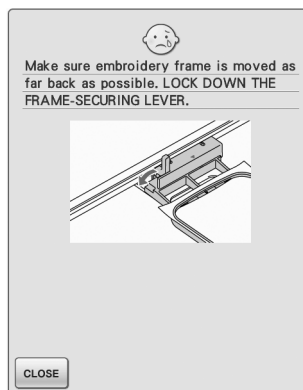

This message is displayed when the embroidery frame is attached.

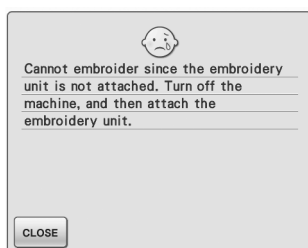

This message is displayed when the "Start/Stop" button is pushed and the machine is in embroidery mode, but the embroidery unit is not attached.

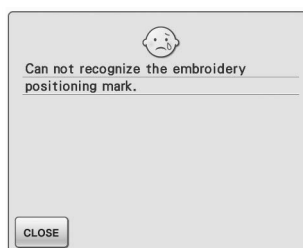

This message is displayed when the machine failed to recognize the embroidery positioning mark.

- Confirm that the embroidery positioning mark is in the selected area. If problem persists, see pages 209 and 304 to reposition mark.
- Machine failed to recognize printed positioning mark. Set "Page Scaling" to "None (100%)" and try printing the embroidery positioning mark again. (see pages 221 and 310)

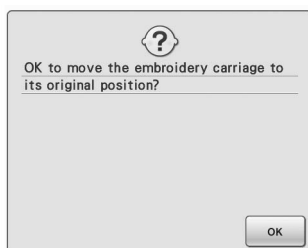

This message is displayed when replacing the embroidering bobbin thread.

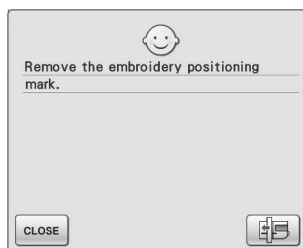

This message is displayed when the machine has recognized the embroidery position mark. Remove the embroidery positioning sticker and press **CLOSE** to continue. To remove the embroidery positioning sticker more easily, press



(see pages 209 and 304)

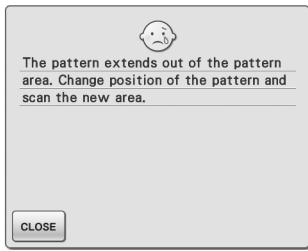

This message appears when the built-in camera is being used to align the embroidery position, but the embroidery positioning sticker is too near an edge or the pattern extends from the embroidery frame. Change the positioning of the embroidery position sticker, and then try aligning the position again. See page 206 or 302.

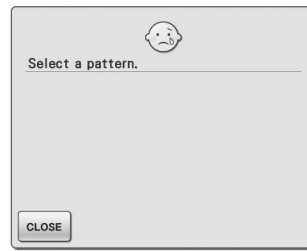

This message is displayed when there is no stitch or embroidery pattern selected and the "Start/Stop" button or the "Reverse/Reinforcement Stitch" button is pressed.



This message is displayed when the upper thread is broken or not threaded correctly, and the "Start/Stop" button or the "Reverse/Reinforcement Stitch" button is pressed.

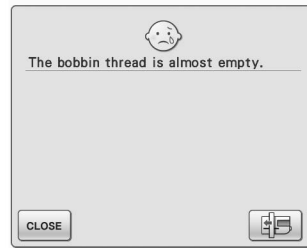

This message is displayed when the bobbin thread is running out.

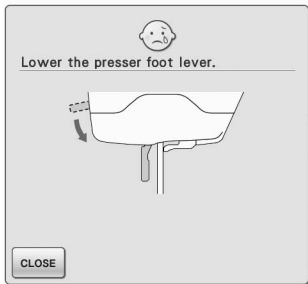

This message is displayed when the "Presser Foot Lifter" button is pushed while the presser foot lever is raised/ the needle is lowered.



This message is displayed when the memory is full and the stitch or pattern cannot be saved.



This message is displayed when the "Start/Stop" button is pushed to sew Utility stitches or Character/Decorative stitches while the foot controller is connected. (This message does not appear when embroidering).

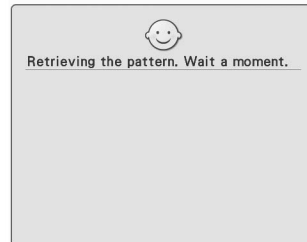

This message is displayed when the machine is retrieving a previously saved pattern while in embroidery edit mode.

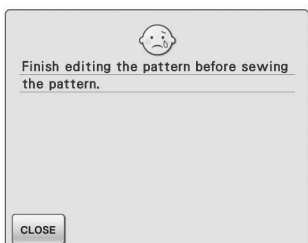

This message is displayed when the "Start/ Stop" button is pushed while the machine is in embroidery edit mode and a pattern is being edited.



This message is displayed when, after selecting a pattern, **Utility Stitch**, **Character Decorative Stitch**, or **Home** is pressed and the pattern is about to be deleted.



This message is displayed when the bobbin is being wound, and the motor locks because the thread is tangled, etc.

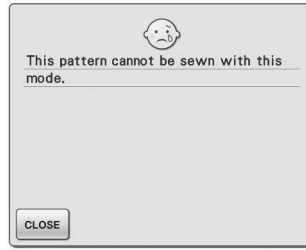

This message is displayed when the selected stitch is not available for the specific function.

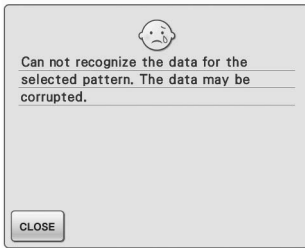

This message is displayed when there is a possibility that the data for the selected pattern is corrupted.



This message is displayed when you try to recall or save a pattern while no USB media is loaded.

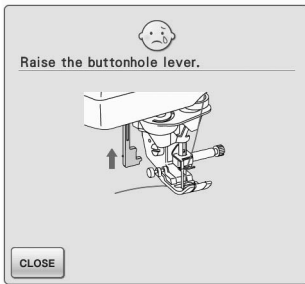

This message is displayed when the buttonhole lever is down, a stitch other than a buttonhole is selected, and the "Start/ Stop" button or the "Reverse/Reinforcement Stitch" button is pushed.



This message is displayed when you try to use incompatible media.

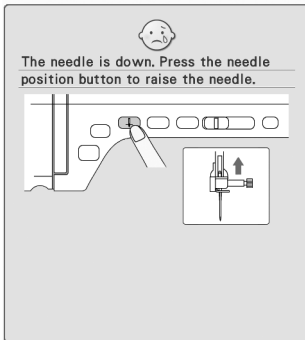

This message is displayed when the embroidery unit is attached and the power is turned on with the needle in the down position.



This message is displayed when you attempt to select a pattern after the USB media in which the pattern is saved has been changed.



This message is displayed when an error occurs with the USB media.



This message is displayed while the USB media is transmitting.

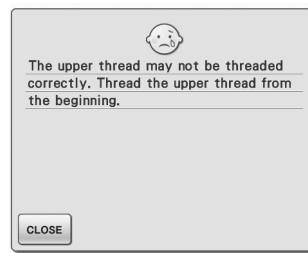

This message is displayed when it seems that the upper thread has not been threaded correctly.



This message is displayed when the memory is full and a pattern must be deleted.

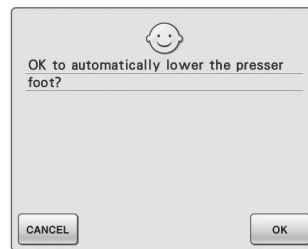

This message is displayed when the [button icon] is pressed (the presser foot is raised).

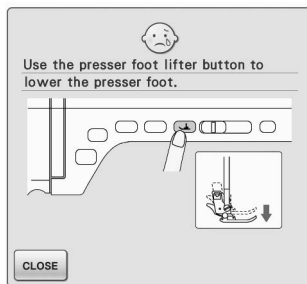

This message is displayed when a button, such as the "Start/Stop" button, is pushed while the presser foot is raised.



This message is displayed when the file size exceeds the data capacity of the machine. Confirm the file size and format. (see page 25.)



This message is displayed if some malfunction occurs.

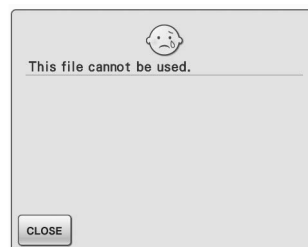

This message appears if the file format is incompatible with this machine. Check the list of compatible file formats. (see page 25.)



This message is displayed when you try to use incompatible USB media. For a list of compatible USB media, visit "<http://solutions.brother.com>".



This message is displayed when the image is deleted.

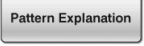

This message is displayed when you press  in the screen other than the Utility Stitch, or press  in the screen other than the Utility Stitch or Character/Decorative Stitch.

■ Alarm Sounds

If the operation was performed incorrectly, an alarm sounds to indicate that an error occurred. If the operation was performed correctly, the machine beeps to confirm the operation.

Memo

- To cancel the operation beep or to change the volume, press , display screen 3/7, and then change the setting for "Speaker". See page 23 for more details.

SPECIFICATIONS

	Item	Specification
Sewing Machine (Box 1 of 3)	Dimensions of machine	Approx. 61.5 cm (W) × 33.2 cm (H) × 27.0 cm (D) (approx. 24-7/32 inches (W) × 13-5/64 inches (H) × 10-5/8 inches (D))
	Dimensions of box	Approx. 68.5 cm (W) × 47.0 cm (H) × 39.0 cm (D) (approx. 26-31/32 inches (W) × 18-1/2 inches (H) × 15-11/32 inches (D))
	Weight of machine	Approx. 15 kg (approx. 33 lb)
	Weight of box (for shipping)	Approx. 19 kg (approx. 42 lb)
	Sewing speed	70 to 1000 stitches per minute
	Needles	Home sewing machine needles (HA × 130)
Accessory Box (Box 2 of 3)	Dimensions of box	Approx. 68.5 cm (W) × 15.2 cm (H) × 39.4 cm (D) (approx. 26-31/32 inches (W) × 6 inches (H) × 15-33/64 inches (D))
	Weight of the box (for shipping)	Approx. 5 kg (approx. 11 lb)
Embroidery Unit (Box 3 of 3)	Dimensions of embroidery unit	Approx. 51.0 cm (W) × 13.9 cm (H) × 46.2 cm (D) (approx. 20-5/64 inches (W) × 5-15/32 inch (H) × 18-3/16 inches (D))
	Dimensions of machine with embroidery unit attached	Approx. 81.6 cm (W) × 33.2 cm (H) × 46.2 cm (D) (approx. 32-1/8 inches (W) × 13-5/64 inches (H) × 18-3/16 inches (D))
	Dimensions of box	Approx. 68.5 cm (W) × 62.2 cm (H) × 23.6 cm (D) (approx. 26-31/32 inches (W) × 24-31/64 inches (H) × 9-19/64 inches (D))
	Weight of embroidery unit	Approx. 4 kg (approx. 9 lb)
	Weight of box (for shipping)	Approx. 13 kg (approx. 29 lb)
Total Shipping Weight (Combination of all 3 boxes complete)		Approx. 41 kg (approx. 90 lb)

* Please be aware that some specifications may change without notice.

UPGRADING YOUR MACHINE'S SOFTWARE

You can use USB media or a computer to download software upgrades for your sewing machine. When an upgrade program is available on "http://solutions.brother.com", please download the files following the instructions on the website and steps below.



Note

- When using USB media to upgrade the software, check that no data other than the upgrade file is saved on the USB media being used before starting to upgrade.

Upgrade Procedure Using USB Media

- 1 While pressing the "Automatic Threading" button, turn the main power to ON.

→ The following screen will appear on the LCD.

- 2 Press .

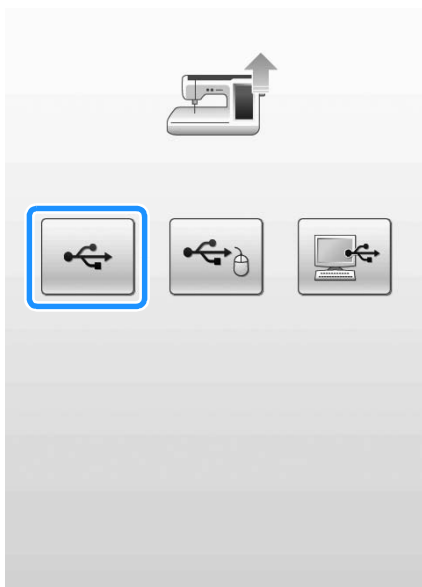

- 3 Insert the USB media into the primary (top) USB port on the machine. The media device should only contain the upgrade file.

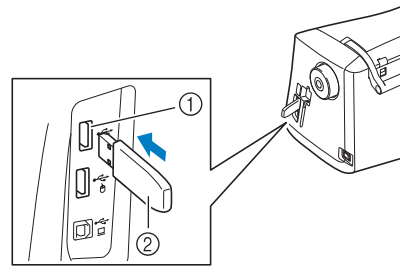

- ① Primary (top) USB port for media
- ② USB media



Note

- The access lamp will begin blinking after inserting USB media, and it will take about 5 to 6 seconds to recognize the media. (Time will differ depending on the USB media).

4 Press .



→ The upgrade file is downloaded.



Note

- If an error occurs, a red text error message will appear. When the download is performed successfully, following message will appear.



5 Remove the USB media, and turn the machine off and on again.

Upgrade Procedure Using Computer

1 While pressing the "Automatic Threading" button, turn the main power to ON.

→ The following screen will appear on the LCD.

2 Press .

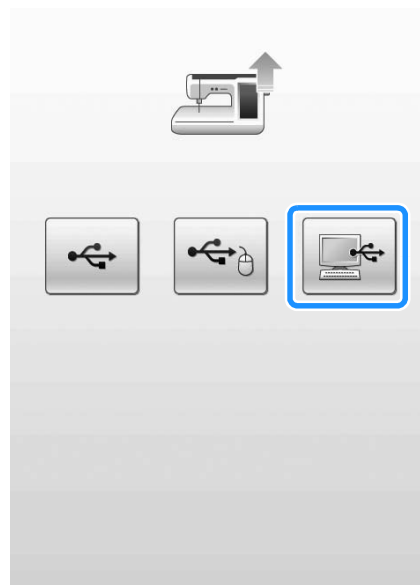

3 Plug the USB cable connector into the corresponding USB ports for the computer and for the machine.

→ "Removable Disk" will appear in "Computer (My computer)".

4 Copy the upgrade file to "Removable Disk".

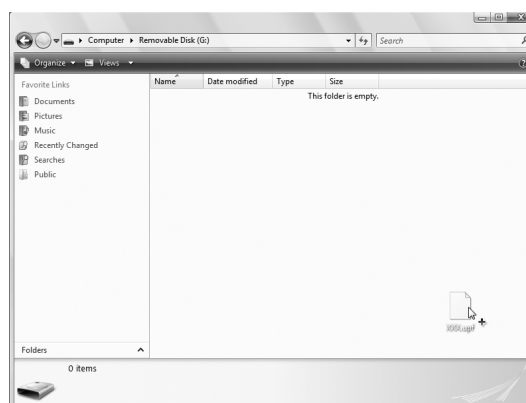

→ The following message will appear.



5 When the message disappears, press



→ The upgrade file is downloaded.



Note

- If an error occurs, a red text error message will appear. If the download is performed successfully, following message will appear.



6 Unplug the USB cable, and turn the machine off and on again.









































STITCH SETTING CHART

















































The following chart shows information for each utility stitch concerning applications, stitch lengths, stitch widths, and whether or not the twin needle mode can be used.

















































































































Note





















































- Quilting foot “C” is used when the straight stitch needle plate is attached to the machine. Refer to “Using Free motion Quilting Foot “C”” on page 105.











































Stitch	Stitch name	Presser foot		Applications	Stitch width [mm (inch)]		Stitch length [mm (inch)]		Twin needle
					Auto.	Manual	Auto.	Manual	
	Straight stitch (Left)			General sewing, gather, pintuck, etc. Reverse stitch is sewn while pressing “Reverse/Reinforcement Stitch” button.	0.0 (0)	0.0 - 7.0 (0 - 1/4)	2.5 (3/32)	0.2 - 5.0 (1/64 - 3/16)	OK (J)
	Straight stitch (Left)			General sewing, gather, pintuck, etc. Reinforcement stitch is sewn while pressing “Reverse/Reinforcement Stitch” button.	0.0 (0)	0.0 - 7.0 (0 - 1/4)	2.5 (3/32)	0.2 - 5.0 (1/64 - 3/16)	OK (J)
	Straight stitch (Middle)			General sewing, gather, pintuck, etc. Reverse stitch is sewn while pressing “Reverse/Reinforcement Stitch” button.	3.5 (1/8)	0.0 - 7.0 (0 - 1/4)	2.5 (3/32)	0.2 - 5.0 (1/64 - 3/16)	OK (J)
	Straight stitch (Middle)			General sewing, gather, pintuck, etc. Reinforcement stitch is sewn while pressing “Reverse/Reinforcement Stitch” button.	3.5 (1/8)	0.0 - 7.0 (0 - 1/4)	2.5 (3/32)	0.2 - 5.0 (1/64 - 3/16)	OK (J)
	Triple stretch stitch			General sewing for reinforcement and decorative topstitching	0.0 (0)	0.0 - 7.0 (0 - 1/4)	2.5 (3/32)	1.5 - 4.0 (1/16 - 3/16)	OK (J)
	Stem stitch			Reinforced stitching, sewing and decorative applications	1.0 (1/16)	1.0 - 3.0 (1/16 - 1/8)	2.5 (3/32)	1.0 - 4.0 (1/16 - 3/16)	OK (J)
	Decorative stitch			Decorative stitching, top stitching	0.0 (0)	0.0 - 7.0 (0 - 1/4)	2.5 (3/32)	1.0 - 4.0 (1/16 - 3/16)	OK (J)
	Basting stitch			Basting	0.0 (0)	0.0 - 7.0 (0 - 1/4)	20 (3/4)	5 - 30 (3/16 - 1-3/16)	NO
	Zigzag stitch			For overcasting, mending. Reverse stitch is sewn while pressing “Reverse/Reinforcement Stitch” button.	3.5 (1/8)	0.0 - 7.0 (0 - 1/4)	1.4 (1/16)	0.0 - 4.0 (0 - 3/16)	OK (J)
	Zigzag stitch			For overcasting, mending. Reinforcement stitch is sewn while pressing “Reverse/Reinforcement Stitch” button.	3.5 (1/8)	0.0 - 7.0 (0 - 1/4)	1.4 (1/16)	0.0 - 4.0 (0 - 3/16)	OK (J)
	Zigzag stitch (right)			Start from right needle position, zigzag sew at left.	3.5 (1/8)	2.5 - 5.0 (3/32 - 3/16)	1.4 (1/16)	0.3 - 4.0 (1/64 - 3/16)	OK (J)
	Zigzag stitch (left)			Start from left needle position, zigzag sew at right.	3.5 (1/8)	2.5 - 5.0 (3/32 - 3/16)	1.4 (1/16)	0.3 - 4.0 (1/64 - 3/16)	OK (J)
	2 steps elastic zigzag			Overcasting (medium weight and stretch fabrics), tape and elastic	5.0 (3/16)	1.5 - 7.0 (1/16 - 1/4)	1.0 (1/16)	0.2 - 4.0 (1/64 - 1/16)	OK (J)























































Stitch	Stitch name	Presser foot		Applications	Stitch width [mm (inch)]		Stitch length [mm (inch)]		Twin needle
					Auto.	Manual	Auto.	Manual	
	2 steps elastic zigzag			Overcasting (medium weight and stretch fabrics), tape and elastic	5.0 (3/16)	1.5 - 7.0 (1/16 - 1/4)	1.0 (1/16)	0.2 - 4.0 (1/64 - 1/16)	OK (J)
	3 steps elastic zigzag			Overcasting (medium, heavyweight and stretch fabrics), tape and elastic	5.0 (3/16)	1.5 - 7.0 (1/16 - 1/4)	1.0 (1/16)	0.2 - 4.0 (1/64 - 1/16)	OK (J)
	Overcasting stitch			Reinforcing of light and medium weight fabrics	3.5 (1/8)	2.5 - 5.0 (3/32 - 3/16)	2.0 (1/16)	1.0 - 4.0 (1/16 - 3/16)	NO
	Overcasting stitch			Reinforcing of heavyweight fabric	5.0 (3/16)	2.5 - 5.0 (3/32 - 3/16)	2.5 (3/32)	1.0 - 4.0 (1/16 - 3/16)	NO
	Overcasting stitch			Reinforcing of medium, heavyweight and easily friable fabrics or decorative stitching.	5.0 (3/16)	3.5 - 5.0 (1/8 - 3/16)	2.5 (3/32)	1.0 - 4.0 (1/16 - 3/16)	NO
	Overcasting stitch			Reinforced seaming of stretch fabric	5.0 (3/16)	0.0 - 7.0 (0 - 9/32)	2.5 (3/32)	0.5 - 4.0 (1/32 - 3/16)	OK (J)
	Overcasting stitch			Reinforcing of medium stretch fabric and heavyweight fabric, decorative stitching	5.0 (3/16)	0.0 - 7.0 (0 - 9/32)	2.5 (3/32)	0.5 - 4.0 (1/32 - 3/16)	OK (J)
	Overcasting stitch			Reinforcement of stretch fabric or decorative stitching	4.0 (3/16)	0.0 - 7.0 (0 - 1/4)	4.0 (3/16)	1.0 - 4.0 (1/16 - 3/16)	OK (J)
	Overcasting stitch			Stretch knit seam	5.0 (3/16)	0.0 - 7.0 (0 - 1/4)	4.0 (3/16)	1.0 - 4.0 (1/16 - 3/16)	NO
	Single diamond overcast			Reinforcement and seaming stretch fabric	6.0 (15/64)	1.0 - 7.0 (1/16 - 1/4)	3.0 (1/8)	1.0 - 4.0 (1/16 - 3/16)	OK (J)
	Single diamond overcast			Reinforcement of stretch fabric	6.0 (15/64)	1.0 - 7.0 (1/16 - 1/4)	1.8 (1/16)	1.0 - 4.0 (1/16 - 3/16)	OK (J)
	With side cutter			Straight stitch while cutting fabrics	0.0 (0)	0.0 - 2.5 (0 - 3/32)	2.5 (3/32)	0.2 - 5.0 (1/64 - 3/16)	NO
	With side cutter			Zigzag stitch while cutting fabrics	3.5 (1/8)	3.5 - 5.0 (1/8 - 3/16)	1.4 (1/16)	0.0 - 4.0 (0 - 3/16)	NO
	With side cutter			Overcasting stitch while cutting fabrics	3.5 (1/8)	3.5 - 5.0 (1/8 - 3/16)	2.0 (1/16)	1.0 - 4.0 (1/16 - 3/16)	NO
	With side cutter			Overcasting stitch while cutting fabrics	5.0 (3/16)	3.5 - 5.0 (1/8 - 3/16)	2.5 (3/32)	1.0 - 4.0 (1/16 - 3/16)	NO
	With side cutter			Overcasting stitch while cutting fabrics	5.0 (3/16)	3.5 - 5.0 (1/8 - 3/16)	2.5 (3/32)	1.0 - 4.0 (1/16 - 3/16)	NO
	Piecing stitch (Right)			Piecing/patchwork 6.5 mm (approx. 1/4 inch) left seam allowance	5.5 (7/32)	0.0 - 7.0 (0 - 1/4)	2.0 (1/16)	0.2 - 5.0 (1/64 - 3/16)	NO
	Piecing stitch (Middle)			Piecing/patchwork	—	—	2.0 (1/16)	0.2 - 5.0 (1/64 - 3/16)	NO

























































Stitch	Stitch name	Presser foot		Applications	Stitch width [mm (inch)]		Stitch length [mm (inch)]		Twin needle
					Auto.	Manual	Auto.	Manual	
	Piecing stitch (Left)			Piecework/patchwork 6.5 mm (approx. 1/4 inch) left seam allowance	1.5 (1/16)	0.0 - 7.0 (0 - 1/4)	2.0 (1/16)	0.2 - 5.0 (1/64 - 3/16)	NO
	Hand-look quilting			Quilting stitch made to look like hand quilting stitch	0.0 (0)	0.0 - 7.0 (0 - 1/4)	2.5 (3/32)	1.0 - 4.0 (1/16 - 3/16)	NO
	Quilting appliqué zigzag stitch			Zigzag stitch for quilting and sewing on appliqué quilt pieces	3.5 (1/8)	0.0 - 7.0 (0 - 1/4)	1.4 (1/16)	0.0 - 4.0 (0 - 3/16)	NO
	Quilting appliqué stitch			Quilting stitch for invisible appliqué or attaching binding	1.5 (1/16)	0.5 - 5.0 (1/64 - 3/16)	1.8 (1/16)	1.0 - 4.0 (1/16 - 3/16)	NO
	Quilting stippling			Background quilting	7.0 (1/4)	1.0 - 7.0 (1/16 - 1/4)	1.6 (1/16)	1.0 - 4.0 (1/16 - 3/16)	NO
	Blind hem stitch			Hemming woven fabrics	0.0 (0)	+3.0 - -3.0 (+1/8 - -1/8)	2.0 (1/16)	1.0 - 3.5 (1/16 - 1/8)	NO
	Blind hem stitch stretch			Hemming stretch fabric	0.0 (0)	+3.0 - -3.0 (+1/8 - -1/8)	2.0 (1/16)	1.0 - 3.5 (1/16 - 1/8)	NO
	Blanket stitch			Appliqués, decorative blanket stitch	3.5 (1/8)	2.5 - 7.0 (3/32 - 1/4)	2.5 (3/32)	1.6 - 4.0 (1/16 - 3/16)	OK (J)
	Shell tuck edge			Shell tuck edge finish on fabrics	4.0 (3/16)	0.0 - 7.0 (0 - 1/4)	2.5 (3/32)	0.2 - 4.0 (1/64 - 1/16)	OK (J)
	Satin scallop stitch			Decorating collar of blouse, edge of handkerchief	5.0 (3/16)	2.5 - 7.0 (3/32 - 1/4)	0.5 (1/32)	0.1 - 1.0 (1/64 - 1/16)	OK (J)
	Scallop stitch			Decorating collar of blouse, edge of handkerchief	7.0 (1/4)	0.0 - 7.0 (0 - 1/4)	1.4 (1/16)	1.0 - 4.0 (1/16 - 3/16)	NO
	Patchwork join stitch			Patchwork stitches, decorative stitching	4.0 (1/16)	0.0 - 7.0 (0 - 1/4)	1.2 (1/16)	0.2 - 4.0 (1/64 - 1/16)	OK (J)
	Patchwork double overlock stitch			Patchwork stitches, decorative stitching	5.0 (3/16)	2.5 - 7.0 (3/32 - 1/4)	2.5 (3/32)	1.0 - 4.0 (1/16 - 3/16)	OK (J)
	Couching stitch			Decorative stitching, attaching cord and couching	5.0 (3/16)	0.0 - 7.0 (0 - 1/4)	1.2 (1/16)	0.2 - 4.0 (1/64 - 1/16)	OK (J)
	Smocking stitch			Smocking, decorative stitching	5.0 (3/16)	0.0 - 7.0 (0 - 1/4)	1.6 (1/16)	1.0 - 4.0 (1/16 - 3/16)	OK (J)
	Feather stitch			Fagoting, decorative stitching	5.0 (3/16)	0.0 - 7.0 (0 - 1/4)	2.5 (3/32)	1.0 - 4.0 (1/16 - 3/16)	OK (J)
	Fagoting cross stitch			Fagoting, bridging and decorative stitching	5.0 (3/16)	2.5 - 7.0 (3/32 - 1/4)	2.5 (3/32)	1.0 - 4.0 (1/16 - 3/16)	OK (J)
	Tape attaching			Attaching tape to seam in stretch fabric	4.0 (3/16)	0.0 - 7.0 (0 - 1/4)	1.0 (1/16)	0.2 - 4.0 (1/64 - 3/16)	OK (J)





























Stitch	Stitch name	Presser foot		Applications	Stitch width [mm (inch)]		Stitch length [mm (inch)]		Twin needle
					Auto.	Manual	Auto.	Manual	
	Ladder stitch			Decorative stitching	4.0 (3/16)	0.0 - 7.0 (0 - 1/4)	3.0 (1/8)	2.0 - 4.0 (1/16 - 3/16)	NO
	Rick-rack stitch			Decorative top stitching	4.0 (3/16)	0.0 - 7.0 (0 - 1/4)	2.5 (3/32)	1.0 - 4.0 (1/16 - 3/16)	OK (J)
	Decorative stitch			Decorative stitching	1.0 (1/16)	1.0 - 3.0 (1/16 - 1/8)	2.5 (3/32)	1.0 - 4.0 (1/16 - 3/16)	OK (J)
	Decorative stitch			Decorative stitching	5.5 (3/16)	0.0 - 7.0 (0 - 1/4)	1.6 (1/16)	1.0 - 4.0 (1/16 - 3/16)	OK (J)
	Serpentine stitch			Decorative stitching and attaching elastic	5.0 (3/16)	1.5 - 7.0 (1/16 - 1/4)	1.0 (1/16)	0.2 - 4.0 (1/64 - 3/16)	OK (J)
	Decorative stitch			Decorative stitching and appliqué	6.0 (15/64)	1.0 - 7.0 (1/16 - 1/4)	1.0 (1/16)	0.2 - 4.0 (1/64 - 3/16)	OK (J)
	Decorative stippling stitch			Decorative stitching	7.0 (1/4)	1.0 - 7.0 (1/16 - 1/4)	1.6 (1/16)	1.0 - 4.0 (1/16 - 3/16)	NO
	Hemstitching			Decorative hems, triple straight at left	1.0 (1/16)	1.0 - 7.0 (1/16 - 1/4)	2.5 (3/32)	1.5 - 4.0 (1/16 - 3/16)	OK (J)
	Hemstitching			Decorative hems, triple straight at center	3.5 (1/8)	1.0 - 7.0 (1/16 - 1/4)	2.5 (3/32)	1.5 - 4.0 (1/16 - 3/16)	OK (J)
	Hemstitching zigzag			Decorative hems, top stitching	6.0 (15/64)	1.5 - 7.0 (1/16 - 1/4)	3.0 (1/8)	1.0 - 4.0 (1/16 - 3/16)	OK (J)
	Hemstitching			Decorative hems, lace attaching pin stitch	3.5 (1/8)	1.5 - 7.0 (1/16 - 1/4)	2.5 (3/32)	1.6 - 4.0 (1/16 - 3/16)	NO
	Hemstitching			Decorative hems	3.0 (1/8)	1.5 - 7.0 (1/16 - 1/4)	3.5 (1/8)	1.6 - 4.0 (1/16 - 3/16)	NO
	Hemstitching			Decorative hems daisy stitch	6.0 (15/64)	1.5 - 7.0 (1/16 - 1/4)	3.0 (1/8)	1.5 - 4.0 (1/16 - 3/16)	NO
	Hemstitching			Heirloom, decorative hems	5.0 (3/16)	1.5 - 7.0 (1/16 - 1/4)	3.5 (1/8)	1.6 - 4.0 (1/16 - 3/16)	NO
	Hemstitching			Heirloom, decorative hems	5.0 (3/16)	1.5 - 7.0 (1/16 - 1/4)	3.5 (1/8)	1.5 - 4.0 (1/16 - 3/16)	NO
	Hemstitching			Heirloom, decorative hems	5.0 (3/16)	1.5 - 7.0 (1/16 - 1/4)	3.5 (1/8)	1.6 - 4.0 (1/16 - 3/16)	OK (J)
	Hemstitching			Heirloom, decorative hems	5.0 (3/16)	1.5 - 7.0 (1/16 - 1/4)	4.0 (3/16)	1.5 - 4.0 (1/16 - 3/16)	OK (J)
	Hemstitching			Heirloom, decorative hems	4.0 (3/16)	1.5 - 7.0 (1/16 - 1/4)	2.5 (3/32)	1.5 - 4.0 (1/16 - 3/16)	OK (J)

Stitch	Stitch name	Presser foot		Applications	Stitch width [mm (inch)]		Stitch length [mm (inch)]		Twin needle
					Auto.	Manual	Auto.	Manual	
	Honeycomb stitch			Heirloom, decorative hems	5.0 (3/64)	1.5 - 7.0 (1/16 - 1/4)	2.5 (3/32)	1.5 - 4.0 (1/16 - 3/16)	OK (J)
	Honeycomb stitch			Heirloom, decorative hems	6.0 (15/64)	1.5 - 7.0 (1/16 - 1/4)	3.5 (1/8)	1.5 - 4.0 (1/16 - 3/16)	OK (J)
	Hemstitching			Heirloom, decorative hems	6.0 (15/64)	1.5 - 7.0 (1/16 - 1/4)	1.6 (1/16)	1.0 - 4.0 (1/16 - 3/16)	OK (J)
	Hemstitching			Heirloom, decorative hems	6.0 (15/64)	1.5 - 7.0 (1/16 - 1/4)	3.0 (1/8)	1.5 - 4.0 (1/16 - 3/16)	NO
	Hemstitching			Heirloom, decorative hems	6.0 (15/64)	1.5 - 7.0 (1/16 - 1/4)	4.0 (3/16)	1.5 - 4.0 (1/16 - 3/16)	OK (J)
	Hemstitching			Heirloom, decorative hems	4.0 (3/16)	1.5 - 7.0 (1/16 - 1/4)	2.5 (3/32)	1.6 - 4.0 (1/16 - 3/16)	NO
	Hemstitching			Heirloom, decorative hems	5.0 (3/16)	1.5 - 7.0 (1/16 - 1/4)	2.0 (1/16)	1.5 - 4.0 (1/16 - 3/16)	OK (J)
	Hemstitching			Decorative hems and bridging stitch	6.0 (15/64)	1.5 - 7.0 (1/16 - 1/4)	2.0 (1/16)	1.5 - 4.0 (1/16 - 3/16)	OK (J)
	Hemstitching			Decorative hems. Fagoting, attaching ribbon	5.0 (3/16)	1.5 - 7.0 (1/16 - 1/4)	3.0 (1/8)	1.5 - 4.0 (1/16 - 3/16)	OK (J)
	Hemstitching			Decorative hems, smocking	6.0 (15/64)	1.5 - 7.0 (1/16 - 1/4)	1.6 (1/16)	1.0 - 4.0 (1/16 - 3/16)	NO
	Hemstitching			Decorative hems, smocking	5.0 (3/16)	1.5 - 7.0 (1/16 - 1/4)	1.6 (1/16)	1.0 - 4.0 (1/16 - 3/16)	NO
	Hemstitching			Decorative hems, smocking	5.0 (3/16)	1.5 - 7.0 (1/16 - 1/4)	1.6 (1/16)	1.0 - 4.0 (1/16 - 3/16)	NO
	Hemstitching			Decorative hems	5.0 (3/16)	1.5 - 7.0 (1/16 - 1/4)	1.6 (1/16)	1.0 - 4.0 (1/16 - 3/16)	NO
	Ladder stitch			Decorative hems. Fagoting, attaching ribbon	7.0 (1/4)	5.0 - 7.0 (3/16 - 1/4)	1.6 (1/16)	1.0 - 2.5 (1/16 - 3/32)	NO
	Narrow rounded buttonhole			Buttonhole on light to medium weight fabrics	5.0 (3/16)	3.0 - 5.0 (1/8 - 3/16)	0.4 (1/64)	0.2 - 1.0 (1/64 - 1/16)	NO
	Wide round ended buttonhole			Buttonholes with extra space for larger buttons	5.5 (7/32)	3.5 - 5.5 (1/8 - 7/32)	0.4 (1/64)	0.2 - 1.0 (1/64 - 1/16)	NO
	Tapered round ended buttonhole			Reinforced waist tapered buttonholes	5.0 (3/16)	3.0 - 5.0 (1/8 - 3/16)	0.4 (1/64)	0.2 - 1.0 (1/64 - 1/16)	NO
	Round ended buttonhole			Buttonholes with vertical bar tack in heavyweight fabrics	5.0 (3/16)	3.0 - 5.0 (1/8 - 3/16)	0.4 (1/64)	0.2 - 1.0 (1/64 - 1/16)	NO

Stitch	Stitch name	Presser foot		Applications	Stitch width [mm (inch)]		Stitch length [mm (inch)]		Twin needle
					Auto.	Manual	Auto.	Manual	
	Round ended buttonhole			Buttonholes with bar tack	5.0 (3/16)	3.0 - 5.0 (1/8 - 3/16)	0.4 (1/64)	0.2 - 1.0 (1/64 - 1/16)	NO
	Round double ended buttonhole			Buttonholes for fine, medium to heavyweight fabrics	5.0 (3/16)	3.0 - 5.0 (1/8 - 3/16)	0.4 (1/64)	0.2 - 1.0 (1/64 - 1/16)	NO
	Narrow squared buttonhole			Buttonholes for light to medium weight fabrics	5.0 (3/16)	3.0 - 5.0 (1/8 - 3/16)	0.4 (1/64)	0.2 - 1.0 (1/64 - 1/16)	NO
	Wide squared buttonhole			Buttonholes with extra space for larger decorative buttons	5.5 (7/32)	3.5 - 5.5 (1/8 - 7/32)	0.4 (1/64)	0.2 - 1.0 (1/64 - 1/16)	NO
	Squared buttonhole			Heavy-duty buttonholes with vertical bar tacks	5.0 (7/32)	3.0 - 5.0 (1/8 - 3/16)	0.4 (1/64)	0.2 - 1.0 (1/64 - 1/16)	NO
	Stretch buttonhole			Buttonholes for stretch or woven fabrics	6.0 (15/64)	3.0 - 6.0 (1/8 - 15/64)	1.0 (1/16)	0.5 - 2.0 (1/32 - 1/16)	NO
	Heirloom buttonhole			Buttonholes for heirloom and stretch fabrics	6.0 (15/64)	3.0 - 6.0 (1/8 - 15/64)	1.5 (1/16)	1.0 - 3.0 (1/1 - 1/8)	NO
	Bound buttonhole			The first step in making bound buttonholes	5.0 (3/16)	0.0 - 6.0 (0 - 15/64)	2.0 (1/16)	0.2 - 4.0 (1/64 - 3/16)	NO
	Keyhole buttonhole			Buttonholes in heavyweight or thick fabrics for larger flat buttons	7.0 (1/4)	3.0 - 7.0 (1/8 - 1/4)	0.5 (1/32)	0.3 - 1.0 (1/64 - 1/16)	NO
	Tapered keyhole buttonhole			Buttonholes in medium to heavy weight fabrics for larger flat buttons	7.0 (1/4)	3.0 - 7.0 (1/8 - 1/4)	0.5 (1/32)	0.3 - 1.0 (1/64 - 1/16)	NO
	Keyhole buttonhole			Buttonholes with vertical bar tack for reinforcement in heavyweight or thick fabrics	7.0 (1/4)	3.0 - 7.0 (1/8 - 1/4)	0.5 (1/32)	0.3 - 1.0 (1/64 - 1/16)	NO
	4 steps buttonhole 1			Left side of 4 step buttonhole	5.0 (7/32)	1.5 - 7.0 (1/16 - 1/4)	0.4 (1/64)	0.2 - 1.0 (1/64 - 1/16)	NO
	4 steps buttonhole 2			Bar tack of 4 step buttonhole	5.0 (7/32)	1.5 - 7.0 (1/16 - 1/4)	0.4 (1/64)	0.2 - 1.0 (1/64 - 1/16)	NO
	4 steps buttonhole 3			Right side of 4 step buttonhole	5.0 (7/32)	1.5 - 7.0 (1/16 - 1/4)	0.4 (1/64)	0.2 - 1.0 (1/64 - 1/16)	NO
	4 steps buttonhole 4			Bar tack of 4 step buttonhole	5.0 (7/32)	1.5 - 7.0 (1/16 - 1/4)	0.4 (1/64)	0.2 - 1.0 (1/64 - 1/16)	NO
	Darning			Darning of medium weight fabric	7.0 (1/4)	2.5 - 7.0 (3/32 - 1/4)	2.0 (1/16)	0.4 - 2.5 (1/64 - 1/16)	NO
	Darning			Darning of heavyweight fabric	7.0 (1/4)	2.5 - 7.0 (3/32 - 1/4)	2.0 (1/16)	0.4 - 2.5 (1/64 - 1/16)	NO
	Bar tack			Reinforcement at opening of pocket, etc.	2.0 (1/16)	1.0 - 3.0 (1/16 - 1/8)	0.4 (1/64)	0.3 - 1.0 (1/64 - 1/16)	NO

Stitch	Stitch name	Presser foot		Applications	Stitch width [mm (inch)]		Stitch length [mm (inch)]		Twin needle
					Auto.	Manual	Auto.	Manual	
	Button sewing			Attaching buttons	3.5 (1/8)	2.5 - 4.5 (3/32 - 3/16)	—	—	NO
	Eyelet			For making eyelets, holes on belts, etc.	7.0 (1/4)	7.0 6.0 5.0 (1/4 15/64 3/16)	7.0 (1/4)	7.0 6.0 5.0 (1/4 15/64 3/16)	NO
	Star eyelet			For making star-shaped eyelets on holes.	—	—	—	—	NO
	Diagonally left up (Straight)			For attaching appliqué on tubular pieces of fabric and mitering corners	—	—	—	—	NO
	Reverse (Straight)			For attaching appliqué on tubular pieces of fabric and mitering corners	—	—	—	—	NO
	Diagonally right up (Straight)			For attaching appliqué on tubular pieces of fabric and mitering corners	—	—	—	—	NO
	Sideways to left (Straight)			For attaching appliqué on tubular pieces of fabric	—	—	—	—	NO
	Sideways to right (Straight)			For attaching appliqué on tubular pieces of fabric	—	—	—	—	NO
	Diagonally left down (Straight)			For attaching appliqué on tubular pieces of fabric and mitering corners	—	—	—	—	NO
	Forward (Straight)			For attaching appliqué on tubular pieces of fabric and mitering corners	—	—	—	—	NO
	Diagonally right down (Straight)			For attaching appliqué on tubular pieces of fabric and mitering corners	—	—	—	—	NO
	Sideways to left (Zigzag)			For attaching appliqué on tubular pieces of fabric	—	—	—	—	NO
	Sideways to right (Zigzag)			For attaching appliqué on tubular pieces of fabric	—	—	—	—	NO
	Forward (Zigzag)			For attaching appliqué on tubular pieces of fabric and mitering corners	—	—	—	—	NO
	Reverse (Zigzag)			For attaching appliqué on tubular pieces of fabric and mitering corners	—	—	—	—	NO
	Piecing stitch (Middle)			Piecework/patchwork	—	—	2.0 (1/16)	0.2 - 5.0 (1/64 - 3/16)	NO
	Piecing stitch (Right)			Piecework/patchwork 6.5 mm (approx. 1/4 inch) right seam allowance	5.50 (7/32)	0.00 - 7.00 (0 - 1/4)	2.0 (1/16)	0.2 - 5.0 (1/64 - 3/16)	NO
	Piecing stitch (Left)			Piecework/patchwork 6.5 mm (approx. 1/4 inch) left seam allowance	1.50 (1/16)	0.00 - 7.00 (0 - 1/4)	2.0 (1/16)	0.2 - 5.0 (1/64 - 3/16)	NO

Stitch	Stitch name	Presser foot		Applications	Stitch width [mm (inch)]		Stitch length [mm (inch)]		Twin needle
					Auto.	Manual	Auto.	Manual	
	Hand-look quilting			Quilting stitch made to look like hand quilting stitch	3.50	0.00 - 7.00 (0 - 1/4)	2.5 (3/32)	1.0 - 4.0 (1/16 - 3/16)	NO
	Basting stitch			Basting	3.50	0.00 - 7.00 (0 - 1/4)	20 (3/4)	5 - 30 (3/16 - 1-3/16)	NO
	Stem stitch			Reinforced stitching, sewing and decorative applications	1.00 (1/16)	1.00 - 3.00 (1/16 - 1/8)	2.5 (3/32)	1.0 - 4.0 (1/16 - 3/16)	NO
	Quilting appliqué zigzag stitch			Zigzag stitch for quilting and sewing on appliqué quilt pieces	3.50 (1/8)	0.00 - 7.00 (0 - 1/4)	1.6	0.0 - 4.0 (0 - 3/16)	NO
	Zigzag stitch (Right)			Start from right needle position, zigzag sew at left	3.50 (1/8)	2.50 - 5.00 (3/32 - 3/16)	1.6	0.3 - 4.0 (1/64 - 3/16)	NO
	Zigzag stitch (Left)			Start from left needle position, zigzag sew at right	3.50 (1/8)	2.50 - 5.00 (3/32 - 3/16)	1.6	0.3 - 4.0 (1/64 - 3/16)	NO
	2 steps elastic zigzag			Overcasting (medium weight and stretch fabrics), tape and elastic	5.00 (3/16)	1.50 - 7.00 (1/16 - 1/4)	1.0 (1/16)	0.2 - 4.0 (1/64 - 1/16)	NO
	3 steps elastic zigzag			Overcasting (medium, heavyweight and stretch fabrics), tape and elastic	5.00 (3/16)	1.50 - 7.00 (1/16 - 1/4)	1.0 (1/16)	0.2 - 4.0 (1/64 - 1/16)	NO
	Quilting appliqué stitch			Quilting stitch for invisible appliqué or attaching binding	2.00	0.50 - 5.00 (1/64 - 3/16)	2.0	1.0 - 4.0 (1/16 - 3/16)	NO
	Shell tuck edge			Shell tuck edge finish on fabrics	4.00 (3/16)	0.00 - 7.00 (0 - 1/4)	2.5 (3/32)	0.2 - 4.0 (1/64 - 1/16)	NO
	Blanket stitch			Appliqués, decorative blanket stitch	3.50 (1/8)	2.50 - 7.00 (3/32 - 1/4)	2.5 (3/32)	1.6 - 4.0 (1/16 - 3/16)	NO
	Quilting stippling			Background quilting	7.00 (1/4)	1.00 - 7.00 (1/16 - 1/4)	1.6 (1/16)	1.0 - 4.0 (1/16 - 3/16)	NO
	Overcasting stitch			Stretch knit seam	5.00 (3/16)	0.00 - 7.00 (0 - 1/4)	4.0 (3/16)	1.0 - 4.0 (1/16 - 3/16)	NO
	Tape attaching			Attaching tape to seam in stretch fabric	5.50	0.00 - 7.00 (0 - 1/4)	1.4	0.2 - 4.0 (1/61 - 3/16)	NO
	Serpentine stitch			Decorative stitching and attaching elastic	5.00 (3/16)	1.50 - 7.00 (1/16 - 1/4)	2.0	0.2 - 4.0 (1/64 - 3/16)	NO
	Feather stitch			Fagoting, decorative stitching	5.00 (3/16)	0.00 - 7.00 (0 - 1/4)	2.5 (3/32)	1.0 - 4.0 (1/16 - 3/16)	NO
	Fagoting cross stitch			Fagoting, bridging and decorative stitching	5.00 (3/16)	2.50 - 7.00 (3/32 - 1/4)	2.5 (3/32)	1.0 - 4.0 (1/16 - 3/16)	NO
	Couching stitch			Decorative stitching, attaching cord and couching	5.00 (3/16)	0.00 - 7.00 (0 - 1/4)	1.2 (1/16)	0.2 - 4.0 (1/64 - 1/16)	NO

Stitch	Stitch name	Presser foot		Applications	Stitch width [mm (inch)]		Stitch length [mm (inch)]		Twin needle
					Auto.	Manual	Auto.	Manual	
	Patchwork double overlock stitch			Patchwork stitches, decorative stitching	5.00 (3/16)	2.50 - 7.00 (3/32 - 1/4)	2.5 (3/32)	1.0 - 4.0 (1/16 - 3/16)	NO
	Smocking stitch			Smocking, decorative stitching	5.00 (3/16)	0.00 - 7.00 (0 - 1/4)	1.6 (1/16)	1.0 - 4.0 (1/16 - 3/16)	NO
	Rick-rack stitch			Decorative top stitching	4.00 (3/16)	0.00 - 7.00 (0 - 1/4)	2.5 (3/32)	1.0 - 4.0 (1/16 - 3/16)	NO
	Decorative stitch			Decorative stitching and appliqué	6.00 (15/64)	1.00 - 7.00 (1/16 - 1/4)	1.0 (1/16)	0.2 - 4.0 (1/64 - 3/16)	NO
	Decorative stitch			Decorative stitching	5.50 (3/16)	0.00 - 7.00 (0 - 1/4)	1.6 (1/16)	1.0 - 4.0 (1/16 - 3/16)	NO
	Hemstitching			Heirloom, decorative hems	5.00 (3/16)	1.50 - 7.00 (1/16 - 1/4)	2.0 (1/16)	1.5 - 4.0 (1/16 - 3/16)	NO
	Hemstitching			Decorative hems and bridging stitch	6.00 (15/64)	1.50 - 7.00 (1/16 - 1/4)	2.0 (1/16)	1.5 - 4.0 (1/16 - 3/16)	NO
	Single diamond overcast			Reinforcement and seaming stretch fabric	6.00 (15/64)	1.00 - 7.00 (1/16 - 1/4)	3.0 (1/8)	1.0 - 4.0 (1/16 - 3/16)	NO
	Overcasting stitch			Reinforcement of stretch fabric or decorative stitching	4.00 (3/16)	0.00 - 7.00 (0 - 1/4)	4.0 (3/16)	1.0 - 4.0 (1/16 - 3/16)	NO

INDEX

A

Accessories	
included accessories	4
options	8
Accessory case	4
Accessory compartment	4
Adjustments	
screen	329
Air vent	1
Alarm sounds	342
Aligning the position	206, 302
Alphabet characters	
character/decorative stitches	148
embroidery	190
embroidery edit	264
Alternate bobbin case	212
Appliqué	113
embroidery patterns	215
quilting	103
using a zigzag stitch	91
using an embroidery frame pattern	256
Array key	265, 271
Arrow keys	234, 269, 292, 317
Automatic fabric sensor system	73
Automatic reinforcement stitch key	69
Automatic thread cutting key	70
Automatic Threading button	3, 46

B

Back to beginning key	159
Ball point needle 75/107	58, 230
Bar tacks	129
Basting	87
Blind hem stitches	111
Block move key	319
Bobbin	
pulling up the bobbin thread	45
runs out of thread	223
setting	43
winding	37
Bobbin case	
alternate bobbin case (no color on the screw)	212
cleaning	326
Bobbin clip	5
Bobbin cover	2, 43
Bobbin holder (switch)	39
Bobbin winder	1
Border key	284, 289
Built-in camera	vi, 75, 138, 206, 302
Button sewing	131
4 hole buttons	132
shank	132
Buttonhole lever	2, 123, 128
Buttonholes	
four-step	125
odd-shaped/buttons that do not fit the button holder plate	124
one-step	121

C

Character spacing key	272
Character/Decorative Stitches	
adjustments	153
combining	162
editing	155
key functions	155
retrieving	176, 177
saving	171, 174, 175

selecting	146
sewing	152
stitch selection screens	147
Cleaning	
LCD screen	326
machine casing	326
race	326
Combining Patterns	
character/decorative stitches	162
embroidery edit	291
Cord guide bobbin cover	92
Crazy quilt	92
Custom Thread Table	279, 283
Cut/Tension key	227

D

Darning	127
Dart seam	88
Density key	239

E

Echo quilting	108
Edge sewing	
edge sewing using the built-in camera	vi, 138
Editing	
character/decorative stitches	155
embroidery	234
embroidery edit	267
MY CUSTOM STITCH	316
Elastic zigzag stitches	93
Elongation key	157
Embroidery	
adjusting the speed	231
automatic thread cutting function (END COLOR TRIM)	229
edges or corners	203
key functions	197
restarting from the beginning	225
resuming embroidery after turning off the power	225
ribbons or tape	203
selecting patterns	186
small fabrics	203
thread color display	231
thread trimming function (JUMP STITCH TRIM)	230
Embroidery card	194
Embroidery card reader	194
Embroidery edit	
changing the thread color	278
combined patterns	291, 294
custom thread table	279, 283
explanation of functions	262
key functions	268
repeated patterns	284
Embroidery foot "W"	183
Embroidery frame display	232
Embroidery frames	
attaching	204
inserting fabric	201
removing	205
types	200
using the embroidery sheet	202
Embroidery needle plate cover	213
Embroidery patterns	
aligning the position	302
checking the position	209
combining	291
duplicating	290
editing	267
linked characters	241

- pattern selection screens 187
 patterns which use appliqué 215
 retrieving 251, 252
 revising 234
 saving 246, 249, 250
 selecting 186, 263
 sewing 212
 using a frame pattern to make an appliqué 256, 257
 Embroidery positioning sticker 206, 302
 Embroidery sheet 202
 Embroidery unit 3, 184
 carriage 3
 carrying case 5
 Enlarger key 317
 Error messages 335
 Eyelet 133
- F**
- Fabrics
 fabric/thread/needle combinations 58
 sewing heavyweight fabrics 63
 sewing lightweight fabrics 64
 sewing stretch fabrics 65, 124
 Fagoting 117
 Feed dogs 2, 105
 Flat bed attachment 1, 184
 Flat fell Seam 89
 Foot controller 1, 61
 Forward/Back key 224, 225
 Free motion quilting
 free motion echo quilting foot "E" 108
 free motion open toe quilting foot "O" 107
 free motion quilting foot "C" 105
 Free motion sewing mode 105
- G**
- Gathering 88
 Grid direction key 317
- H**
- Handle 1
 Handwheel 1
 Heirloom 119
 Hemstitching
 daisy stitch 119
 drawn work 120
 Home page screen 14
- I**
- Image key 80, 160, 210, 318
 Insert key 320
- K**
- Key functions
 character/decorative stitches 155
 embroidery 197
 embroidery edit 268
 MY CUSTOM STITCH 316
 utility stitches 16
 Knee lifter 1, 71
- L**
- LCD screen 1, 14
 cleaning 326
 light 23
 locking 74
 Lower threading
 pulling up the bobbin thread 45
 setting the bobbin 43
 winding the bobbin 37
- M**
- Machine operation mode key 330
 Main power switch 1, 12
 Mirror image key 79, 158, 238
 Multi color key 240, 275
 Multi-directional sewing 134
 MY CUSTOM STITCH
 designing 314
 entering data 316
 key functions 316
 retrieving 323
 saving 322
 storing in your list 322
- N**
- Needle
 changing the needle 56
 changing the needle position 85
 checking the needle location vi, 75
 fabric/thread/needle combinations 58
 mode 14
 twin needle 49
 Needle bar thread guides 2, 50
 Needle clamp screw 2
 Needle mode selection key 49
 Needle plate 2
 Needle position 74, 85
 Needle Position button 3
- O**
- Operation buttons 1, 3
 Overcasting 91, 93, 94
- P**
- Patchwork 92
 Piecing 102
 Pintuck 90
 Pivoting 72
 Point delete key 318
 Power cord 13
 Power cord receptacle 1
 Presser foot
 attaching 54
 pressure 73
 removing 54
 types 347
 Presser foot code 15, 196
 Presser foot holder 2, 54
 Presser foot holder screw 2
 Presser foot lever 1, 63
 Presser Foot Lifter button 3
 Presser foot/Needle exchange key 50, 54, 55, 56, 183
 Pre-tension disk 1, 38, 41
 Print and stitch vii, 217, 306
- Q**
- Quilting 99
 free motion 105
 with satin stitches 104
- R**
- Race 326
 Repeated patterns 284
 Retrieving
 character/decorative stitch patterns 176
 computer 179, 254
 embroidery patterns 251

machine's memory 176, 251
 MY CUSTOM STITCH designs 323
 stitch settings 82
 USB media 177, 252
 utility stitches 82
 Reverse/Reinforcement Stitch button 3, 62, 69
 Reverse/Reinforcement stitches 62, 69
 Rotate key 237, 269

S

Satin stitches 104, 158
 Saving
 character/decorative stitches 171
 computer 175, 250
 embroidery patterns 246
 machine's memory 171, 246
 MY CUSTOM STITCH designs 322
 stitch settings 81
 USB media 174, 249
 utility stitches 81
 Scallop stitches 115
 Screen saver 25
 Set key 317
 Settings
 automatic reinforcement stitching 69
 automatic thread cutting 70, 229
 display language 29
 embroidery settings 24
 general settings 23
 machine setting mode key 22, 231, 279
 sewing settings 22
 stitch length 67
 stitch width 66
 thread tension 67, 227
 thread trimming 230
 Sewing key 290
 Sewing machine help key 32
 Sewing speed controller (speed control slide) 1, 3, 60
 Sewing type selection key 34
 Shelltuck stitches 114
 Side cutter 96
 Single/Repeat sewing key 158
 Single/Triple stitching key 318
 Size key 236, 270
 Size selection key 157
 Smocking stitches 116
 Soft cover case 8
 Speaker 23
 Specifications 343
 Spool cap 1
 Spool net 53
 Spool pin 1
 Spool stand 9, 41, 52
 Stabilizer 198
 Start/Stop button 3
 Starting point key 235
 Step stitch patterns 166
 Stitch setting chart 347
 Straight stitch foot 86
 Straight stitch needle plate 86
 Straight stitches 83
 Supplemental spool pin 1, 37, 50

T

Tape attaching 93
 Tape or elastic attaching 117
 Test key 318, 322
 Thread
 fabric/thread/needle combinations 58
 thread tension 67, 227
 Thread color display 231
 Thread cutter 1, 61
 Thread Cutter button 3

Thread density key 158
 Thread guide 1, 38, 40, 50
 Thread guide plate 1, 40, 46
 Thread marks 289
 Thread palette key 275, 278, 283
 Top cover 1
 Top stitching 116
 Touch pen 279, 317, 329
 holder 1
 Trial key 209
 Troubleshooting 330
 Twin needle 49

U

Uninterrupted embroidering 243
 Upgrading 344
 Upper threading
 twin needle mode 49
 using the "Automatic Threading" button 46
 using the spool net 53
 USB cable 19, 175, 220, 246, 250, 254, 309, 345
 USB media
 recalling 177, 252
 saving 174, 249
 usable 169, 244
 USB mouse 19, 25
 USB port connector
 for computer 1, 175, 250
 for media 1, 174, 249
 Utility stitches
 key functions 16
 pattern explanation key 35
 retrieving 82
 saving 81
 selecting 78
 sewing type selection key 34
 stitch selection screens 78
 stitch setting chart 347

V

Vertical stitch alignment foot "V" 139

W

Walking foot 55

Z

Zigzag stitches 91
 Zipper insertion
 centered 135
 side 136



Please visit us at <http://solutions.brother.com> where you can get product support and answers to frequently asked questions (FAQs).

